

VERSIA 2-AXIS SCAN HEAD

HIGH PERFORMING, FAST & EASY TO INTEGRATE SCAN HEAD FOR DEMANDING APPLICATIONS

Novanta develops photonics solutions through our globally recognized brands— ARGES, Cambridge Technology, Laser Quantum and Synrad— specializing in cutting-edge components and sub-systems for laser-based diagnostic, analytical, micromachining and fine material processing applications. Powerful lasers, coupled with advanced beam steering and intelligent sub-systems incorporating software and controls, deliver extreme precision and performance, tailored to our customers' demanding applications.

VERSATILE SOLUTION

Novanta's newest 2-axis hybrid scan head, VERSIA is designed with performance and system integration in mind. Built with a compact, industrial design ideal for versatile applications like micromachining and marking and coding. VERSIA features an IP54 rated enclosure, and intuitive, industry-standard input and outputs for easy integration. To enable users to monitor position feedback and other monitoring tools, VERSIA is engineered with bi-directional communication protocols. This is thanks to our brand-new digital servo design, which enables to carry multiple tunes and are individually optimized for specific applications. Users looking to upgrade their laser processing system can turn to VERSIA which features digital and analog electronics and serves as an intermediate option to a fully digital system.



Marking & Coding



Micromachining - OLED



OPTIMIZED SYSTEM PERFORMANCE

- Ability to carry multiple tunes where each tune is optimized for specific applications
- Dynamically matched mirror design improves system performance
- Bi-directional communication enables position feedback monitoring
- Achieve high performance thanks to integration of digital and analog electronics resulting in low drift and high repeatability
- Skywriting eliminates the processing time loss due to acceleration and deceleration times
- Integrated monolithic water-cooling design

EASY TO INTEGRATE AND IMPLEMENT

- Compact industrial design reduces system footprint, making it easy to integrate into existing systems
- Supports industry standard interface XY2-100 with a single DB25 connector as well as Novanta's NVL-100
- Integration flexibility with two orientation options for the DB25 interface on laser input side or the top side.
- Tested with other Novanta products for complete laser marking sub-system solution

VERSIA 2-AXIS SCAN HEAD

Specifications	14 mm
Mirror Aperture Size	14 mm
Scan Angle	±21°
Repeatability	<2 µrad
Long Term Offset Drift ⁴	<25 µrad
Long Term Scale Drift ⁴	<40 ppm
Temperature Offset Drift	<10 µrad/°C
Temperature Scale Drift	<10 ppm/°C
Wavelength Options ³ Max Power	CO ₂ : 9.2 - 10.6 µm 200 W Fiber: 1020 - 1090 nm 200 W Green: 513 - 534 nm check with factory UV: 341 - 357 nm check with factory
Command Resolution	16-bit for XY2-100 20-bit for NVL-100
Communication Interface	XY2-100 NVL-100
IP Rating	IP54
NVL-100	<150 ppm
Power Requirements	48V, 5A RMS
Operating Temperature	15 °C - 40 °C
Weight (approximate)	2.12 kg
Dimensions (L x W x H)	99 mm x 99 mm x 132.20 mm

Tune Specifications	
Step Response Time 1% of Full Scale ¹	400 µs
Max Speed	>80 rad/s
Tracking Error	<230 µs

Notes:

All angles are in optical degrees, unless otherwise noted. All specifications are subject to change without notice.

References:

1. Settling to within 1% of position. 2. With 160mm F-Theta lens. 3. Supports HeNe laser band. 4. During 8 hours of operation after 30 minutes of warm up, per axis.

VERSIA 2-AXIS SCAN HEAD

14 MM

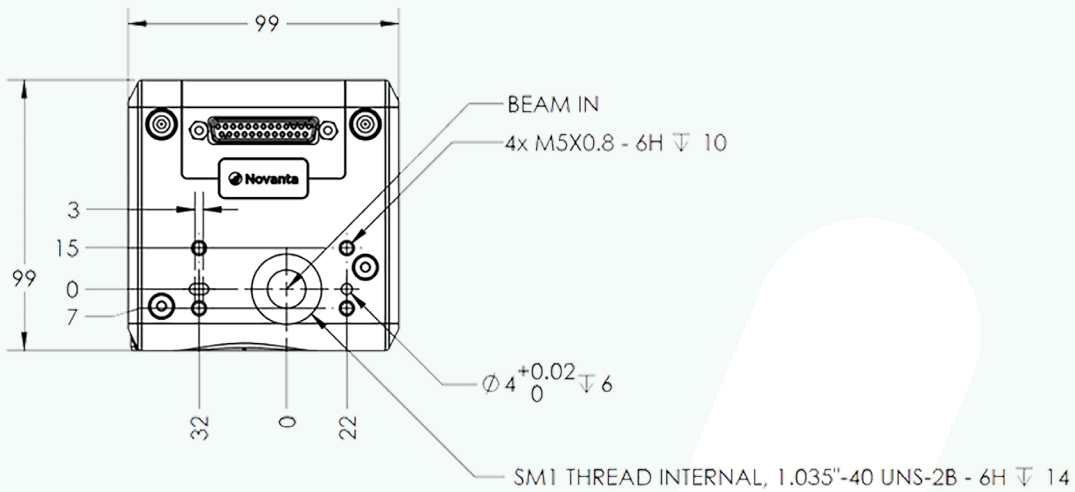
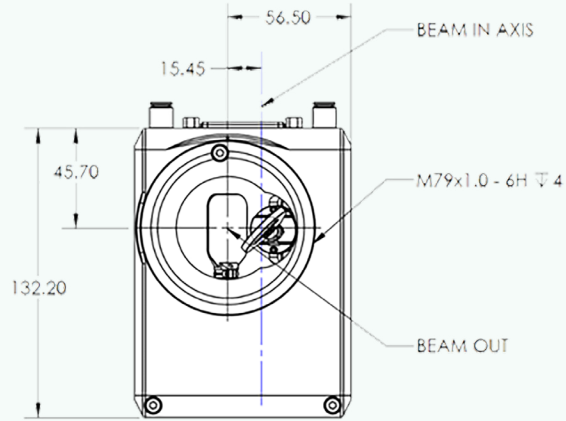
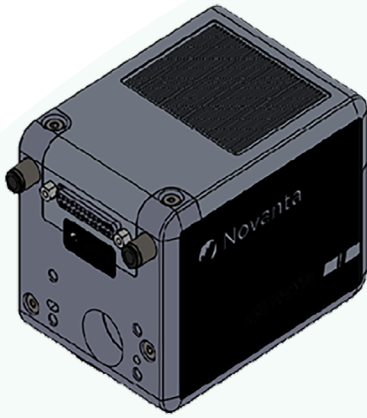

Notes:

All angles are in optical degrees, unless otherwise noted. Dimensions are in millimeters. All specifications are subject to change without notice.

CONTACT US

Americas, Asia Pacific

Novanta Headquarters
Bedford, USA
P +1-781-266-5700

Photonics@Novanta.com

Europe, Middle East, Africa

Novanta Europe GmbH
Wackersdorf, Germany
P +49 9431 7984-0

Milan, Italy
P +39-039-793-710

Photonics@Novanta.com

China

Novanta Sales & Service Office
Shenzhen, China
P +86-755-8280-5395

Suzhou, China
P +86-512-6283-7080

Photonics.China@Novanta.com

Japan

Novanta Service & Sales Office
Tokyo, Japan
P +81-3-5753-2460

Photonics.Japan@Novanta.com