

## ti SERIES CO<sub>2</sub> LASER DATA SHEET

# MORE AVERAGE POWER FOR HIGH-SPEED MARKING, CUTTING AND ADDITIVE MANUFACTURING

Industrial CO<sub>2</sub> lasers engineered for high performance with higher average power across 9.3 μm, 10.2 μm, and 10.6 μm wavelength options.

## FASTER PROCESSING SPEEDS, HIGHER RESOLUTION, AND COMPACT SIZE FOR OPTIMAL OEM INTEGRATION FLEXIBILITY

Maximum power and performance from an air-cooled CO<sub>2</sub> laser is the drive behind our ti Series technology. Using a patented hybrid-unstable resonator design creates a compact laser with excellent beam quality focused to the smallest achievable spot size, delivering the maximum power density on a work surface. The high performance RF circuitry designed specifically to match its compact resonator delivers fast rise times with outstanding square-wave performance. High power, fast pulsing capabilities, and exceptional optical quality are ideally suited for applications where rapid scanning or pulsing of the laser beam is required.



## HIGH STABILITY (HS) MODELS

- Available in 60, 80 and 100 Watt models
- Well suited for selective laser sintering (SLS) or various polymers
- Excellent power stability, better than ±2%
- Compact footprint and common beam exit across all power levels maximizes OEM integration flexibility



Unique 100 Watt fan cooled model offers an economical option for OEMs and system architects



## DESIGNED FOR OEMs AND SYSTEM ARCHITECTS

### Faster throughput

- Higher than average power rating across 9.3 μm, 10.2 μm, and 10.6 μm wavelength options
- Efficient laser energy delivery with fast rise/fall times

### Adds flexibility to OEM machine design

- Similar compact footprint across 60, 80, and 100 Watt models
- Consistent beam exit height across all ti Series lasers makes power upgrades easier
- Choose the most effective and economical cooling option; available in fan or water-cooled models
- Expands laser processing capability with multiple wavelength options

### Pulse Model For Heat-Sensitive Materials

- 100 Watts average power and more than 300 Watts peak power
- Broad material processing capability with 9.3 μm, 10.2 μm, and 10.6 μm wavelength options
- Minimizes Heat Affected Zone (HAZ) with < 60 μs pulse rise times
- Cuts polymer films with a crisp edges and minimal lip melt, essential for modern electronics manufacturing

## ti SERIES CO<sub>2</sub> LASER RECOMMENDED APPLICATIONS



60, 80, and 100 W of power and fast rise/fall times ensures clean, crisp cutting. Multiple wavelength options enables cutting across a wide range of materials.



Easily applies permanent alpha numeric codes, bar codes, text, and expiration dates to a variety of packaging materials that will not smear or rub off



The high peak power is essential to minimizing heat build-up and avoid cracking when processing brittle materials such as alumina, ceramic and quartz glass. Excellent beam quality allows for very small features and clean symmetric holes.

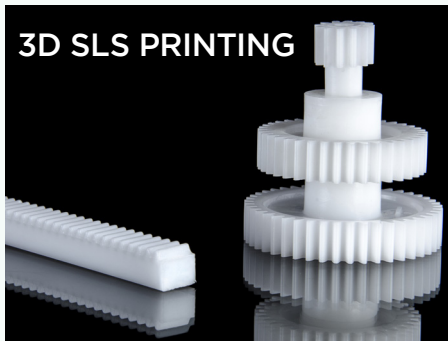

Excellent power density stability and a range of power levels make the ti Series High Stability CO<sub>2</sub> lasers the best choice for 3D printing equipment OEMs.

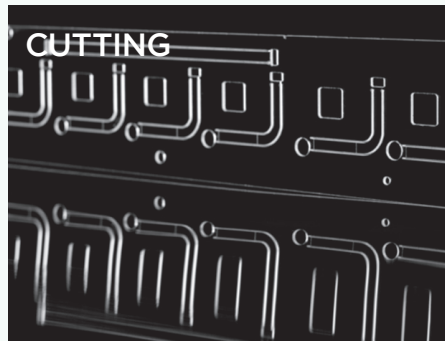

Precise cutting and engraving applications benefit from the ti Series High Stability CO<sub>2</sub> lasers, delivering excellent detail and clean cut edges.



High power density stability and fast rise/fall times makes the ti Series High Stability lasers an excellent choice for sensitive marking applications, like denim.



High peak power delivers smooth, clean cuts with minimal charring or discoloration. Extremely effective for high fashion textile applications.

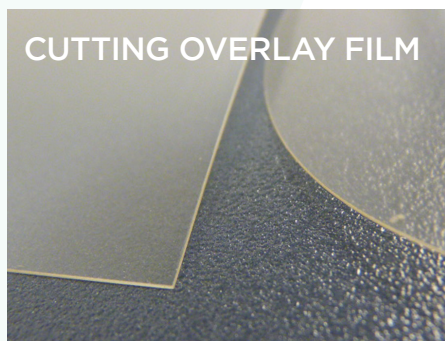

Multiple wavelength options and excellent peak power to cut polymer films with crisp edges and minimal lip melt, essential for modern electronics manufacturing.

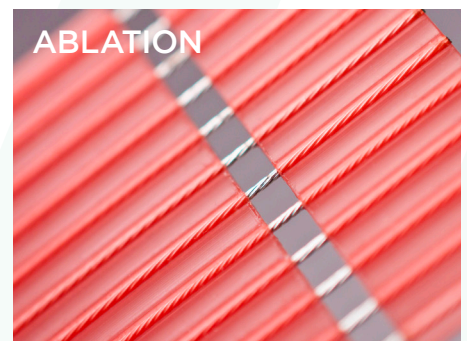

Optimized wavelengths and excellent power stability allow precise removal of insulation and coatings without damaging the underlying materials.

## ti SERIES CO<sub>2</sub> LASER SPECIFICATIONS

Output Specifications	ti60	ti80	ti100
Wavelength	9.3 μm, 10.2 μm, 10.6 μm		
Average Output Power <sup>1</sup>	> 60 W	> 80 W	> 100 W
Power Stability (cold start) <sup>2</sup>	± 7%		
Power Stability (typical, after 3 min.)	± 6%		
Beam Quality (M <sup>2</sup> )	< 1.2		
Beam Diameter <sup>3</sup>	2.0 mm ± 0.3 mm		
Divergence (full angle)	< 7.0 mrad		
Ellipticity	< 1.2		
Polarization	Linear (Vertical)		
Rise Time	< 75 μs		
Operating Frequency	0 - 160 kHz		
<b>Power Supply</b>			
DC Voltage Input	48 VDC		
Maximum Current	18.0 A	22.0 A	35.0 A
<b>Cooling</b>			
Maximum Heat Load	900 W	1200 W	1700 W
Coolant Temperature	< 40° C (air) 18 - 22° C (water)		Guaranteed with fan shroud (air) < 40° C (air) 18 - 22° C (water)
Minimum Flow Rate	140 CFM, 2 required (air) 1.0 GPM, < 60 PSI (water)	190 CFM, 2 required (air) 1.0 GPM, < 60 PSI (water)	1.0 GPM, < 60 PSI (water)
<b>Environmental</b>			
Operating Ambient Temperatures	15 - 40° C		
Maximum Humidity	95%, non-condensing		
<b>Physical</b>			
OEM Air (LxWxH) mm (inches)	571 x 158 x 148 (22.5 x 6.2 x 5.8)		n/a
Fan (LxWxH) mm (inches)	571 x 196 x 150 (22.5 x 7.7 x 5.9)		571 x 196 x 150 (22.5 x 7.7 x 5.9)
Water (LxWxH) mm (inches)	584 x 143 x 150 (23 x 5.6 x 5.9)		584 x 143 x 150 (23 x 5.6 x 5.9)
OEM Air Weight kg (lbs.)	11.6 (25.5)		n/a
Fan Weight kg (lbs.)	13.1 (28.9)		14.6 (32.1)
Water Weight kg (lbs.)	11.9 (26.2)		11.9 (26.2)

1 - Power level guaranteed for 2 years from date of shipment, regardless of operating hours, within recommended coolant flow rate and temperature range.

2 - Measured from cold start as  $\pm(P_{\max} - P_{\min}) / (P_{\max} + P_{\min})$

3 - Measured 1/e<sup>2</sup> diameter at laser output.

Please see the manual for the full list of specifications and associated measurement conditions

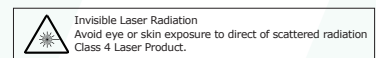

## ti SERIES HIGH STABILITY CO<sub>2</sub> LASER SPECIFICATIONS

Output Specifications	ti60-HS	ti80-HS	ti100-HS
Wavelength	10.6 μm		
Average Output Power <sup>1</sup>	> 60 W	> 80 W	> 100 W
Power Stability (cold start) <sup>2</sup>	± 4%		
Power Stability (typical, after 3 min.)	± 2%		
Beam Quality (M <sup>2</sup> )	< 1.2		
Beam Diameter <sup>3</sup>	2.0 mm ± 0.3 mm		
Divergence (full angle)	< 7.0 mrad		
Ellipticity	< 1.2		
Polarization	Linear (Vertical)		
Rise Time	< 75 μs		
Operating Frequency	0 - 160 kHz		
<b>Power Supply</b>			
DC Voltage Input	48 VDC		
Maximum Current	18.0 A	22.0 A	35.0 A
<b>Cooling</b>			
Maximum Heat Load	900 W	1200 W	1700 W
Coolant Temperature	18 - 22° C (water)		
Minimum Flow Rate	1.0 GPM, < 60 PSI (water)		
<b>Environmental</b>			
Operating Ambient Temperatures	15 - 40° C		
Maximum Humidity	95%, non-condensing		
<b>Physical</b>			
LxWxH mm (inches)	544 x 104 x 150 (21.4 x 4.1 x 5.9)		
Water Weight kg (lbs.)	19.0 (42.0)		

1 - Power level guaranteed for 2 years from date of shipment, regardless of operating hours, within recommended coolant flow rate and temperature range.

2 - Measured from cold start as  $\pm(P_{\max} - P_{\min}) / (P_{\max} + P_{\min})$

3 - Measured 1/e<sup>2</sup> diameter at laser output.

Please see the manual for the full list of specifications and associated measurement conditions

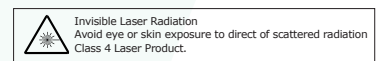

## ti SERIES PULSED CO<sub>2</sub> LASER SPECIFICATIONS

Output Specifications	ti100P
Wavelength	9.3 μm, 10.2 μm, 10.6 μm
Average Output Power <sup>1</sup>	> 100 W
Peal Pulse Power (typical) <sup>2</sup>	> 300 W
Peak Pulse Energy (maximum) <sup>3</sup>	130 mJ
Power Stability (cold start) <sup>4</sup>	± 7%
Power Stability (typical, after 3 min.)	± 3%
Beam Quality (M <sup>2</sup> )	< 1.2
Beam Diameter <sup>5</sup> (with 3X expander)	6.5 mm ± 2.0 mm
Divergence (full angle with 3X expander)	2.2 mrad ± 0.5 mrad
Ellipticity	< 1.2
Polarization	Linear (Vertical)
Rise / Fall Time <sup>6</sup>	< 60 μs/ < 100 μs
Operating Frequency	0 - 100 kHz
Duty Cycle Range	< 50%
Maximum Pulse Length	500 μs
Power Supply	
DC Voltage Input	48 VDC
Maximum Current	60 A
Pulsed Current	100 A for < 500 μs
Cooling	
Maximum Heat Load	1700 W
Coolant Temperature	18 - 22° C (water)
Minimum Flow Rate	2.0 GPM, < 60 PSI (water)
Environmental	
Operating Ambient Temperatures	15 - 40° C
Maximum Humidity	95%, non-condensing
Physical	
LxWxH mm (inches)	633 x 142 x 150 (24.9 x 5.6 x 5.9)
Water Weight kg (lbs.)	12.1 (26.7)

1 - Power level guaranteed for 2 years from date of shipment, regardless of operation hours, within recommended coolant flow rate and temperature range

2 - Measured at 1 kHz, 10% duty cycle.

3 - Measured from average power at 100 Hz, 5% duty cycle.

4 - Measured as  $\pm(P_{max} - P_{min}) / (P_{max} + P_{min})$  from cold start at 5 kHz, 50% duty cycle

5 - Measured 1/e<sup>2</sup> diameter at output of 3X beam expander. The ti100P is shipped with a beam expander mounted and aligned to the faceplate. Available expansion ratios are 3X, 4X, and 5X.

6 - Measured at 100 Hz, 5% duty cycle. Please see the manual for the full list of specifications and associated measurement conditions.

Please see the manual for the full list of specifications and associated measurement conditions

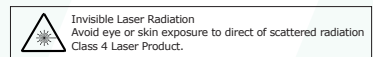

# ti SERIES TECHNICAL ILLUSTRATIONS

Dimensions are in mm (inches)

## AIR-COOLED

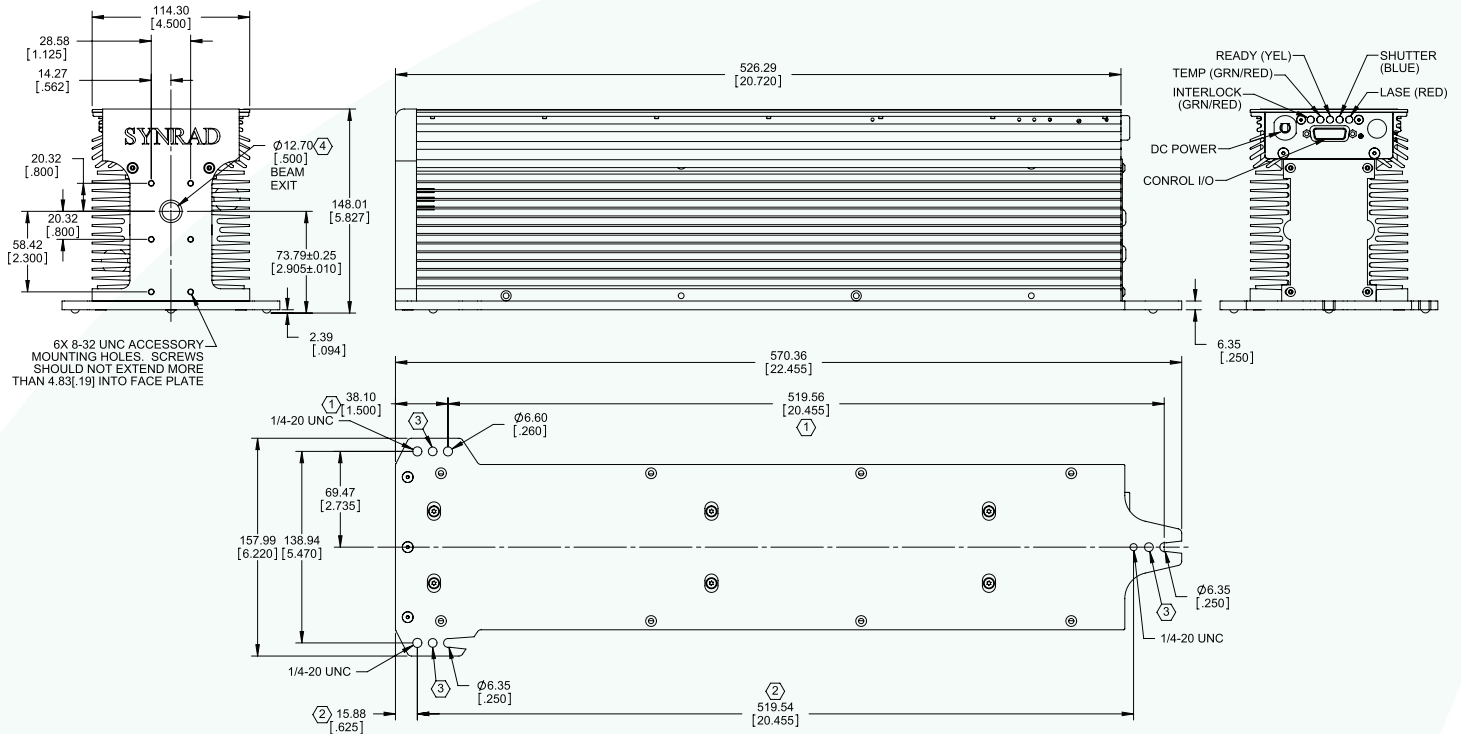

NOTES:

- ① THIS MOUNTING HOLE PATTERN USED WHEN TOP ACCESS FASTENING DESIRED.
- ② THIS MOUNTING HOLE PATTERN USED WHEN BOTTOM ACCESS FASTENING DESIRED.
- ③ HARDENED BALL MOUNTING POINT, 3X (Ø.250 STEEL BALL).
- ④ BEAM PATH MAY NOT BE CENTERED OR PERPENDICULAR TO FACEPLATE APERTURE.

## WATER-COOLED & HIGH STABILITY

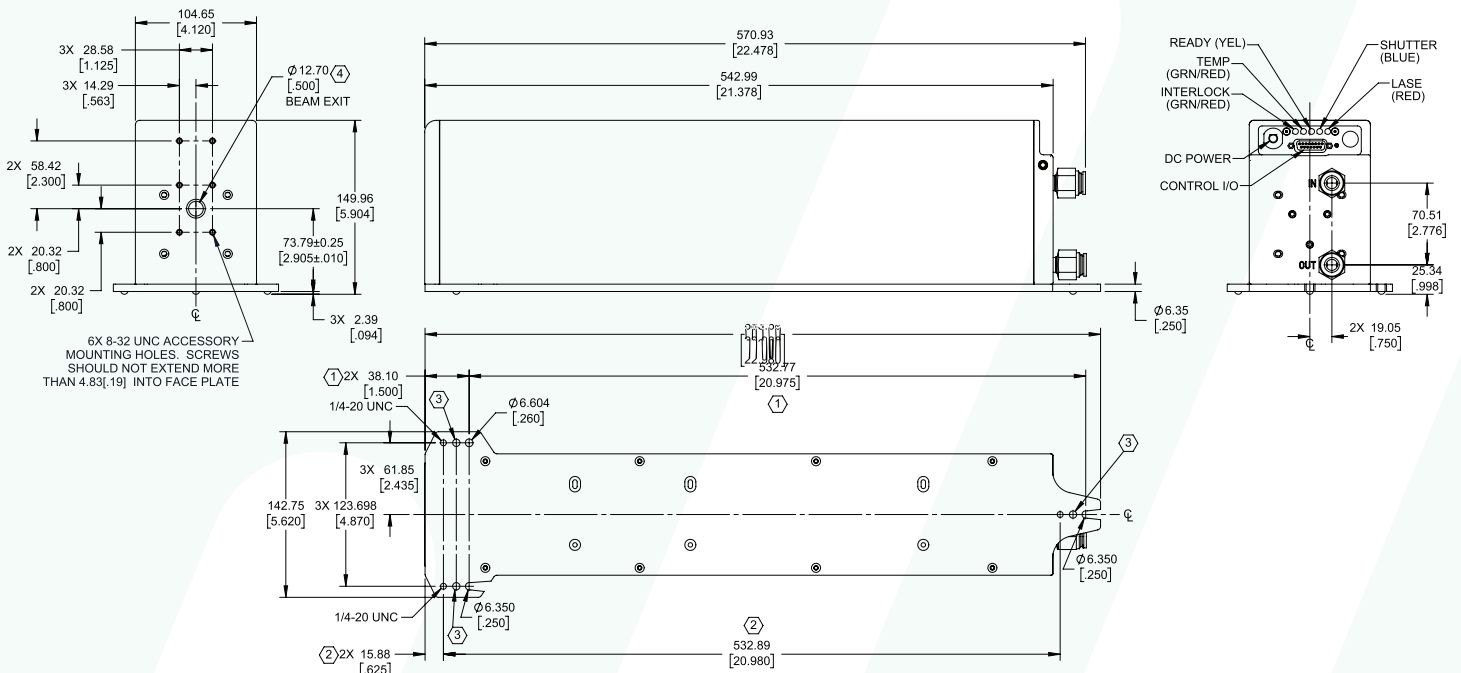

NOTES:

- ① THIS HOLE PATTERN USED WHEN TOP ACCESS FASTENING DESIRED.
- ② THIS HOLE PATTERN USED WHEN BOTTOM ACCESS FASTENING DESIRED.
- ③ HARDENED BALL MOUNTING POINT (Ø.250 STEEL BALL).
- ④ BEAM PATH MAY NOT BE CENTERED OR PERPENDICULAR TO FACEPLATE APERTURE.

# ti SERIES TECHNICAL ILLUSTRATIONS

Dimensions are in mm (inches)

## ti100 FAN COOLED

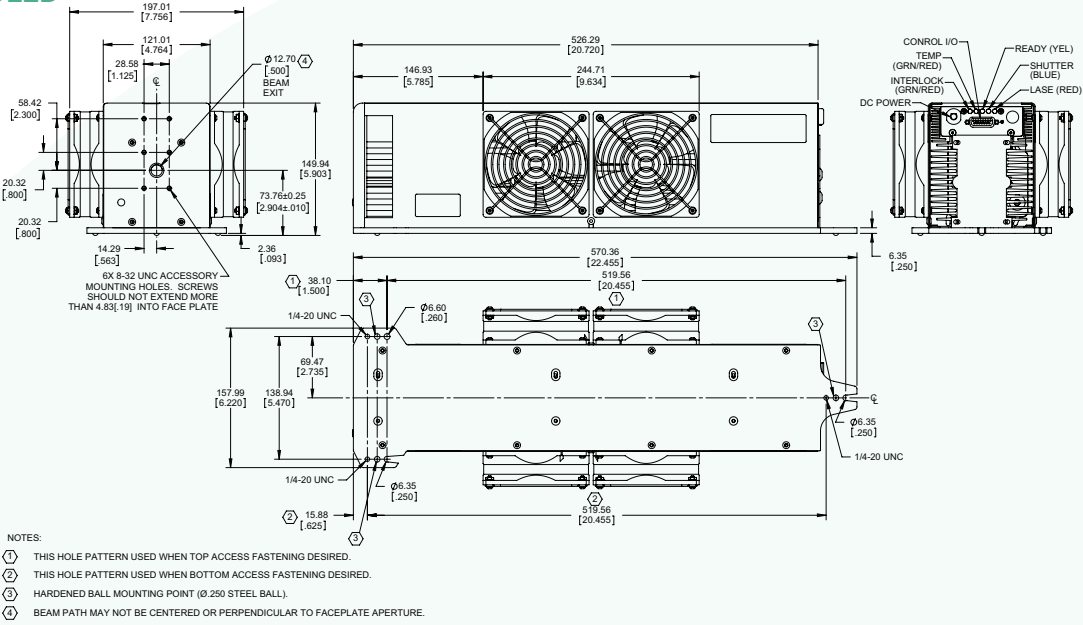

## ti 100P PULSED CO<sub>2</sub> LASER

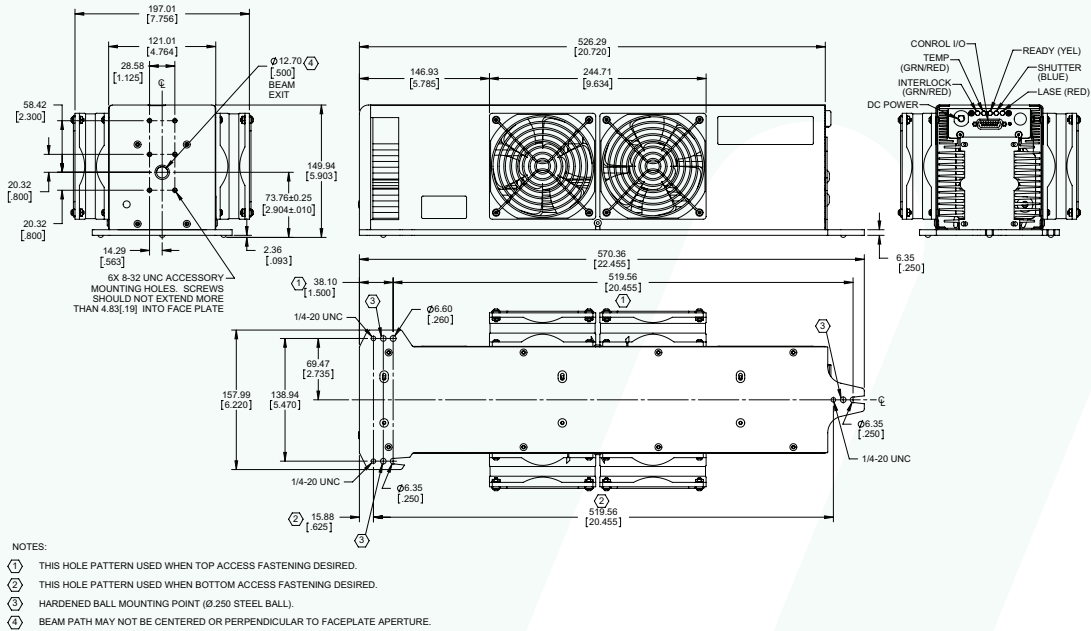

## CONTACT US

### Americas, Asia Pacific

Novanta Headquarters  
Bedford, USA  
P +1-781-266-5700

Photonics@Novanta.com

### Europe, Middle East, Africa

Novanta Europe GmbH  
Wackersdorf, Germany  
P +49 9431 7984-0

Milan, Italy  
P +39-039-793-710

Photonics@Novanta.com

### China

Novanta Sales & Service Office  
Shenzhen, China  
P +86-755-8280-5395

Suzhou, China  
P +86-512-6283-7080

Photonics.China@Novanta.com

### Japan

Novanta Service & Sales Office  
Tokyo, Japan  
P +81-3-5753-2460

Photonics.Japan@Novanta.com