

Tara Stereo Vision USB 3.0 Camera

Datasheet



Version 1.4

e-con Systems

8/29/2017



e-con Systems

Your Product Development Partner

Disclaimer

The specifications and features of Tara - Stereo camera board are provided here as reference only and e-con Systems reserves the right to edit/modify this document without any prior intimation of whatsoever.

Contents

INTRODUCTION TO TARA - SEE3CAM STEREO	4
1 DESCRIPTION	5
1.1 GLOBAL SHUTTER CMOS SENSOR.....	7
1.2 TARA BOARD OVERVIEW	7
2 FEATURES	7
KEY SPECIFICATIONS	9
3 SPECIFICATIONS.....	9
3.1 MAXIMUM FRAME RATE SUPPORTED	9
3.2 CMOS IMAGE SENSOR SPECIFICATION.....	9
PIN NUMBERS.....	11
4 GENERAL PURPOSE PIN DESCRIPTION	11
5 USB 3.0 MICRO-B PIN DESCRIPTION	12
CONNECTOR PART NUMBERS.....	13
ELECTRICAL SPECIFICATION	14
6 RECOMMENDED OPERATING CONDITION	14
6.1 Y16 WITH USB 3.0	14
6.2 RGB24 WITH USB 3.0	14
6.3 Y16 WITH USB 2.0	14
6.4 RGB24 WITH USB 2.0	15
7 DC CHARACTERISTICS	15
7.1 ABSOLUTE MAXIMUM FOR GPIO PINS	15
7.2 EXPOSURE VOLTAGE LEVELS (CN3 CONNECTOR)	15
7.3 LED_OUT VOLTAGE LEVELS (CN3 CONNECTOR)	16
8 OPERATING TEMPERATURE RANGE	16
MECHANICAL SPECIFICATIONS	17
9 TARA DIMENSION.....	17
10 LENS HOLDER DIMENSIONS	17
SUPPORT	19

REVISION HISTORY 20

Introduction to Tara - See3CAM_Stereo

The Tara - See3CAM_Stereo, hereafter called as Tara is a UVC compliant USB 3.0 SuperSpeed Stereo vision camera from e-con Systems, a leading embedded Product Design Services company which specializes in the advanced camera solutions. Tara is based on MT9V024 stereo sensor from OnSemi imaging which supports WVGA (752 x 480) at 60fps over USB 3.0 in uncompressed format. Tara is the latest member of the See3CAM family of USB 3.0 SuperSpeed camera products launched by e-con Systems.

Tara is a monochrome camera with the S-mount (also known as M12 board lens) lens holder. The S-mount is one of the most commonly used small form-factor lens mounts for board cameras. Tara has two OnSemi's 1/3-inch MT9V024 image sensors separated by an inter-ocular distance or base line of 60 mm.

Tara is UVC-compliant camera and it does not require any drivers to be installed on the PC. The native UVC drivers of Windows and Linux Operating Systems will be compatible with this camera. e-con Systems provides the sample application that demonstrates some of the features of this camera.

Currently Tara saves the images in the following formats:

- Y16 format (8bpp).
- RGB24 formats (10bpp).

The resolutions supported in these two formats are:

- 752 x 480 (752 x 480 from each sensor) at 60 fps in USB 3.0 and 30 fps in USB 2.0.
- 640 x 480 (640 x 480 from each sensor) at 60 fps in USB 3.0 and 30 fps in USB 2.0.
- 320 x 240 (320 x 240 (binned from 640 x 480) from each sensor) at 60 fps in USB 3.0 and USB 2.0.

The Field of View (FOV) crop details for each resolutions of Tara are shown in the below table.

Table 1: Resolution, Frame Rates and Crop Details of Tara

Format	Resolution	Frame Rate (FPS)		% Crop in FOV	
		USB 3.0	USB 2.0	Horizontal	Vertical
Y16 (8 bit RAW)	320 x 240	60	60	14.89%	0%
	640 x 480	30 and 60	30	14.89%	0%
	752 x 480	30 and 60	30	0%	0%
RGB24 (10 bit RAW)	320 x 240	60	60	14.89%	0%
	640 x 480	30 and 60	30	14.89%	0%
	752 x 480	30 and 60	30	0%	0%

This document describes the features of Tara and the pin-outs of the connectors including with mechanical diagram.

1 Description

Tara is a Stereo Vision Camera, that uses two 1/3-inch OnSemi's MT9V024 image sensors. The form factor of the camera is 95mm x 17mm without enclosure. Tara is a USB 3.0 camera capable of streaming camera frames in WVGA resolution at 60 fps when connected to USB 3.0 host port by leveraging the full throughput of USB3.0. Other resolutions supported are VGA (cropped) at 60 fps and QVGA at 60 fps. The base line of this stereo camera is 60mm.

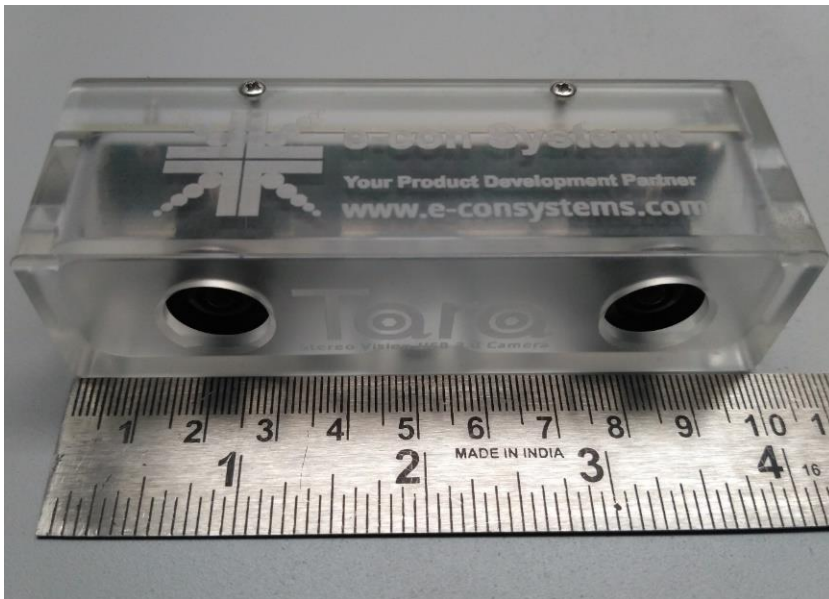

Figure 1: Tara Form Factor

This camera is provided with a 6-axis Inertial Measurement Unit (IMU), which comprises a 3D accelerometer and a 3D gyroscope. The accelerometer in the IMU is useful for measuring the linear accelerations and the gyroscope helps in measuring the angular accelerations.



Figure 2: Tara Front View

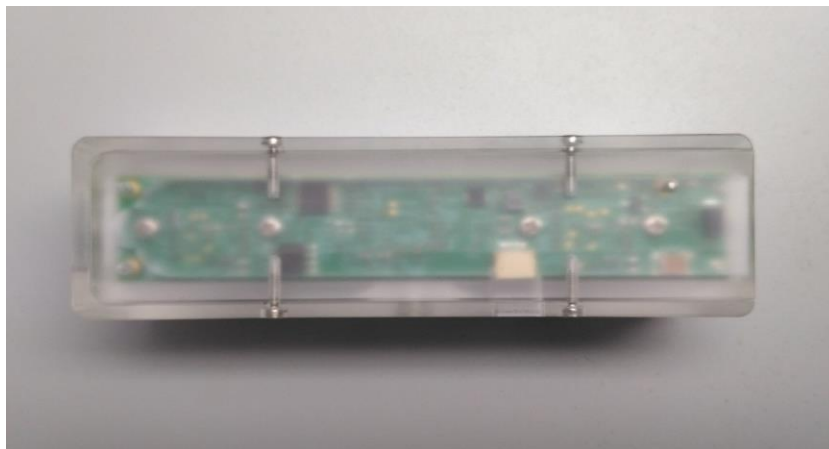

Figure 3: Tara Back View

This UVC compliant Tara - Stereo Vision Camera supports WVGA (752 x 480p) at 60 fps, VGA (cropped) (640 x 480) at 60 fps and QVGA (320 x 240) at 60 fps over USB 3.0. So, video streaming through UVC is possible without any special drivers on Operating Systems which has built-in support for UVC standards. For example, Tara does not require any device drivers to be installed on Windows 7 (both regular PC versions and the embedded versions) as these Operating Systems is provided with the Microsoft supplied UVC drivers. From Windows XP (with Service Pack2), all the Windows Operating Systems have built in support for UVC drivers and Tara works seamlessly with these Operating Systems. The camera is exposed as DirectShow Capture source to the Windows PC and e-con provides sample DirectShow application that demonstrates the features of this camera. Any DirectShow compliant application such as Skype can work with this camera as webcam.

e-con Systems also provides the OpenCV libraries and sample applications for Tara. Some of the sample applications include 3D depth measurements and point cloud application. The sample application software can be used as a reference for building customized stereo camera applications.

The hardware of Tara is explained in detail below.

1.1 Global Shutter CMOS Sensor

Tara uses OnSemi MT9V024 image sensor. The MT9V024 is a 1/3-inch wide-VGA resolution CMOS active-pixel digital image sensor. The sensor is provided with TrueSNAP™ global shutter and high dynamic range (HDR) operation. This wide VGA CMOS image sensor features OnSemi's breakthrough low-noise CMOS imaging technology that achieves CCD image quality (based on signal-to-noise ratio and low-light sensitivity) while maintaining the inherent size, cost and integration advantages of CMOS.

The MT9V024 sensor can be operated in its default mode or be programmed for frame size, exposure, gain setting, and other parameters. The default mode outputs a wide-VGA-size image at 60fps.

In Tara, the two MT9V024 sensors are configured as master-slave sensor pair to operate in synchronous parallel stereoscopic mode. Tara configures the MT9V024 sensors in Synchronous Stereo mode and combines the two stereo videos and streams to the CPU.

1.2 Tara Board Overview

The Tara - Stereo Vision Camera comprises two OnSemi's MT9V024 global shutter WVGA CMOS camera sensors, physically separated by 60mm (baseline). The Tara - Stereo Vision Camera has the necessary circuitry to make the two global shutter sensors function in lockstep mode and thereby making them to deliver synchronous parallel stereoscopic video frame at three different resolutions. The synchronous video frames output by both the sensors are logically combined and presented as a single video frame by the e-con System's stereo camera. Based on the application's request these synchronous left and right camera video frames can be presented as separate frame buffers or a common frame buffer.

The Stereo camera uses S-mount lens holders and any compatible M12 lenses can be used on the camera. Any change in the lens or lens position will certainly require lens calibration to be done and e-con has provided lens calibration software with a 'how-to' article explaining the lens calibration process in detail.

2 Features

The features of Tara are as follows:

- 1/3" OnSemi's MT9V024 Global Shutter Monochrome CMOS image sensors.
- WVGA (752 x 480p) at 60 fps, VGA (cropped) (640 x 480) at 60 fps and QVGA (320 x 240) at 60 fps over USB 3.0.
- Pixel synchronous parallel monochrome output.
- USB powered, and no separate power required.
- Base line distance of 60 mm.
- Comes with M12 S-mount lens holder.

- Provided with pre-calibrated S-mount lens pair.
- OpenCV sample applications.
- Point cloud application support.

The FOV of Tara is shown below.

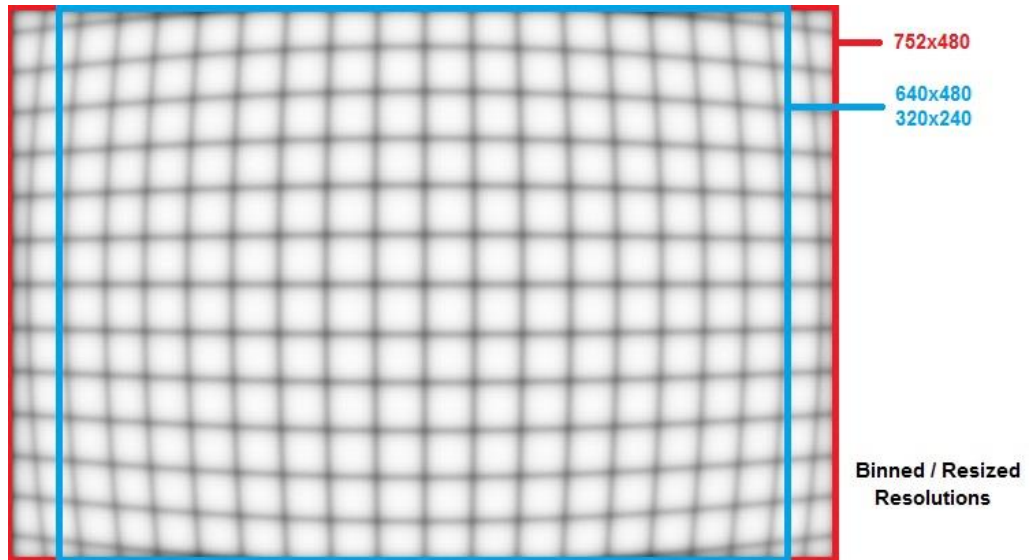

Figure 4: FOV of Tara

Key Specifications

This section describes the key specifications of Tara.

3 Specifications

The below table describes the specification of Tara.

Table 2: Tara Specifications

Description	Specification
Size (L X W X H) in mm	100 x 30 x 35 (With Enclosure)
	95 x 17 x 27 (Without Enclosure)
Weight (Without USB Cable)	80.5 Grams (With Enclosure)
	28.5 Grams (Without Enclosure)
Output Format	8-bit/10-bit Monochrome
Supported Resolutions	WVGA (752 x 480p), VGA (640 x 480) and QVGA (320 x 240)
Supported OS	Windows7, 8.1 and 10, Ubuntu 12.04 and 16.04 (both 32bit and 64bit)
USB Version	3.0 and 2.0
USB Video Class Version	UVC Version 1.0
Product ID (PID)	0 x C114
Vendor ID (VID)	0 x 2560

3.1 Maximum Frame Rate Supported

The below table describes the maximum frame rate supported by Tara.

Table 3: Frame Rate Supported

Format	Resolution	Frame Rate (FPS)	
		USB 3.0	USB 2.0
Y16 (8 bit RAW)	320 x 240	60	60
	640 x 480	30 and 60	30
	752 x 480	30 and 60	30
RGB24 (10 bit RAW)	320 x 240	60	60
	640 x 480	30 and 60	30
	752 x 480	30 and 60	30

3.2 CMOS Image Sensor Specification

The below table describes the specifications of CMOS Image sensor used in this Tara camera board. For more information about the MT9V024 sensor or for datasheet, please contact On Semiconductor.

Table 4: CMOS Image Sensor Specification

Sensor Specification	
Type / Optical Size	1/3" Optical format CMOS Image sensor

Resolution	WVGA
Sensor Type	10-bit Monochrome
Pixel Size	6.0 μm x 6.0 μm
Sensor Active Area	752 x 480
Responsivity	4.8 V/lux-sec (550 nm)
SNR	NA
Dynamic Range	>55dB in linear and >100dB in HDR mode

Pin Numbers

The Tara board has two connectors namely USB 3.0 connectors and one GPIO Header. The pin descriptions are explained as follows.

4 General Purpose Pin Description

The general-purpose header has 4 pins for controlling the exposure. The pin description of GPIO header is shown below.

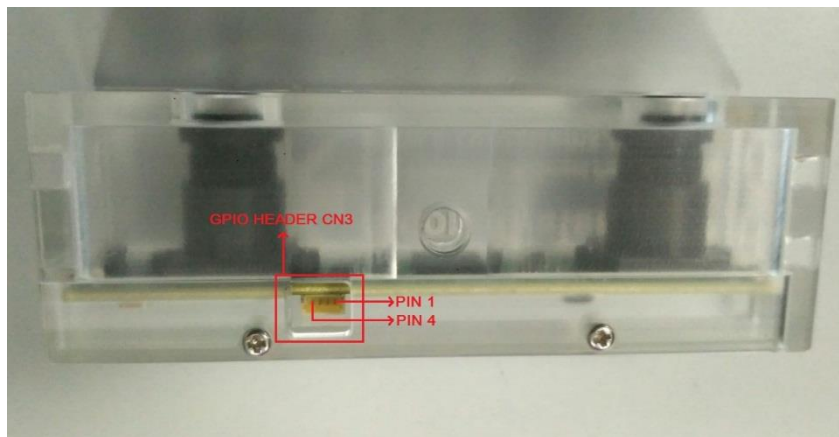

Figure 5: GPIO Header of Tara

The below table describes the pin outs of the GPIO header.

Table 5: Pin Types and Description

CN3 Pin No	Signal Name	Pin Type	Description
1	VCC	Power	Supplies 5V Power from the board
2	Exposure input	Input	Controls exposure of both the sensors
3	LED_OUT	Output	LED_OUT signal from sensor
4	GND	Power	Ground

5 USB 3.0 Micro-B Pin Description

The below table describes the pin-outs of USB 3.0 connector which is used to connect Tara with PC through USB 3.0 Cable. This is a standard USB 3.0 Micro-B connector.

Table 6: Pin Types and Description

CN1 Pin No	Signal Name	Pin Type	Description
1	VCC	Power	Supplies 5V Power to the board
2	D-	I/O	USB Data-
3	D+	I/O	USB Data+
4	OTG ID	-	OTG ID for Identifying lines
5	GND	Power	Ground
6	SSTX-	Output	SuperSpeed Transmit Data -
7	SSTX+	Output	SuperSpeed Transmit Data +
8	GND	Power	Ground
9	SSRX-	Input	SuperSpeed Receive Data -
10	SSRX+	Input	SuperSpeed Receive Data +

Connector Part Numbers

The USB 3.0 connector is the standard Micro-B connector as specified in the USB 3.0 standards. Any USB 3.0 standard compliant USB 3.0 cable will be compatible with this connector. The below table describes the connectors used in Tara.

Table 7: Connectors and its Part Number Details

Connector	Description	Manufacturer	Part Number
Exposure Header (CN3)	CONN HEADER SH 4POS SIDE 1MM TIN	JST Sales America Inc	SM04B-SRSS- TB(LF)(SN)

Electrical Specification

This section lists down the electrical specification and recommended operating conditions of Tara.

6 Recommended Operating Condition

The below table describes the recommended operation condition of Tara.

Table 8: Recommended Operation Condition for Tara

Parameter	Typical Operating Voltage	Typical Power consumption (W)
USB input voltage	5V \pm 250Mv	2.27

6.1 Y16 with USB 3.0

The below table lists down the current consumed by Tara in Y16 format with USB 3.0 under various operating conditions.

Table 9: Y16 with USB 3.0

S. No	Resolution	Frame Rate (FPS)	Supply Voltage (V)	Typical Current (mA)	Power Consumption (W)
1	320 x 240	60	5	195	0.975
2	640 x 480	30	5	200	1
		60	5	225	1.125
3	752 x 480	30	5	202	1.01
		60	5	228	1.14

6.2 RGB24 with USB 3.0

The below table lists down the current consumed by Tara in RGB24 format with USB 3.0 under various operating conditions.

Table 10: RGB24 with USB 3.0

S. No	Resolution	Frame Rate (FPS)	Supply Voltage (V)	Typical Current (mA)	Power Consumption (W)
1	320 x 240	60	5	196	0.98
2	640 x 480	30	5	200	1
		60	5	226	1.13
3	752 x 480	30	5	203	1.015
		60	5	231	1.155

6.3 Y16 with USB 2.0

The below table lists down the current consumed by Tara in Y16 format with USB 2.0 under various operating conditions.

Table 11: Y16 with USB 2.0

S. No	Resolution	Frame Rate (FPS)	Supply Voltage (V)	Typical Current (mA)	Power Consumption (W)
1	320 x 240	60	5	154	0.77
2	640 x 480	30	5	162	0.81
3	752 x 480	30	5	164	0.82

6.4 RGB24 with USB 2.0

The below table lists down the current consumed by Tara in RGB24 format with USB 2.0 under various operating conditions.

Table 12: RGB24 with USB2.0

S. No	Resolution	Frame Rate (FPS)	Supply Voltage (V)	Typical Current (mA)	Power Consumption (W)
1	320 x 240	60	5	156	0.78
2	640 x 480	30	5	166	0.83
3	752 x 480	30	5	169	0.845

Note: These values are measured in our lab and this can be used as reference only. The current measurements are typical values and are subject to change for different camera boards under different conditions. However, these values can be taken as a reference for power estimation and power supply design.

7 DC Characteristics

The DC Characteristics of Tara is listed as follows.

7.1 Absolute Maximum for GPIO Pins

The below table describes the maximum input voltage for GPIO pins.

Table 13: Absolute Maximum Input Voltage for GPIO Pins

Parameter	Description	Value	Units
Vinput ¹	DC Input voltage to any input pin	3.3	V

¹ Exceeding the maximum value may shorten the life of the device or cause permanent damage to the device

7.2 Exposure Voltage Levels (CN3 Connector)

The below table describes the exposure voltage levels of CN3 connector.

Table 14: Exposure Voltage Levels

Symbol	Parameter	Min	Typical	Max	Unit
Digital Input signals					
V _{IL}	Input voltage LOW			0.8	V
V _{IH}	Input voltage HIGH	2			V

7.3 LED_OUT Voltage Levels (CN3 Connector)

The below table describes the LED_OUT Voltage levels of CN3 connector.

Table 15: LED_OUT Voltage Levels

Symbol	Parameter	Min	Typical	Max	Unit
Digital Input signals					
V _{OL}	Output voltage LOW			0.3	V
V _{OH}	Output voltage HIGH	3			V

8 Operating Temperature Range

The below table describes the operating temperature range of Tara.

Table 16: Operating Temperature Range

Parameter Description	Temperature Range
Operating temperature range ²	-30°C to 70°C

²This is the maximum temperature range up to which the camera sensor⁴ can be operated. Value measured at junction.

Note: When operating beyond 50°C, the image quality is affected badly with thermal flickering noise all over the image. Continuously operating the camera at 70°C (maximum value) will cause irreparable damage to the camera module. Customers are advised to make necessary arrangements on their products to dissipate the heat generated in the module to maintain the operating temperature below 50°C.

Mechanical Specifications

Tara size is 95mm x 17mm without casing. The board drawing and dimensions are described below.

9 Tara Dimension

The front and rear assembly diagram of Tara board with mechanical dimensions is shown below.

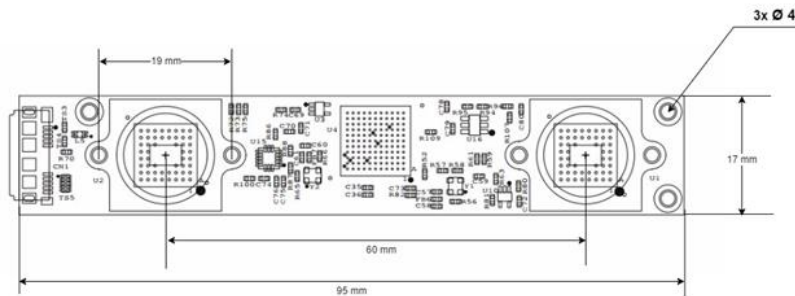

Figure 6: Front Assembly of Tara Board with Mechanical Dimensions

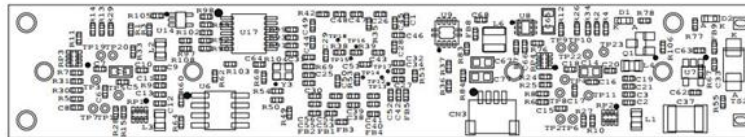

Figure 7: Rear Assembly of Tara Board

10 Lens Holder Dimensions

The lens holder dimensions of Tara are shown below.

Lens Mount Mechanical Dimension

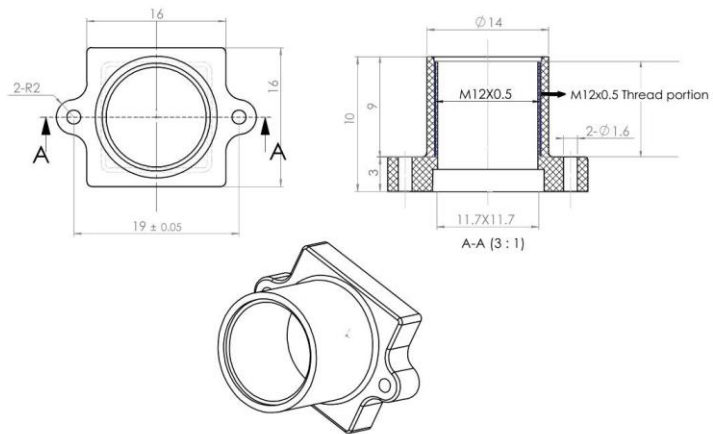

Figure 8: Lens Holder Dimensions

Contact Us

If you need any support on Tara product, please contact us using the Live Chat option available on our website - <https://www.e-consystems.com/>

Creating a Ticket

If you need to create a ticket for any type of issue, please visit the ticketing page on our website - <https://www.e-consystems.com/create-ticket.asp>

RMA

To know about our Return Material Authorization (RMA) policy, please visit the RMA Policy page on our website - <https://www.e-consystems.com/RMA-Policy.asp>

General Product Warranty Terms

To know about our General Product Warranty Terms, please visit the General Warranty Terms page on our website - <https://www.e-consystems.com/warranty.asp>

Revision History

Rev	Date	Description	Author
1.0	05-Apr-2016	Initial Draft	Camera Hardware Team
1.1	13-Jul-2016	Changes added for REV B	Camera Team
1.2	13-Oct-2016	Added Updates	Camera Team
1.3	29-May-2017	Added Updates	Camera Team
1.4	29-Aug-2017	Added FOV and Crop details	Camera Team