

MOVIA 2-AXIS SCAN HEAD

# COMPACT SCAN HEAD FOR INDUSTRIAL MARKING, CODING, AND MICROMACHINING SYSTEMS

Novanta develops photonics solutions through our globally recognized brands— ARGES, Cambridge Technology, Laser Quantum and Synrad— specializing in cutting-edge components and sub-systems for laser-based diagnostic, analytical, micromachining and fine material processing applications. Powerful lasers, coupled with advanced beam steering and intelligent sub-systems incorporating software and controls, deliver extreme precision and performance, tailored to our customers’ demanding applications.

## NEXT GENERATION OF SCAN HEADS

Cambridge Technology’s next generation of 2-axis scan heads feature a compact, industrial design with improved throughput and uptime. Designed for easy system integration due to its compact size and industry-standard interfaces, MOVIA is well-suited for a variety of marking and coding processes. Specifically those that require high throughput and consistent, reliable quality when repeating marks. MOVIA is ideal for non-contact marking of logos, alpha-numeric codes, barcodes, graphics, expiration dates, and many other applications. It has passed numerous extreme condition tests to ensure reliability and safety and is IP50 rated.



## IMPROVED PERFORMANCE

- Easily integrated into existing systems due to its small size and support of industry standard interface and connectors
- High quality character marking resulting from improved electronics and tuning design
- Tested to perform under extreme conditions to ensure high quality and reliability
- Tested with other Novanta products including Synrad’s CO<sub>2</sub> lasers and Cambridge Technology’s ScanMaster Controller



Marking & Coding



Micromachining

## EXAMPLE OF TYPICAL CHARACTER MARKING<sup>1</sup>

ABCDEFGHIJKLMNOPQRSTUVWXYZ  
 abcdefghijklmnopqrstuvwxyz  
 0123456789

CPS 800

ABCDEFGHIJKLMNOPQRSTUVWXYZ  
 abcdefghijklmnopqrstuvwxyz  
 0123456789

CPS 1000

**References:**

1. Examples shown using 160 mm F-Theta lens and single stroke 1 mm characters, SIMPLEX font. Used with ScanMaster Controller. More examples and full parameter set available upon request.

## MOVIA 2-AXIS SCAN HEAD

Specifications	10 mm
Mirror Aperture Size	10 mm
Tune Type	Vector tune
Scan Angle	±20°
Beam Displacement	12.05 mm
Step Response Time 1% of Full Scale <sup>1</sup>	<210 μs
Typical Marking Speed <sup>2</sup>	3 m/s
Typical Positioning Speed <sup>2</sup>	16 m/s
Repeatability	<3.5 μrad
Tracking Error	<130 μs
Linearity	> 99.9% over 20°
Wavelength Options <sup>3</sup>   Max Power	CO <sub>2</sub> : 9.2 - 10.6 μm   125 W Fiber: 1040 - 1090 nm   125 W Green: 532 nm   check with factory UV: 353 - 357 nm   check with factory
Gain Error	<5 mrad
Zero Offset	<5 mrad
Long Term Offset Drift <sup>4</sup>	<100 μrad
Long Term Scale Drift <sup>4</sup>	<150 ppm
Temperature Offset Drift	<20 μrad/°C
Temperature Scale Drift	<20 ppm/°C
Command Resolution	16 bit
Communication Interface	XY2 - 100
IP Rating	IP50
Power Requirements	±15V, 3A RMS
Operating Temperature	15 °C - 35 °C
Weight (approximate)	1.5 kg
Dimensions (L x W x H)	114 mm x 94 mm x 86 mm

### Notes:

All angles are in optical degrees, unless otherwise noted. All specifications are subject to change without notice.

### References:

1. Settling to within 1% of position. 2. With 160mm F-Theta lens. 3. Supports HeNe laser band. 4. During 24 hours of operation after 30 minutes of warm up, per axis.

# MOVIA 2-AXIS SCAN HEAD

10 MM

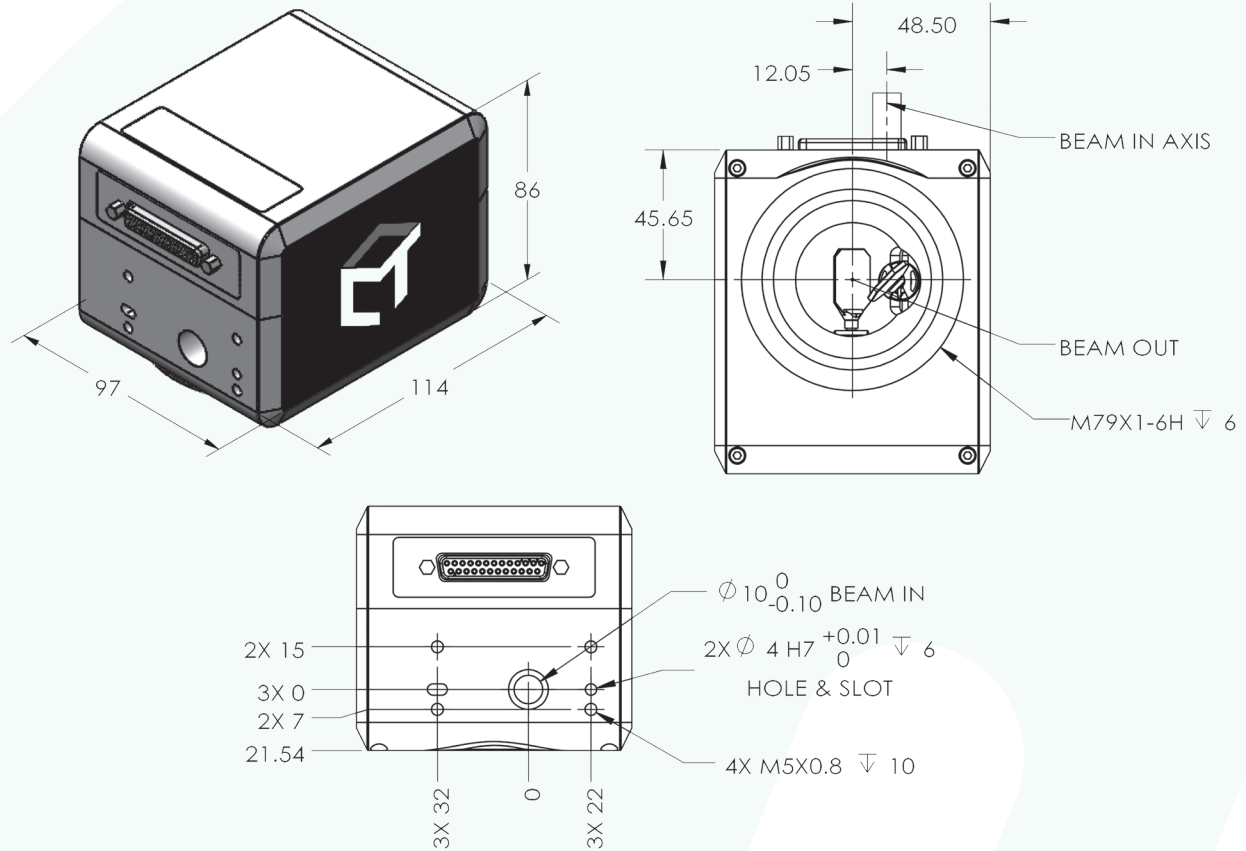

**Notes:**

All angles are in optical degrees, unless otherwise noted. Dimensions are in millimeters. All specifications are subject to change without notice.

Contact factory for accessories inquiries.

## CONTACT US

**Americas, Asia Pacific**

Novanta Headquarters  
Bedford, USA  
P +1-781-266-5700

Photonics@Novanta.com

**Europe, Middle East, Africa**

Novanta Europe GmbH  
Wackersdorf, Germany  
P +49 9431 7984-0

Milan, Italy  
P +39-039-793-710

Photonics@Novanta.com

**China**

Novanta Sales & Service Office  
Shenzhen, China  
P +86-755-8280-5395

Suzhou, China  
P +86-512-6283-7080

Photonics.China@Novanta.com

**Japan**

Novanta Service & Sales Office  
Tokyo, Japan  
P +81-3-5753-2460

Photonics.Japan@Novanta.com