

CNC Plasma Cutting Machines

Designed & Manufactured in the UK

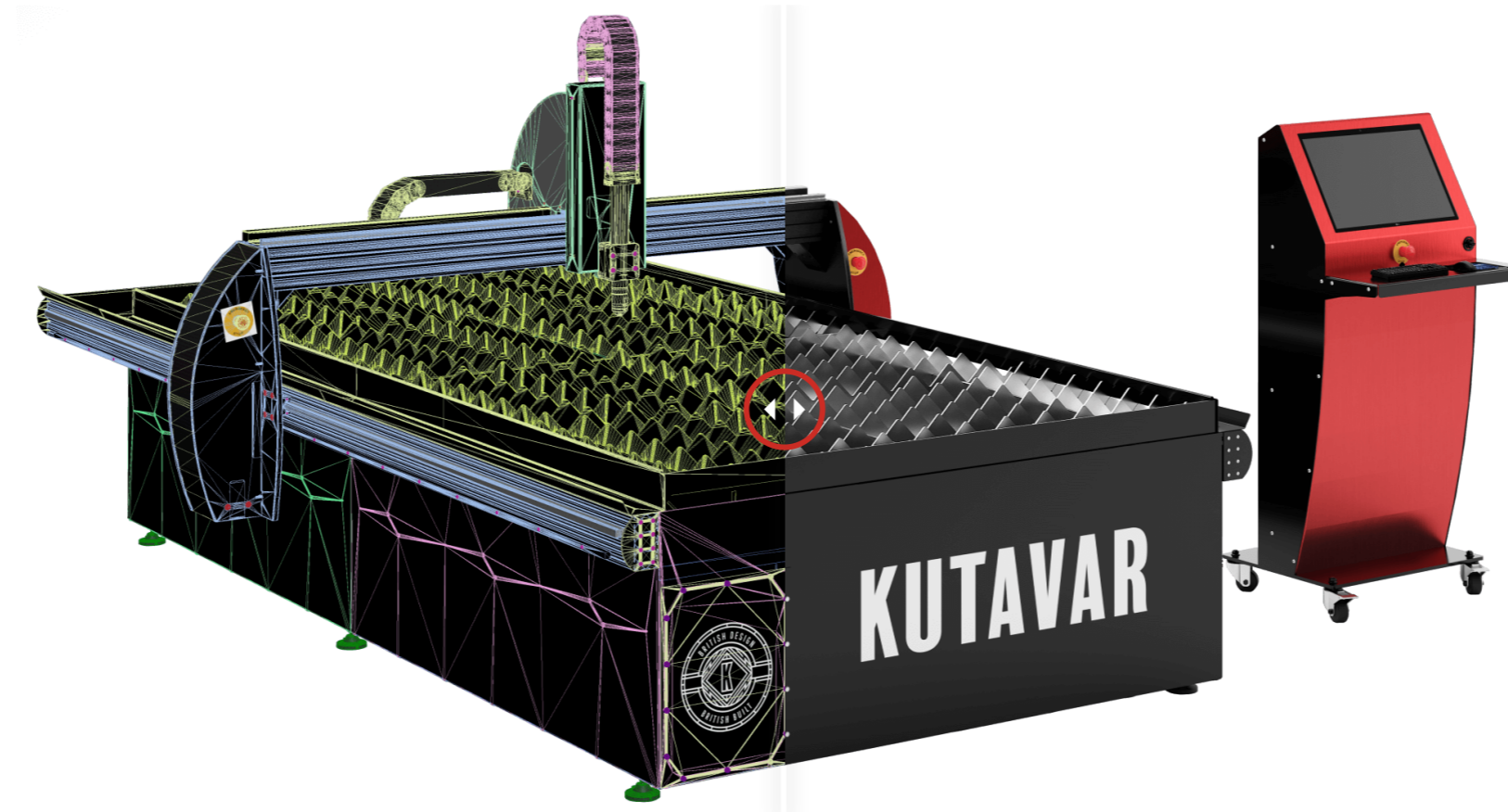

KUTAVAR CNC plasma machines are available in two variants: Water or Zoned Extraction. All machines are highly configurable, designed for use with both air and high-definition plasma.

KUTAVAR has the capability of incorporating oxy-fuel gas cutting in addition to plasma, allowing cut thicknesses of up to 100 mm in mild steel. This is made possible by the heavy-duty design of build, with permissible payloads of up to 5,000 Kg.

*(NB. Zoned Extraction machines only).

BRITISH MANUFACTURING

KUTAVAR - Designed and manufactured to be the best in class

We thought of every detail, designing each individual component to seamlessly fit together to produce machines that our customer's demand.

A machine that is robustly engineered and built, capable of consistently performing in the most challenging of working environments, whilst producing guaranteed accuracy.



KUTAVAR CNC Table

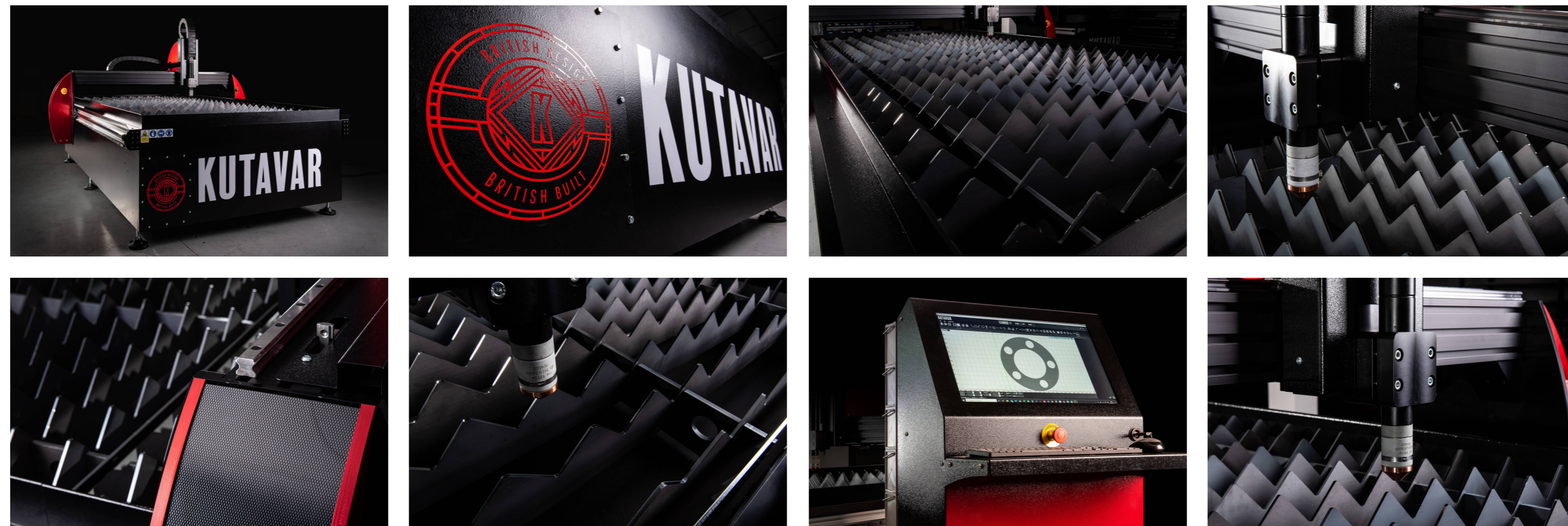

GALLERY

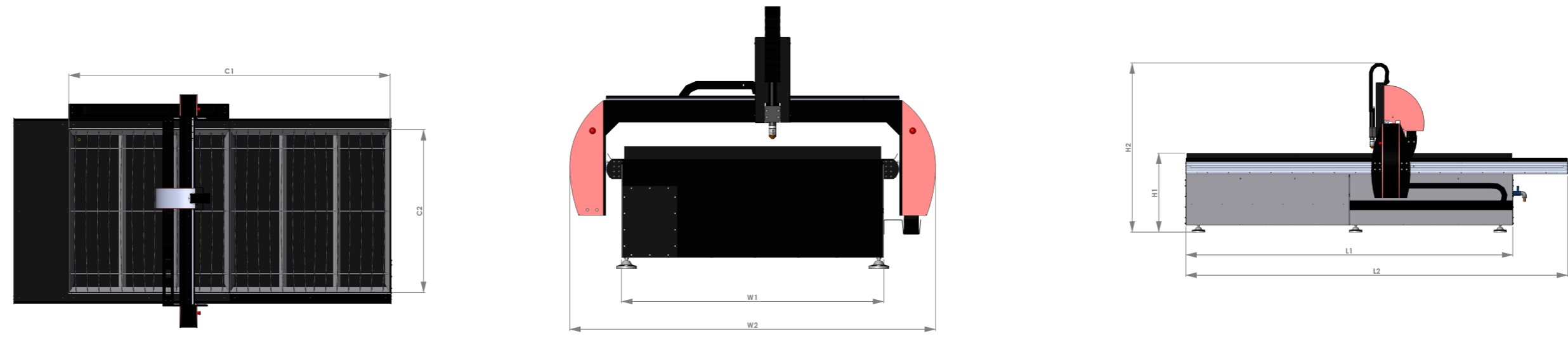

Excel Copy PDF

Reference ▾	1250 x 1250 ▲	2500 x 1250 ▲	3000 x 1500 ▲	4000 x 2000 ▲
W2	1980	1980	2230	2730
W1	1350	1350	1600	2100
L2	2065	3095	3610	4640
L1	1545	2575	3090	4120
H2	1600	1600	1600	1600
H1	750	750	750	750
C2	1250	1250	1500	2000
C1	1250	2500	3000	4000
Reference	1250 x 1250	2500 x 1250	3000 x 1500	4000 x 2000

Excel Copy PDF

Drive Motors ▲	DTHC ▲	IHS ▲	AVC ▲	AHS ▲	Software ▲	Breakaway Head ▲
150W QV stepper	✓	✓	✓	✓	✓	✓
150W QV stepper	✓	✓	✓	✓	✓	✓
150W QV stepper	✓	✓	✓	✓	✓	✓
150W QV stepper	✓	✓	✓	✓	✓	✓
Drive Motors	DTHC	IHS	AVC	AHS	Software	Breakaway Head

Powered by Hypertherm & Kjellberg

KUTAVAR CNC plasma tables are distributed by the two leading brands in plasma cutting, Hypertherm and Kjellberg. Depending on which power source is selected, a maximum pierce capacity of 32 mm is achievable on mild steel, and 25 mm on aluminium and stainless steel. There is a power source available to suit all applications.

[HYPERTHERM](#)[KJELLBERG](#)
[Excel](#)
[Copy](#)
[PDF](#)

POWERSOURCE ^	PMX45 XP ^	PMX65 ^	PMX85 ^	PMX105 ^	PMX125 ^	MAXPRO200 ^
Pierce Capacity (MS)	12 mm	16 mm	20 mm	20 mm	25 mm	32 mm
Pierce Capacity (SS)	12 mm	12 mm	16 mm	20 mm	20 mm	22 mm
Pierce Capacity (ALU)	10 mm	12 mm	16 mm	20 mm	25 mm	22 mm
Output Current	20-45A	20-65A	25-85A	30-105A	30-125A	200A
GAS SUPPLY	Air or N ² / F ₅	Air or N ² / F ₅	Air or N ² / F ₅	Air or N ² / F ₅	Air or N ² / F ₅	Air / Air O ₂
INPUT VOLTAGE	230 V, 1-PH 415 V, 3-PH	415 V, 3-PH	415 V, 3-PH	415 V, 3-PH	415 V, 3-PH	415 V, 3-PH
POWERSOURCE	PMX45 XP	PMX65	PMX85	PMX105	PMX125	MAXPRO200

SIGN UP TO OUR NEWSLETTER

[SIGN ME UP](#)

KUTAVAR

sales@kutavar.com
01432 805700

EXPLORE

Our Tables
Our Software
Become a Distributor
Live at EuroBlech

RESOURCES

Configure & Build
Book a Demo
Download Brochure
Gallery

POLICIES

Privacy Policy
Cookie Policy

