

# iStar CCD series

Fast gated ICCD solutions

## Intensified CCDs for Time-resolved Spectroscopy

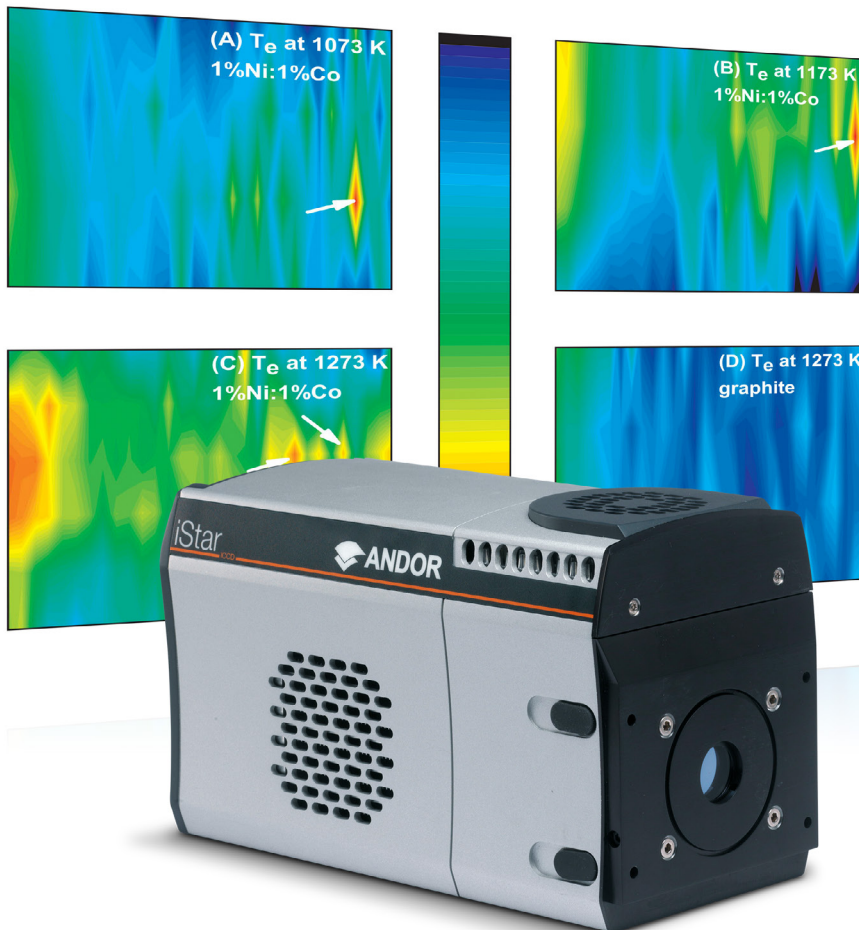

### Key Specifications

- < 2 ns true optical gate
- Up to 3,450 spectra/s
- Integrated triple output DDG
- Photocathode peak QE up to 50%
- Integrate-On-Chip gating up to 500 kHz
- -40°C TE cooling
- USB2 interface

### Key Applications

- ✓ Plasma studies & LIBS
- ✓ Time-resolved Fluorescence/Photoluminescence
- ✓ Time-resolved Raman
- ✓ Transient Absorption

# Introducing iStar for Spectroscopy

Andor's iStar extracts the very best from CCD sensor and image intensifier technologies, achieving a superior combination of rapid acquisitions rates and fast, accurate gating performance.

Exceptional detection performances are accessed through high quantum-efficiency image intensifiers, thermo-electric cooling to  $-40^{\circ}\text{C}$ , 500 kHz photocathode gating rates and enhanced intensifier EBI noise reduction.

Low jitter, low insertion delay gating electronics and nanosecond-scale optical gating provide excellent timing accuracy down to a few  $10^{\text{'s}}$  of picoseconds, allowing ultra-precise synchronization of complex experiments through iStar's comprehensive range of input/output triggering options.

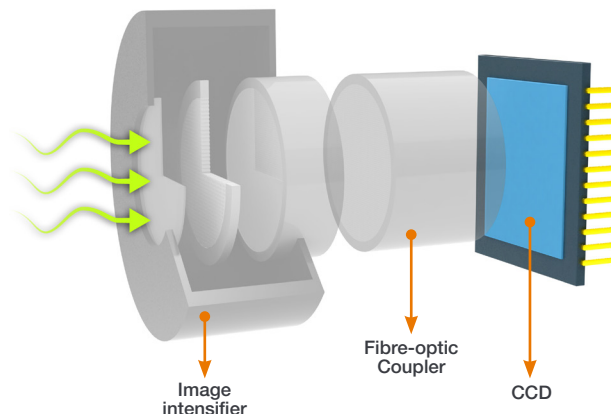

## Meet the family\*<sup>1</sup>

	iStar 320T		iStar 334T	iStar 340T	
Array format	1024 x 255 26 $\mu\text{m}$ pixels		1024 x 1024 13 $\mu\text{m}$ pixels	2048 x 512 13.5 $\mu\text{m}$ pixels	
Active pixels	$\varnothing$ 18 mm tube 690 x 255 pixels 18 x 6.6 mm	$\varnothing$ 25 mm tube 960 x 255 pixels 25 x 6.6 mm	$\varnothing$ 18 mm tube 1024 x 1024 pixels 13.3 x 13.3 mm	$\varnothing$ 18 mm tube 1330 x 512 pixels 18 x 6.9 mm	$\varnothing$ 25 mm tube 1850 x 512 pixels 25 x 6.9 mm
Effective active area (vs image intensifier $\varnothing$ )					
Spectral rate (max, at 16-bit digitization)	323 sps (FVB) 3,571 sps (crop mode) 26,590 sps (fast kinetic)		145 sps (FVB) 3,450 sps (crop mode) 29,850 sps (fast kinetic)	135 sps (FVB) 1,825 sps (crop mode) 16,920 sps (fast kinetic)	
Pixel well depth	500,000 $e^{-}$		100,000 $e^{-}$	100,000 $e^{-}$	
Min read noise ( $e^{-}$ , typical) <sup>2</sup>	7		5	6	
Minimum cooling temperature	$-40^{\circ}\text{C}$				
Image Intensifier options	Gen 2 - Broadband, moderate VUV-NIR QE Gen 3 - VIS-NIR, high QE Gating down to $< 2$ ns (Fast Gen 2 or Gen 3) or $< 100$ ns (High QE Gen 2) Phosphor P43 (fast decay) or P46 (ultrafast decay) options				
Recommended Applications	<ul style="list-style-type: none"> <li>Rapid, broadband spectroscopy</li> <li>Broadband multi-track spectroscopy</li> </ul>		<ul style="list-style-type: none"> <li>High resolution, narrowband spectroscopy</li> <li>Extended fast kinetic series and multi-track</li> </ul>	<ul style="list-style-type: none"> <li>High resolution, broadband spectroscopy</li> <li>High resolution, broadband multi-track spectroscopy</li> </ul>	



**NEW** The iStar sCMOS is Andor's new ultrafast platform for ns time-resolved imaging & spectroscopy.

It features high frame rates up to 40 fps (4,000 with ROI) through a USB3 interface, with the high accuracy gating performance that you would expect from an iStar.

It is the ideal platform for ultrafast, ns time-resolved multi-track spectroscopy and hyperspectral imaging.

# Features & Benefits

## Feature Benefit

Feature	Benefit
High-resolution sensors and image intensifiers	Sharpest images and spectrum definition, 100% fill factor for maximum signal collection efficiency.
True optical gating < 2 ns	Billionth of a second time-resolution for accurate transient phenomena study.
5 MHz readout platform	Rapid frame and spectral rates for superior characterization of dynamic phenomena. Single readout amplifier for best image digitization uniformity.
Superfast readout options Crop & Fast Kinetic mode	Fully customizable binning sequences for highest spectral and image rates. Greater than 6,667 spectra/s continuous rates, up to 55,250 spectra/s in burst mode.
High QE Gen 2 & 3 image intensifiers	Superior photon capture, with peak QE up to 50% and spectral coverage from 120 to 1,100 nm.
Low jitter, on-board Digital Delay Generator (DDG™)	Highest gating timing accuracy with lowest propagation delay. Software controlled 3x triggering outputs with 10 ps setup accuracy for complex experiment integration.
500 kHz sustained photocathode gating	Maximizes signal-to-noise ratio in high repetition rate laser-based applications.
TE-cooling to -40°C	Efficient minimization of CCD dark current and pixel blemishes.
Photocathode EBI minimization	Dry gas purge interface for further efficient EBI reduction.
Intelligate™	Intelligent and accurate MCP gating for better than 1:10 <sup>8</sup> shuttering efficiency in the UV.
Insertion delay as low as 19 ns	Minimum delay between experiment signal generation and actual image intensifier triggering.
USB 2.0 interface	Industry-standard plug-and-play, seamless multi-camera control from single PC or laptop.
Real-time control interface	On-the-fly software control of intensifier gain, gating and 3x outputs trigger parameters for real-time detection optimization.
2 year warranty	Reliability and guaranteed performance over time.



## Deep TE-cooling to -40°C – lowest sensor dark current

- ✓ Experiments involving multi-kHz lasers and extremely weak sample emission, where multiple photocathode gatings can be set within a single CCD exposure. This exposure is typically set to a few seconds to allow for hundreds of thousands of accumulations to occur. During these extended CCD exposures, sensor deep cooling is of the greatest importance.
- ✓ Photon counting, where any noise contribution from any element of the ICCD has to be minimized to allow access to the lowest detection threshold. As Image Intensifiers are fibre coupled to the CCD, the photocathode will see some degree of conductive cooling, which will contribute to minimize the EBI. Further thermal noise reduction can be achieved through the iStar's dry gas purge interface.

# Driving the absolute best spectral acquisition rates\*<sup>1</sup>

	320T	334T	340T
<b>Sensor array size</b>	1024 x 255	1024 x 1024	2048 x 512
<b>Pixel size</b>	26 x 26 $\mu\text{m}$	13 x 13 $\mu\text{m}$	13.5 x 13.5 $\mu\text{m}$
<b>Max. readout speed</b>	5 MHz	5 MHz	3 MHz
<b>Spectral rates (FVB)</b>	323 sps	145 sps	135 sps
<b>Crop mode rates (spectral, binned)</b> [number of rows equivalent to a 130 $\mu\text{m}$ high channel]	3,571 sps [5 rows]	3,450 sps [10 rows]	1,825 sps [10 rows]
<b>Fast Kinetics rates vs. channel heights</b>			
26 $\mu\text{m}$	37,990 Hz [1 row]	48,780 Hz [2 rows]	30,030 Hz [2 rows]
50 $\mu\text{m}$	26,590 Hz [2 rows]	29,850 Hz [4 rows]	16,920 Hz [4 rows]
100 $\mu\text{m}$	16,615 Hz [4 rows]	16,805 Hz [8 rows]	10,225 Hz [8 rows]
200 $\mu\text{m}$	9,495 Hz [8 rows]	9,525 Hz [15 rows]	4,975 Hz [15 rows]
<b>Frame rates (full frame)</b>	15.9 fps	4.2 fps	2.5 fps

## Crop mode: Pushing frame and spectral rates further...

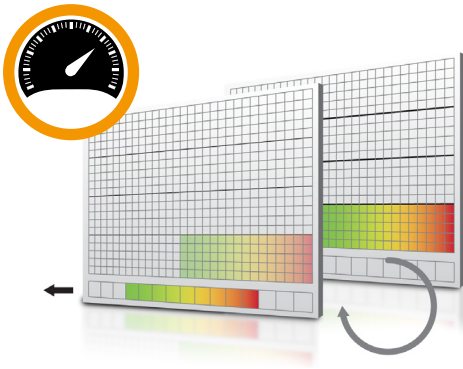

The active imaging area of the sensor is defined in a way that only a small section of the entire chip is used for imaging or spectral acquisition.

The remaining area has to be optically masked to prevent light leakage and charge spill-over that would compromise the signal from the imaging area.

By cropping the sensor, one achieves faster frame and spectral rates because the temporal resolution will be dictated only by the time it requires to read out the small section of the sensor.

## ... and beyond with fast kinetic mode

**T1** - CCD "Keep Clean" sequence is interrupted, and useful signal builds-up on the user-defined top portion of a sensor

**T2** - At the end of the exposure time, signal is rapidly shifted down by a pre-defined number of rows, and a second exposure takes place

**T3** - This process is repeated until the number of acquisitions equals the series length set by user

**T4** - The sequence moves into the readout phase by shifting in turn the individual acquisitions to the readout register, which is then read out

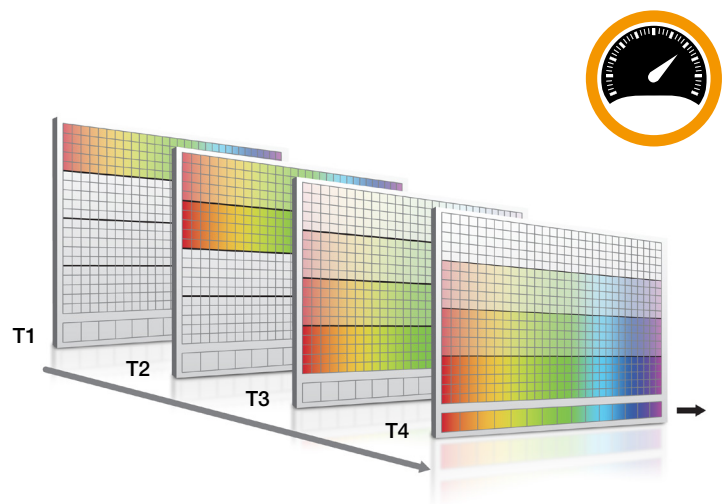

Advanced camera specifications\*<sup>1</sup>

	DH320T		DH334T	DH340T	
<b>Array format</b>	1024 x 255 26 µm pixels		1024 x 1024 13 µm pixels	2048 x 512 13.5 µm pixels	
<b>Fibre optic taper magnification</b>	1:1		Ø18 mm: 1:1 Ø25 mm: 1.5:1 (effective pixel size 19.5 x 19.5 µm)	1:1	
<b>Read noise / e<sup>-</sup>, typ. (max)</b>					
<b>50 kHz</b>	7 (9)		5 (7)	6 (8)	
<b>1 MHz</b>	12 (13)		8 (12)	9 (12)	
<b>3 MHz</b>	19 (20)		14 (18)	12 (18)	
<b>5 MHz</b>	25 (32)		20 (50)	Focusing mode only	
<b>Register well depth</b>	550,000 e <sup>-</sup>		150,000 e <sup>-</sup>	150,000 e <sup>-</sup>	
<b>Minimum cooling temperature [dark current, e<sup>-</sup>/pix/s]</b>	Ø18 mm	Ø25 mm	Ø18 mm	Ø18 mm	Ø25 mm
<b>Air cooled</b>	-30°C [0.4]	-25°C [0.8]	-30°C [0.15]	-30°C [0.15]	-25°C [0.3]
<b>Coolant chiller @ 10°C, 0.75 l/min</b>	-40°C [0.1]	-35°C [0.2]	-40°C [0.04]	-40°C [0.04]	-35°C [0.08]
<b>Vertical shift speeds</b>	5.7 to 22.5 µs		6.5 to 12.9 µs	6.5 to 27.5 µs	
<b>Sensitivity</b>	2 to 10 e <sup>-</sup> /count		1 to 5 e <sup>-</sup> /count	1 to 5 e <sup>-</sup> /count	
<b>Sensor linearity</b> * <sup>3</sup>	Better than 99%				
<b>Digitization</b>	16-bit				

## Camera and Internal Digital Delay Generator (DDG) Inputs/Outputs

<b>Gate pulse delay &amp; width</b>	Adjustable from 0 ns to 10 s in 10 ps steps
<b>Trigger Outputs</b>	
<b>Output A, B and C</b>	+5 V CMOS level with 50 Ω source impedance; can drive 5V into a non-terminating load or 2.5V into 50 Ω load; output synchronized triggers for auxiliary equipment, e.g. lasers, flash lamps, National Instrument™ hardware Individual delays control from 0 ns to 10 s in 10 ps steps Configurable Polarity
<b>Fire</b>	5 V CMOS level reference signal for beginning and end of individual sensor exposure
<b>Arm monitor</b>	5 V CMOS level reference signal to indicate when system is ready to accept external triggers. Signal goes high when system is ready to accept external triggers (after a readout has finished or sooner if in overlap mode) and goes low when the exposure is finished
<b>Gate &amp; output A, B and C jitter</b>	35 ps rms (relative to external trigger or to each other)
<b>Trigger Inputs</b>	
<b>External trigger</b>	Trigger input for sensor and Digital Delay Generator Up to 500 kHz for Integrate-On-Chip mode
<b>Direct gate</b>	TTL input for exact external control of photocathode width and timing with smallest insertion delay.
<b>Additional Controls</b>	
<b>Gate monitoring</b>	AC coupling from photocathode to monitor exact photocathode on/off switching and timings
<b>Insertion delay</b>	< 19 ns in direct gate operation

# Specifications: Gen 2 image intensifiers<sup>\*1</sup>

Photocathode model	18*-03	18*-05 †	18H-13	18H-83	18*-E3 <sup>4</sup>	25*-03
Useful aperture	Ø18 mm (Ø25 mm available- contact Andor for information)		Ø18 mm only			Ø25 mm
Input window	Quartz	MgF <sub>2</sub>	Quartz	Quartz	Quartz	Quartz
Photocathode type	W-AGT	W-AGT	WR	UW	WE-AGT	W-AGT
Minimum guaranteed peak QE @ room temperature <sup>*5</sup>	18	15	13.5	25	22	16
Wavelength range	180 - 850 nm	120 - 850 nm	180 - 920 nm	180 - 850 nm	180 - 850 nm	180 - 850 nm
Phosphor type [decay time to 10%] Standard Optional**	P43 [2 ms] P46 [200 ns]					
Image intensifier resolution limit <sup>*6</sup> P43 (Standard) P46 (Optional)	25 µm 30 µm [-04 model]	25 µm 30 µm	25 µm 30 µm [-14 model]	25 µm 30 µm [-84 model]	25 µm 30 µm [-E4 model]	35 µm 40 µm [-04 model]
Minimum optical gate width (ns) <sup>*7,8</sup> U (Ultrafast) F (Fast) H (High QE)	< 2 < 5 -	< 5 < 10 -	- - < 50	- - < 100	< 2 < 5 -	< 3 < 7 -
Maximum relative gain <sup>*9</sup>	> 1000 [P43] > 500 [P46]	> 1000	> 850	> 500	> 300	> 1000
Maximum photocathode repetition rate (with Intelligate™ OFF)	500 kHz (continuous)					
Maximum photocathode repetition rate (with Intelligate™ ON)	5 kHz (continuous)					
Equivalent Background Illuminance (EBI)	< 0.2 photoe/pix/sec		< 0.4 photoe/pix/sec		< 0.2 photoe/pix/sec	

\* Substitute with appropriate gate width option, e.g. 18F-03 (please refer to page 9 for detailed ordering information)

\*\* All photocathode types can be combined with a fast-decay P46 phosphor – please contact your local Andor representative for further information.

† Available with VUV-compatible spectrograph interface

## Quantum Efficiency Curves for Gen 2 Image Intensifiers<sup>\*5</sup>

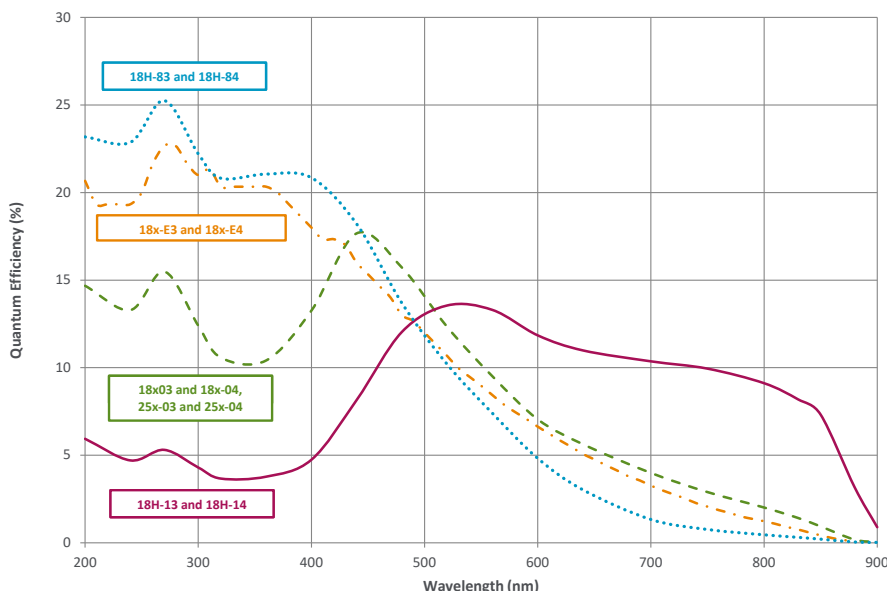

# Specifications: Gen 3 image intensifiers<sup>\*1</sup>

Photocathode model	18*-63	18*-73	18*-93	18*-A3
Useful aperture	Ø 18 mm (Ø 25 mm also available except -93 model contact Andor for information)			
Input window	Glass	Glass	Glass	Glass
Photocathode type	HVS	VIH	NIR	EVS
Typical peak QE @ room temperature <sup>*5</sup>	47.5	25.5	5	40
Wavelength range	280 - 760 nm	280 - 910 nm	380 - 1090 nm	280 - 810 nm
Phosphor type [decay time to 10%] Standard Optional**	P43 [2 ms] P46 [200 ns]			
Image intensifier resolution limit <sup>*6</sup> P43 (Standard) P46 (Optional)	30 µm 35 µm [-64 model]	30 µm 35 µm [-74 model]	30 µm 35 µm [-94 model]	30 µm 35 µm [-A4 model]
Minimum optical gate width (ns) <sup>*8</sup> U (Ultrafast) F (Fast)	< 2 < 5	< 2 < 5	< 3 < 5	< 2 < 5
Maximum relative gain <sup>*9</sup>	> 200			
Maximum photocathode repetition rate (with Intelligate™ OFF)	500 kHz (continuous)			
Maximum photocathode repetition rate (with Intelligate™ ON)	5 kHz (continuous)			
Equivalent Background Illuminance (EBI)	< 0.1 photoe/pix/sec	< 0.3 photoe/pix/sec	< 2 photoe/pix/sec	< 0.2 photoe/pix/sec

\* Substitute with appropriate gate width option, e.g. 18U-63 (please refer to page 9 for detailed ordering information)

\*\*All photocathode types can be combined with a fast-decay P46 phosphor – please contact your local Andor representative for further information

## Quantum Efficiency Curves for Gen 3 Image Intensifiers<sup>\*5,10</sup>

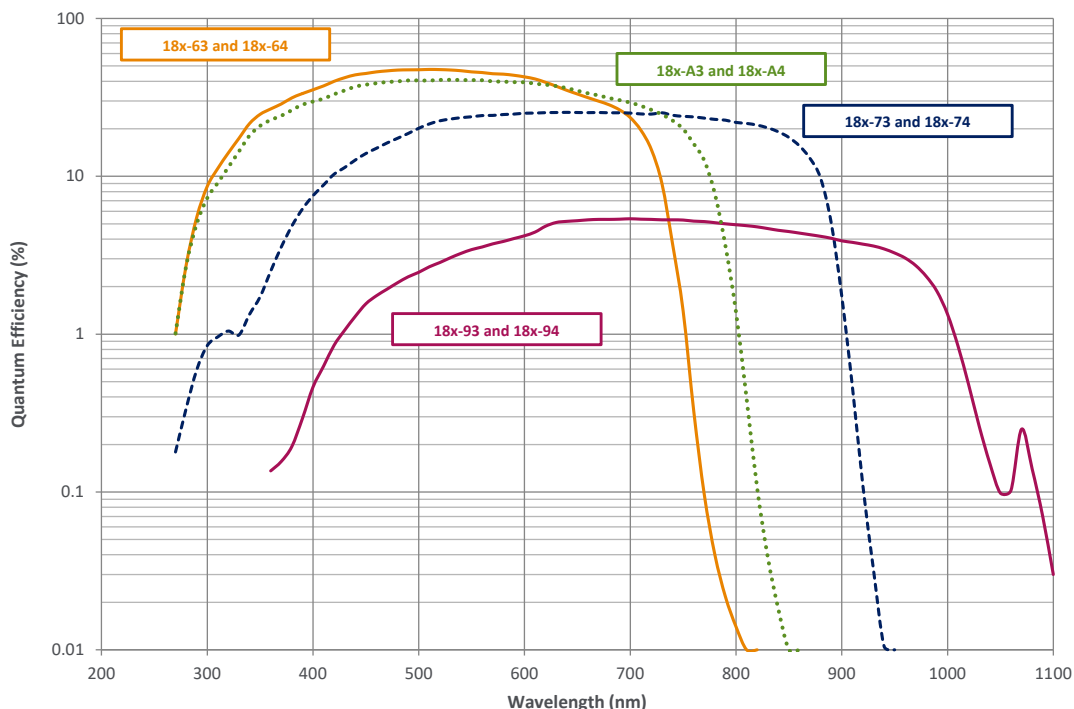

# Intelligent gating modes

## Integrate-On-Chip: 500,000 times more signal per 1 sec CCD exposure

The iStar's Integrate-On-Chip (IOC) mode enables accumulation of useful signal from laser-induced phenomena at frequencies up to 500 kHz, providing greatly improved signal-to-noise, and minimising experiment time. The latter greatly benefits setups where photobleaching-sensitive biological samples are probed. This translates into the possibility to accumulate 500,000 times more signal per 1 second CCD exposure time.

Integrate-On-Chip is fully software-configurable and can be used through extensive kinetic series involving up to 1,000 pre-programmed incremental delays from laser trigger for unrivalled combination of sensitivity and ultra-precise transient phenomena analysis.

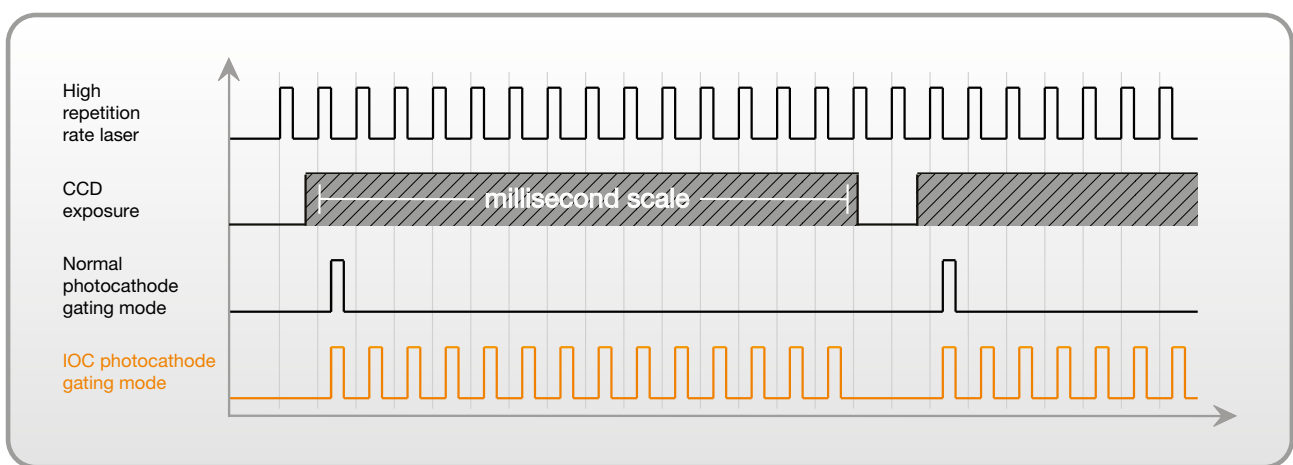

## Intelligate™: Superior gating in the UV-VUV region

One of the key functions of an image intensifier is to provide high optical shuttering (ON/OFF) ratio. By switching photocathode voltage to a higher or lower level relative to the MCP voltage, photo-electrons can be either directed towards or repelled from the MCP to avoid detection. ON/OFF values of  $1:10^8$  are typically measured for Visible/NIR incident light on the photocathode.

However photocathode "leakage" becomes more pronounced in the UV-VUV region ( $< 300$  nm), where more energetic photons have a greater probability to go through the photocathode turned "OFF", reach the MCP to generate an electron that can be detected. This can lead to shuttering efficiency as low as  $1:10^4$ .

Andor's exclusive Intelligate™ simultaneously gates the photocathode and the MCP. The ultra fast rising edge of the MCP gate pulse switches on the correct potential in a nanosecond timeframe, coinciding precisely with the photocathode gating pulse. This enables ON/OFF ratios as high as  $10^8$  in the UV-VUV region.

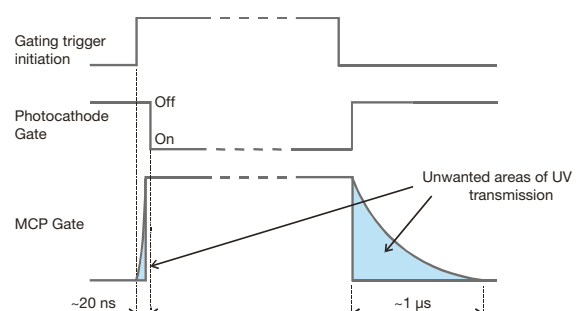
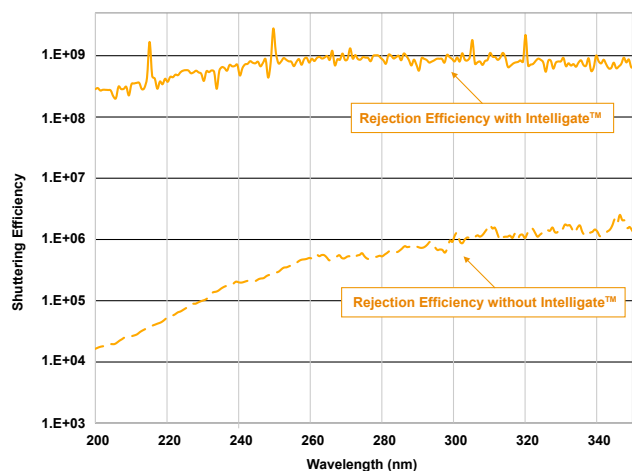



## Creating the optimum product for you



DH **340** T- **18** - **F** - **03** example shown

### Step 1. Choose the CCD matrix size

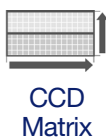

CCD matrix	Code
1024 x 256 CCD matrix, 26 µm pixel	<b>320</b>
1024 x 1024 CCD matrix, 13 µm pixel	<b>334</b>
2048 x 512 CCD matrix, 13.5 µm pixel	<b>340</b>

### Step 2. Choose the intensifier diameter



Intensifier Diameter

Intensifier diameter	Code
Ø 18 mm	<b>18</b>
Ø 25 mm	<b>25</b>

Please contact Andor regarding Ø 25 mm options, note 1.5:1 taper for DH334 model.

### Step 3. Choose a minimum gating speed



GATING SPEED  
Gating Speed

Gating Speed	Code
High QE, slow gating	<b>H</b>
Fast Gating	<b>F</b>
Ultra Fast Gating	<b>U</b>

### Step 4. Select an image intensifier option



Intensifier

Gen 2 Intensifier option	Code
W-AGT photocathode, P43 phosphor	<b>03</b>
W-AGT photocathode, P46 phosphor	<b>04</b>
W-AGT photocathode, MgF <sub>2</sub> window, P43 phosphor	<b>05</b>
WR photocathode, P43 phosphor	<b>13</b>
UW photocathode, P43 phosphor	<b>83</b>
WE-AGT photocathode, P43 phosphor	<b>E3</b>

Gen 3 Intensifier option	Code
HVS photocathode, P43 phosphor	<b>63</b>
VIH photocathode, P43 phosphor	<b>73</b>
NIR photocathode, P43 phosphor	<b>93</b>
EVS photocathode, P43 phosphor	<b>A3</b>

All photocathode types can be combined with a fast-decay P46 phosphor – please contact your local Andor representative for further information

### Step 5. Select the required accessories and adapters

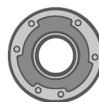

Accessories & Adapters

Description	Order Code
C-mount lens adaptor	<b>LM-C</b>
F-mount lens adaptor	<b>LM-NIKON-F</b>
Oasis 160 Ultra compact chiller unit (tubing to be ordered separately)	<b>ACC-XW-CHIL-160</b>
6 mm tubing options for ACC-XW-CHIL-160 (2x2.5 m or 2x5 m lengths)	<b>ACC-6MM-TUBING-2X2.5/ ACC-6MM-TUBING-2X5M</b>
1°C to BNC cable for Kymera and Shamrock shutter control	<b>ELC-05323</b>
Metric Bracket, converts 1/4-20 mounting points to M6	<b>ACC-ISTAR-METRIC ADP</b>

### Step 6. Select the required software



Software

The iStar ICCD requires at least one of the following software options:

**Solis for Time-Resolved** A 32-bit and fully 64-bit enabled application for Windows (8, 8.1 and 10) offering rich functionality for data acquisition and processing. AndorBasic provides macro language control of data acquisition, processing, display and export.

**Andor SDK2** A software development kit that allows you to control the Andor range of cameras from your own application. Available as 32/64-bit libraries for Windows (8, 8.1 and 10) and Linux. Compatible with C/C++, LabView and Matlab.

## Product drawings

Dimensions in mm [inches]

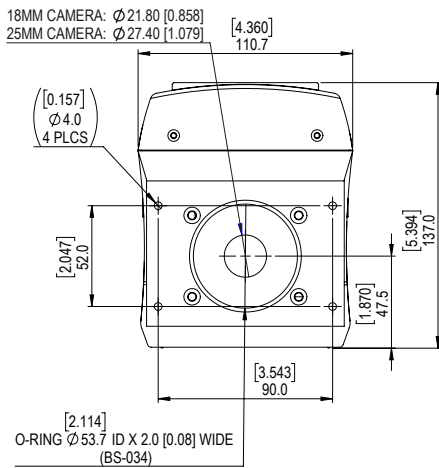

Weight: 4.2 kg [9 lb 4 oz]

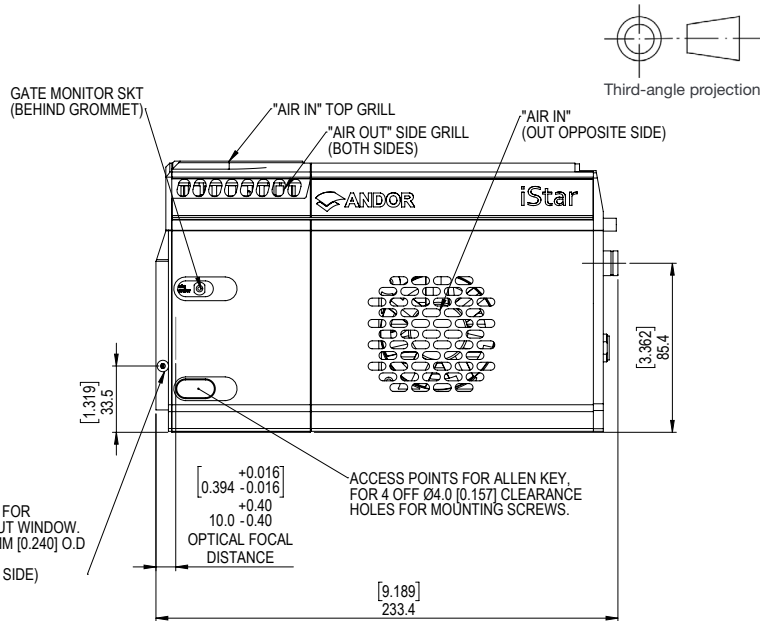

## Connecting to the iStar

### Camera Control

Connector type: USB 2.0

### Logic Input / Output

Connector type: SMA, provided with SMA - BNC cable  
5x outputs: FIRE pulse, Output A, B, C from DDG™ and ARM  
2x inputs: Camera trigger from 3<sup>rd</sup> party source & direct gate for complete, direct external control of intensifier gating

### I<sup>2</sup>C connector

Compatible with Fischer SC102A054-130, pin-outs as follow:  
1 = Shutter (5V CMOS level with 50  $\Omega$  impedance), 2 = I<sup>2</sup>C Clock (5V), 3 = I<sup>2</sup>C Data (5V), 4 = +5 Vdc, 5 = Ground

### Gate Monitor

1x output: AC coupling to photocathode

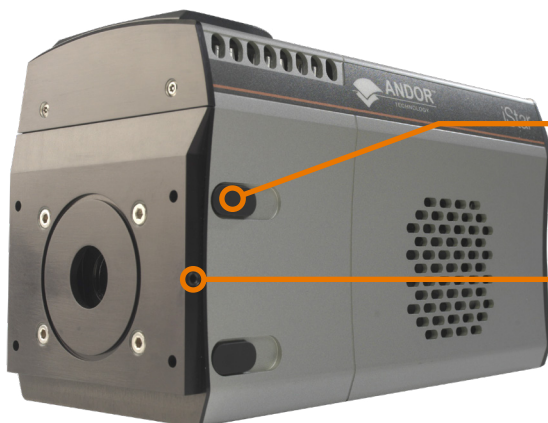
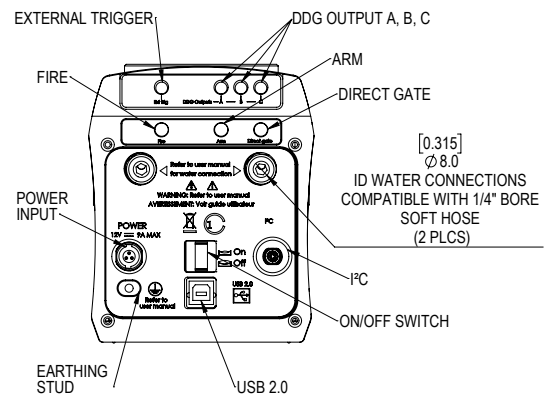
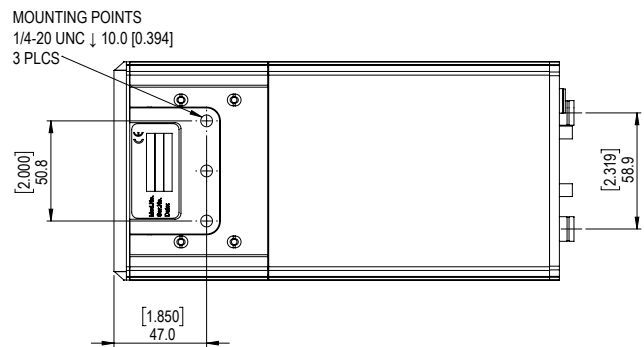

### Gate monitor

AC coupling to photocathode provides the most reliable timing information on actual gating occurrence

### Dry gas purge

Minimizes Electron Background Illumination (EBI) thermally generated at the photocathode to improve detection threshold



## ORDER TODAY

Need more information? At Andor we are committed to finding the correct solution for you. With a dedicated team of technical advisors, we are able to offer you one-to-one guidance and technical support on all Andor products. For a full listing of our regional sales offices, please see: [andor.com/contact](http://andor.com/contact)

Our regional headquarters are:

### EUROPE

Belfast, Northern Ireland  
Phone +44 (28) 9023 7126  
Fax +44 (28) 9031 0792

### JAPAN

Tokyo  
Phone +81 (3) 6732 8968  
Fax +81 (3) 6732 8939

### NORTH AMERICA

Concord, MA, USA  
Phone +1 (860) 290 9211  
Fax +1 (860) 290 9566

### CHINA

Beijing  
Phone +86 (10) 5884 7900  
Fax +86 (10) 5884 7901

### ITEMS SHIPPED WITH YOUR CAMERA

- 1x 12V, 120W single line Power Supply Unit
- 2x 2 m BNC to SMA cable
- 1x Gate Monitor cable
- 1x 3 m USB cable A to B type, shielded
- 1x CD containing Andor user guides
- 1x Individual system performance booklet

### Regulatory Compliance

Compliant with the requirements of the EU EMC and LV Directives through testing to EN 61326-1 and EN 61010-1.  
External power supply PSE-approved

### Footnotes: Specifications are subject to change without notice

1. Figures are typical unless otherwise stated.
2. Measured for the entire system. Combination of CCD readout noise and A/D noise - measurement is for single pixel readout with -30°C CCD cooling and at minimum exposure time under dark conditions. Values quoted are measured with highest available PAG setting.
3. Linearity is measured from a plot of counts vs exposure time under constant photon flux up to the saturation point of the system.
4. The On/Off ratio of the 'E3' image intensifier in the UV with MCP gating is typically 10<sup>5</sup>.
5. Typical photocathode Quantum Efficiency and input window transmission as measured by the tube manufacturer.
6. Typical resolution of the image intensifier tube only, not the overall resolution of the system. As a rough guide, the smallest resolvable FWHM feature will be approximately 2x the CCD pixel size. This is a very important consideration for optical resolution calculations in spectrograph-based systems.
7. Gen 2 High QE (H) option - Photocathode QE is inherently linked to the gating speed of the intensifier. High QE option (H) offers higher peak QE than Ultrafast (U) or Fast (F) intensifiers, while exhibiting minimum gating speed one order of magnitude slower.
8. Actual measured minimum optical gating of the photocathode, reflecting not only the electrical pulse width applied to the photocathode but also its inherent iris time.
9. Gain is software-selectable through a 12-bit DAC and varies exponentially with DAC setting. Value refers to the ratio of max to min intensifier gain as measured for individual cameras. Actual optical gain (counts/ photoe) for a DAC setting is accessed by the multiplication of the relative gain (at that DAC value) by the minimum system gain (at DAC = 0, CCD e<sup>-</sup>/photoe) and divided by the sensitivity (CCD e<sup>-</sup>/count) at a given CCD PAG. Sensitivities are individually measured and reported for each system.

**OXFORD**  
INSTRUMENTS

The Business of Science®

### Minimum Computer Requirements:

- 3.0 GHz single core or 2.4 GHz multi core processor
- 2 GB RAM
- 100 MB free hard disc to install software (at least 1 GB recommended for data spooling)
- USB 2.0 High Speed Host Controller capable of sustained rate of 40 MB/s
- Windows (8, 8.1 and 10) or Linux

### Operating & Storage Conditions

- Operating Temperature: 0°C to 40°C ambient
- Relative Humidity: < 70% (non-condensing)
- Storage Temperature: -20°C to 55°C

### Power Requirements

- Power: +12 VDC ± 5% @ 5A typ. / 9A max.
  - Ripple: 120 mV peak-peak 0 - 20 MHz
  - 100 - 240 VAC, 43 - 67 Hz External power supply
  - Power Consumption:
- Camera + External Power Supply (Typ./ Max.):  
69W/124W. Camera Only (Typ./ Max.): 60 W/108 W



Windows is a registered trademark of Microsoft Corporation. Labview is a registered trademark of National Instruments. Matlab is a registered trademark of The MathWorks Inc.

LISTARSS 0220 R1 (QD)