

## FINESSE DPSS CONTINUOUS WAVE LASER SERIES

# ULTRA LOW NOISE AND HIGH SPECIFICATION LASERS

Novanta develops photonics solutions specializing in cutting-edge components and sub-systems for laser-based diagnostic, analytical, micromachining and fine material processing applications. Powerful lasers, coupled with advanced beam steering and intelligent sub-systems incorporating software and controls, deliver extreme precision and performance, tailored to our customers' demanding applications.

## DESIGNED FOR SPECIFICATION

The finesse range of lasers offer top of the range performance at a high-power output of up to 16W. A novel cavity design and clever integrated electronics deliver exceptional power stability and ultra-low noise making this product ideal for the highly demanding Ti:S pumping applications whilst ensuring consistent and repeatable results for the Semiconductor inspection industry. Unique features in the form of CEP stabilization makes the finesse a perfect fit for Carrier Envelope Phase locking applications.

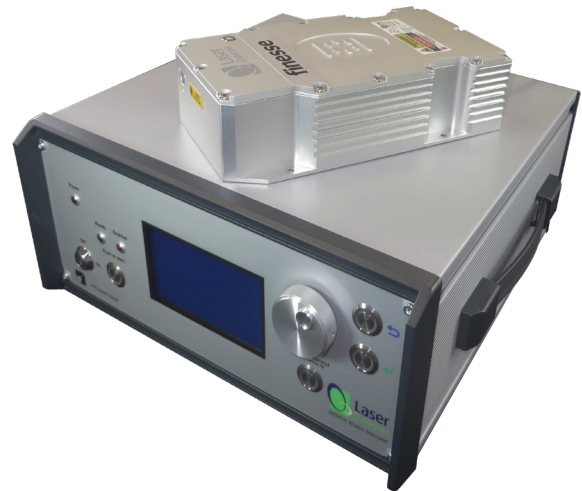

The finesse laser uses pure™ technology producing <0.02 % noise

## UNIQUE FEATURES

**Exceptional power stability and ultra low noise ensure consistent and accurate results.**

- Novel cavity design fundamentally enabling exceptionally stable power output.
- Noise cancellation electronics actively work to deliver ultra low noise

**High power and exceptional wall plug efficiency enables applications.**

- Up to 16W of continuous wave 532nm delivers high power on sample/target
- Exceptional wall plug efficiency results in low heat dissipation and reduces thermal management requirements

**Reduce cost and complexity.**

- CEP feedback loop allows for direct modulation of output using f2f interferometer signal; removing cost and complexity from system design

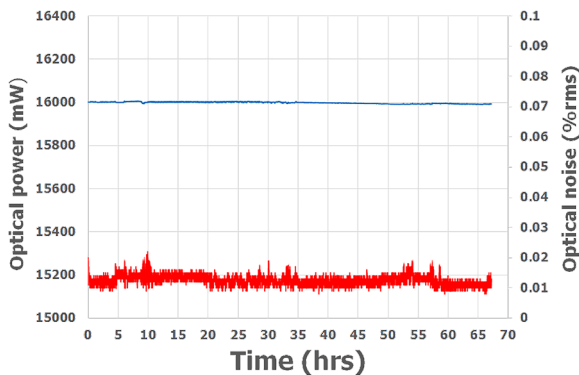

Fig. 1 Typical power and noise stability of the finesse pure laser. Power stability (blue) <0.05 % and the noise (red) ~0.01 % shown over a 70 hour period.

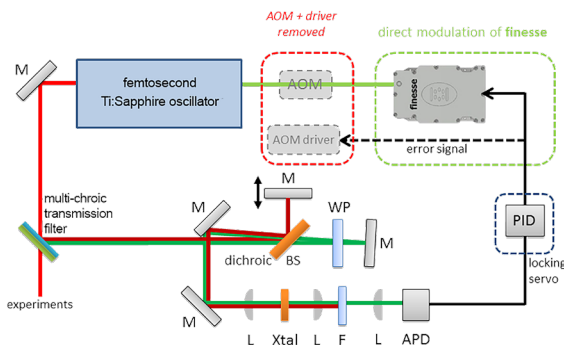

Fig. 2 finesse pure CEP removes the need for an AOM, offering simpler setup design and lower integrated CEP phase noise.

## FINESSE DPSS CONTINUOUS WAVE LASER SERIES SPECIFICATIONS

Specification	finesse 532	finesse 532 pure	finesse 532 pure CEP
Wavelength	532 nm		
Power	14 - 16 W		
Beam Diameter <sup>1</sup>	2.25 mm ± 0.25 mm		
Spatial Mode	TEM <sub>00</sub>		
Ellipticity	< 1:1.15		
Bandwidth	50 GHz		
Divergence	< 0.4 mrad		
M <sup>2</sup>	< 1.1		
Modulation Depth	n/a	n/a	±1%
Modulation Behaviour	n/a	n/a	< 1 MHz
Phase Behaviour	n/a	n/a	-90° for 750 kHz
Power Stability (RMS) <sup>2</sup>	< 0.10%	< 0.100% (< 10 W) < 0.050% (10 W+)	< 0.100% (< 10 W) < 0.050% (10 W+)
Noise (RMS) <sup>3</sup>	< 0.1%	< 0.030% (< 10 W) < 0.020% (10 W+)	< 0.030% (< 10 W) < 0.020% (10 W+)
Noise Bandwidth	10 Hz - 100 MHz		
Beam Pointing Stability	< 2 µrad/ °C		
Polarization Ratio	> 100:1		
Polarization Direction <sup>4</sup>	Horizontal		
Coherence Length	6 mm		
Beam Angle <sup>5</sup>	< 1 mrad		
Operating Temperature	20 - 40° C		

\* Laser Quantum operates a continuous improvement programme which can result in specifications being improved without notice.

1 Beam diameter defined as the average of major and minor 1/e<sup>2</sup> beam size measured at 25 cm from exit port, at specified power.

2 Test duration >100 hrs. at constant temperature.

3 Measured at specified power.

4 Vertical polarization is available upon request.

5 Tolerance relative to head orientation.

# FINESSE DPSS CONTINUOUS WAVE LASER SERIES

## DIMENSIONS (mm)

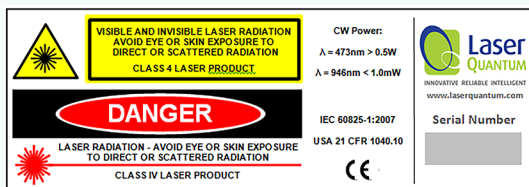
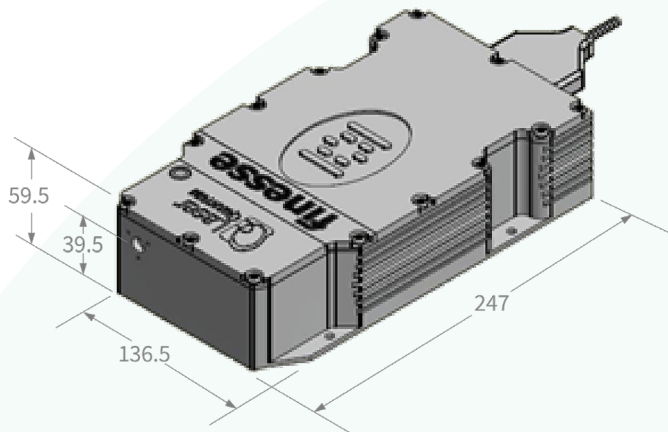

Drawings are for illustrative purposes only, please contact us for complete engineer's drawings

## POWER SUPPLY UNIT

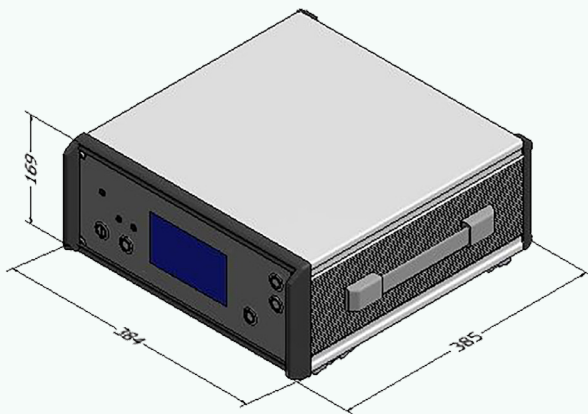

## FLEXIBLE DESIGN

Customizable options available for your laser to optimize your application.

- **Field Replacements:** The finesse range benefits from pump diodes situated in the intelligent power controller to facilitate heat management and allows field replacement.
- **CEPLoQ™ Technology:** directly modulates the pump power to maintain phase stabilization without the use of an AOM; faster and more stable responses than the traditional method.
- **Intelligent control unit:** Allows easy setting and monitoring of the laser parameters. Incorporating PowerLoQ™ technology, the gem lasers show extreme power stability over long periods of use.
- **1200 g drop-test:** (Fig. 2) All gem lasers undergo a drop test to check that all components are correctly fitted prior to its extended 300 hour test period. This rigorous testing regime ensures long operational lifetimes.
- **RemoteApp™:** Works with software that allows the laser to be controlled locally, over the internet and connected directly to our support team for monitoring laser performance

## ADDITIONAL

- Weight: 3 kg
- Umbilical length: 2 m
- Vertical polarization is available on request
- Capable of pumping an commercial Ti:Sapphire oscillator
- Fiber coupling available
- LabView drivers available
- 5 years/15,000 hours (PSU 'on' time) warranty for scientific users

## CONTACT US

### Americas, Asia Pacific

Novanta Headquarters  
Bedford, USA  
P +1-781-266-5700

Photonics@Novanta.com

### Europe, Middle East, Africa

Novanta Europe GmbH  
Wackersdorf, Germany  
P +49 9431 7984-0

Milan, Italy  
P +39-039-793-710

Photonics@Novanta.com

### China

Novanta Sales & Service Office  
Shenzhen, China  
P +86-755-8280-5395

Suzhou, China  
P +86-512-6283-7080

Photonics.China@Novanta.com

### Japan

Novanta Service & Sales Office  
Tokyo, Japan  
P +81-3-5753-2460

Photonics.Japan@Novanta.com