

X-RSW Series: Motorized rotary stages with built-in controllers

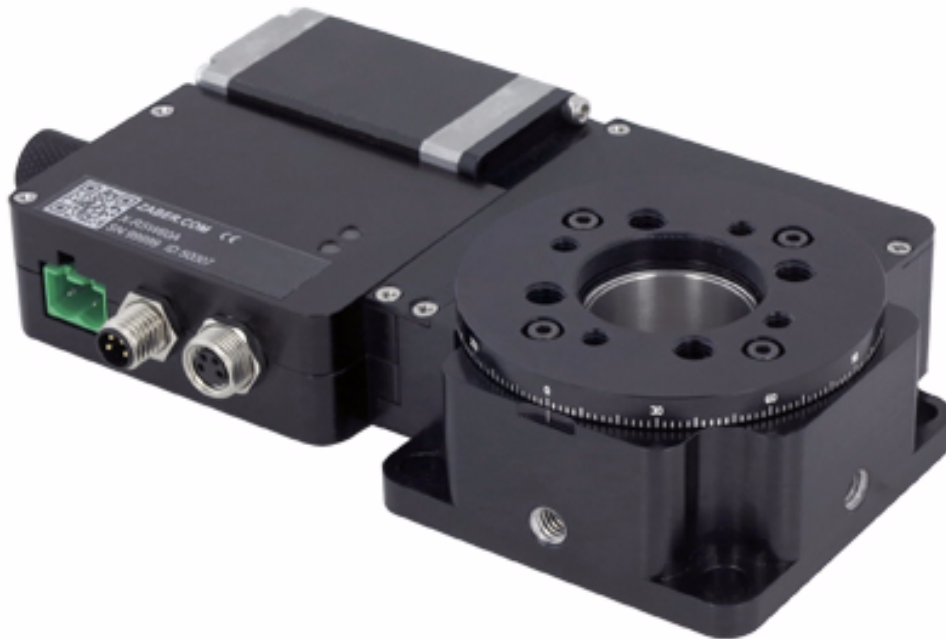

- Worm gear driven for continuous rotation
- Two lens holders allow for use as a polarizer mount
- Speed up to 75 rpm and torque up to 2.25 N-m
- 20 kg centered load capacity
- Built-in controller; daisy-chains with other Zaber products
- Multiple X-Series products in a daisy-chain can share a single power supply

Product Description

We recently released the X-RSW, a new and improved rotary stage. If you are looking for the T-RSW, please see the T-RSW page.

Zaber's X-RSW Series products are motorized rotary stage devices with built-in controllers. Rated for 2.25 N-m of torque they are ideal for high precision, angular positioning applications.

They are stand-alone units requiring only a standard 24-48 V power supply. An indexed knob provides smooth manual control at variable speeds in both directions for versatile operation even without a computer. Press and hold to switch between velocity mode and position mode, turn to move the stage, and press to stop.

The stages connect to the USB 2.0 or RS-232 port of any computer and can be chained with several units per chain. They can be chained with any other Zaber products. Convenient locking, 4-pin, M8 connectors on the unit allow for easy and secure connection between products. The chain also shares power, so multiple X-Series products can use a single power supply.

Dimension Drawings

*See product page for complete list of available models at www.zaber.com

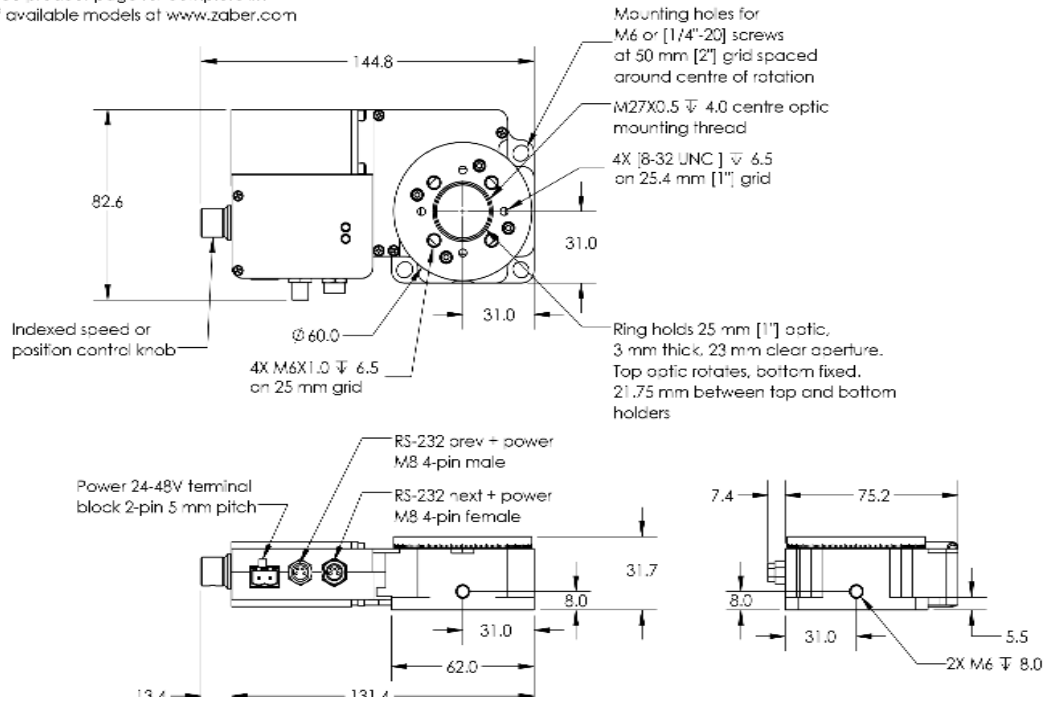

Product Specifications

Specification	Value	Alternate Unit
Built-in Controller	Yes	
Range	360 degrees	
Accuracy (unidirectional)	0.14 degrees	2.443000 mrad
Repeatability	< 0.02 degrees	< 0.349 mrad
Backlash	< 0.04 degrees	< 0.698 mrad
Encoder Type	None	
Communication Interface	RS-232	
Communication Protocol	Zaber ASCII (Default), Zaber Binary	
Maximum Centered Load	200 N	44.9 lb
Maximum Cantilever Load	410 N-cm	580.6 oz-in
Stage Diameter	60 mm	2.362 "
Maximum Current Draw	950 mA	
Power Supply	24-48 VDC	
Power Plug	2-pin Screw Terminal	
Motor Steps Per Rev	200	
Motor Type	Stepper (2 phase)	
Inductance	1 mH/phase	
Default Resolution	1/64 of a step	
Data Cable Connection	Locking 4-pin M8	
Mechanical Drive System	Precision Worm Gear	
Limit or Home Sensing	Magnetic home sensor	
Manual Control	Yes	
Operating Temperature Range	0-50 degrees C	
RoHS Compliant	Yes	
CE Compliant	Yes	
Weight	0.66 kg	

Part Number	Microstep Size (Default Resolution)	Maximum Speed	Minimum Speed	Maximum Continuous Torque
X-RSW60A	0.000234375 degrees (4.091 urad)	115 deg/s (19.2 rpm)	0.000143 deg/s (2.496 urad/s)	225 N-cm (318.6 oz-in)
X-RSW60C	0.0009375 degrees (16.362 urad)	450 deg/s (75.0 rpm)	0.000572 deg/s (9.983 urad/s)	105 N-cm (148.7 oz-in)

Specification Charts

Torque Speed Performance

