

## X-RST Series: High load motorized rotary stages with built-in controllers

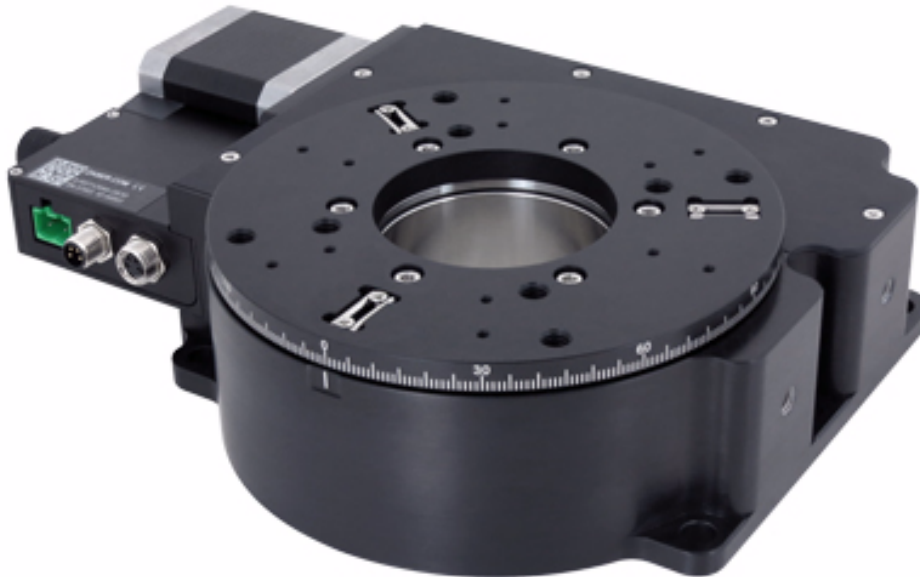

- 50.8 mm (2 inch) aperture with kinematic mounting options for repeatability of assembly
- 50 kg centered load capacity
- Speed up to 24 deg/s; torque up to 10 N-m
- Built-in controller; daisy-chains with other Zaber products
- Multiple X-Series products in a daisy-chain can share a single power supply

### Product Description

Zaber's X-RST Series products are motorized rotation stages with built-in controllers. Rated for a 50 kg centered load capacity and 10 N-m of torque, they are ideal for high load, angular positioning applications.

They are stand-alone units requiring only a standard 24-48 V power supply. An indexed knob provides smooth manual control at variable speeds in both directions for versatile operation even without a computer. Press and hold to switch between velocity mode and position mode, turn to move the stage, and press to stop.

The stages connect to the USB 2.0 or RS-232 port of any computer and can be chained with several units per chain. They can be chained with any other Zaber products. Convenient locking, 4-pin, M8 connectors on the unit allow for easy and secure connection. The chain also shares power, so multiple X-Series products can use a single power supply.

## Dimension Drawings

\*See product page for complete list of available models at [www.zaber.com](http://www.zaber.com)

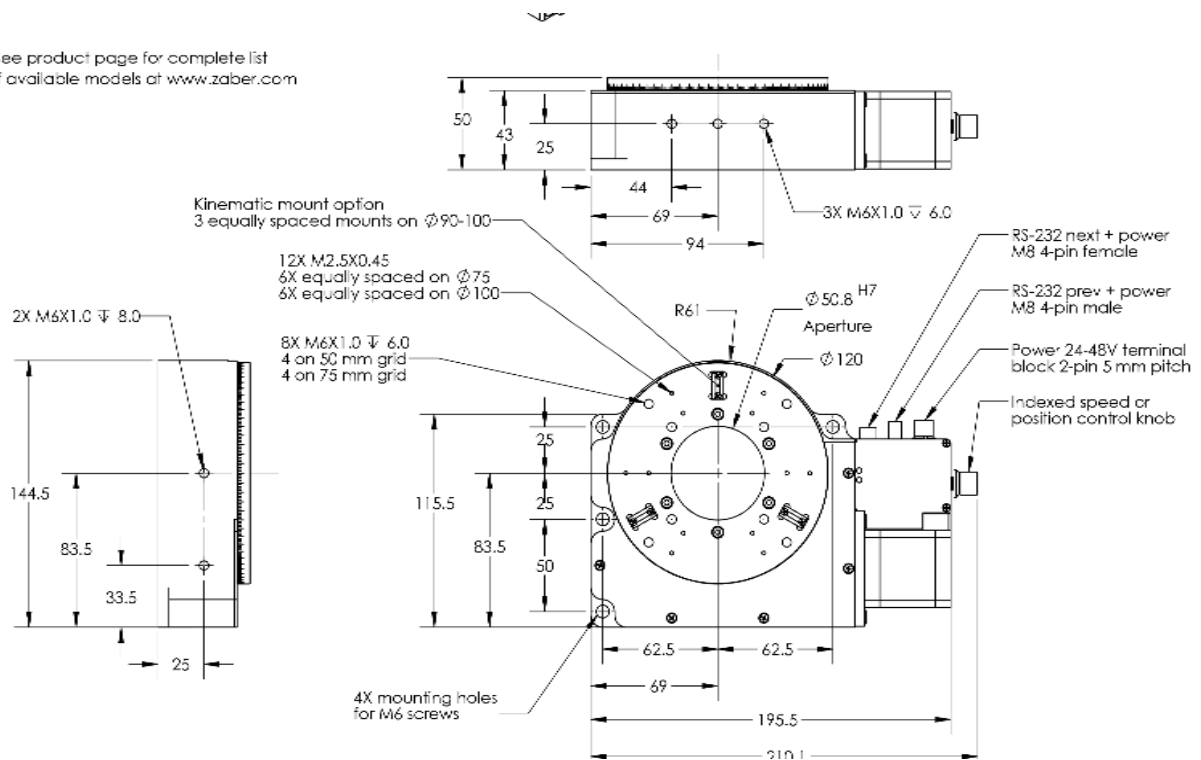

## Product Specifications

Specification	Value	Alternate Unit
Microstep Size (Default Resolution)	0.00015625 degrees	2.727 urad
Built-in Controller	Yes	
Range	360 degrees	
Accuracy (unidirectional)	0.16 degrees	2.792000 mrad
Repeatability	< 0.005 degrees	< 0.087 mrad
Backlash	< 0.05 degrees	< 0.873 mrad
Maximum Speed	24 deg/s	4.0 rpm
Minimum Speed	0.000095 deg/s	1.658 urad/s
Encoder Type	None	
Communication Interface	RS-232	
Communication Protocol	Zaber ASCII (Default), Zaber Binary	
Maximum Continuous Torque	1000 N-cm	1,416.1 oz-in
Maximum Centered Load	500 N	112.1 lb
Maximum Cantilever Load	2000 N-cm	2,832.2 oz-in
Stage Diameter	120 mm	4.724 "
Maximum Current Draw	1100 mA	
Power Supply	24-48 VDC	
Power Plug	2-pin Screw Terminal	
Motor Steps Per Rev	200	
Motor Type	Stepper (2 phase)	
Inductance	6.6 mH/phase	
Maximum Angular Momentum	0.4 kg-m <sup>2</sup> /s	
Default Resolution	1/64 of a step	
Data Cable Connection	Locking 4-pin M8	
Mechanical Drive System	Precision Worm Gear	
Limit or Home Sensing	Magnetic home sensor	
Manual Control	Yes	
Operating Temperature Range	0-50 degrees C	
RoHS Compliant	Yes	
CE Compliant	Yes	
Weight	2.4 kg	

Specification Charts

Torque Speed Performance

