



LINEAR BEARINGS

and Recirculating Units

Latest version of the catalogs

You can always find the latest version of our catalogs in the Download area of our website.

Disclaimer

This publication has been compiled with great care and all information has been checked for accuracy. However, we can assume no liability for incorrect or incomplete information. We reserve the right to make changes to the information and technical data as a result of enhancements to our products. Reprinting or reproducing, even in part, is not permitted without our written consent.



1	Foreword	3
2	Useful guidelines	4
2.1	2D- and 3D-drawings	4
2.2	Regulations governing substances and limit values	4
2.3	Index and type designations	5
2.4	Description of the units	9
3	Product overview	11
3.1	Overview of linear guideways	11
3.2	Overview of recirculating units	13
3.3	Earlier generations of the product	14
3.4	Slideways	15
3.5	Application-specific solutions	15
4	Applications	17
5	Linear guideway product specifications	21
5.1	Type R and RD	21
5.2	Type RN	31
5.3	Type RNG	37
5.4	Type N/O	45
5.5	Type M/V	53
6	Recirculating unit product specifications	62
6.1	Type SK and SKD	62
6.2	Type SKC	65
6.3	Type SR	68
6.4	Type NRT (with NRV)	71
7	Options for linear guideways	75
7.1	Quality classes (SQ and SSQ)	75
7.2	Guideways made of corrosion-resistant steel	75
7.3	Run-ins rounded	76
7.4	Multi-part linear guideways	76
7.5	Height-matched guideways	77
7.6	DURALLOY® coating	77
7.7	DryRunner coating	78
7.8	Cage control FORMULA-S	79
7.9	Cage control types N/O and M/V	80
7.10	Fixing holes	80
8	Options for recirculating units	85
8.1	Matched recirculating units	85
8.2	Central lubricating system for NRT recirculating units	86

Table of contents

	Page number
9 Standard parameters for linear guideways	87
9.1 Quality classes	87
9.2 Tolerance of the supporting surface to the track	87
9.3 Length tolerances and distances between fixing holes	88
9.4 Operating temperatures	88
9.5 Speeds and accelerations	88
9.6 Friction, running accuracy and smoothness	88
10 Standard parameters for recirculating units	89
10.1 Operating temperatures	89
10.2 Speeds and accelerations	89
10.3 Friction, running accuracy and smoothness	89
11 Design	90
11.1 Linear guideways	90
11.2 Recirculating units	93
12 Load carrying capacity and service life	95
12.1 Basic principles	95
12.2 Short strokes	96
12.3 Calculating service life	97
12.4 Example calculations	102
12.5 Elastic deformation and rigidity of linear bearings	111
12.6 Elastic deformation and rigidity of recirculating units	113
13 Construction and installation guidelines	117
13.1 Connecting structure	117
13.2 Configuring the connecting structure	117
13.3 Installation methods	120
13.4 Fastening	124
13.5 Torque settings for fastening screws	125
13.6 Preloading	126
13.7 Sealing and covers	133
13.8 Lubrication	134
13.9 Transport, handling and storage	136
13.10 Assembly guidelines	136
14 Order descriptions	140

In 1923 SCHNEEBERGER laid the foundation of what is today global linear motion technology. SCHNEEBERGER standards then made it possible to build linear guideways, which in terms of loading capacity, reliability and cost-effectiveness set new standards and soon defined what is today the definitive industry standard.

The same principles that were the foundation for our success, informing our way of thinking and acting apply today as previously: the spirit of innovation, a no-compromise approach to quality and the ambition to deliver to our customers products that are technically and economically superior again and again. Both then and today the name SCHNEEBERGER throughout the world is synonymous with modern linear guide technology. Our core competencies, development, production and application know-how make us a well respected business partner. Together with our committed, customer-oriented and unique employees, we are global leaders.

We have developed a broad and deep expert knowledge from many successful projects in a variety of industries. Together with customers we evaluate the best products from the standard range or define project-specific solutions. Thanks to many years of experience and consistent focus on linear motion technology, we have been able to continuously develop our products and solutions and so provide our customers with technical advantages.

State-of-the-art production technologies and highly specialised employees are responsible for the highest possible quality standards. Our production is subject to stringent specifications and tests.

Our high-precision products are suitable for use in a variety of fields of application:

- Biotechnology
- Semiconductor industry
- Laboratory automation
- Medical technology
- Pick and place machines
- Measuring technology
- Micro-automation
- Nanotechnology
- Surface finishing
- Optics industry
- Processing machines for the micro-sector

Our linear guideways and recirculating units are available in many designs, sizes and standard lengths and depending on the specific application can be equipped with balls, rollers or needles.

The use of SCHNEEBERGER linear guideways and recirculating units makes it possible to build cost-effective linear guideway systems. The strengths of our products:

- High level of smoothness and consistent accuracy
- No stick-slip effect
- Rapid travelling speeds
- Minimal wear
- High level of reliability
- High rigidity
- High load carrying capacity
- Used in vacuum and clean room

Our skilled and committed employees will be pleased to advise you at any time on how to develop your applications.

2 Useful guidelines

2.1 2D- and 3D-drawings

Drawings and models are available on the Cadenas Part Server free of charge in all formats.

The required download area with additional product information can be found on the web site www.schneeberger.com.

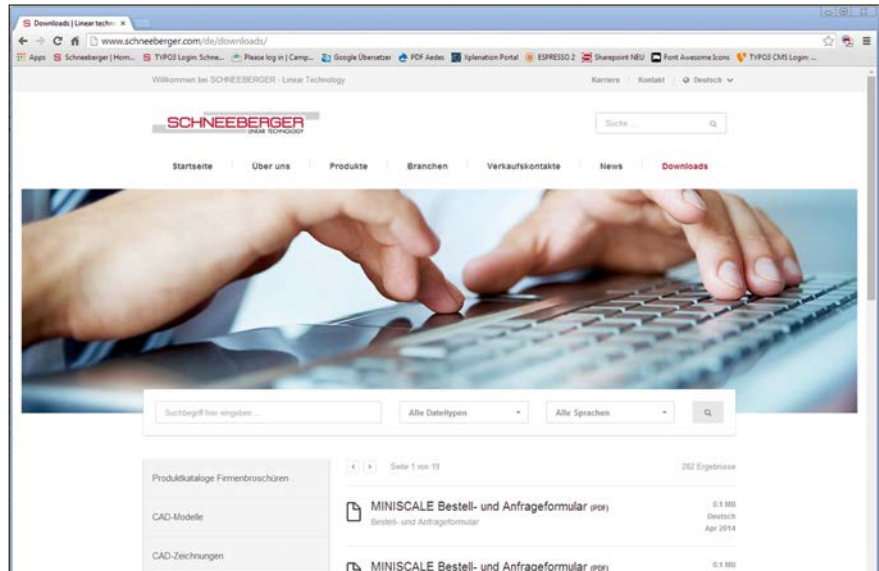

Our website www.schneeberger.com

2.2 Regulations governing substances and limit values

The products presented in this catalogue do not include any forbidden substances based on the RoHs guidelines and do not release chemical substances in accordance with the REACH guidelines.

2 Useful guidelines

2.3 Index and type designations

A	Chapter
A rail	3.3
AA-RF	5.1
AC	5.1
Accelerations	5 / 6 / 9.5 / 10.2
Accuracy and accuracy classes	7.1 / 9.2
AK	5.1
Angular error	13.2
Application-specific solutions	3.5
Assembly guidelines	13.9
B	
B rail	3.3
C	
C rail	3.3
Cage	5
Cage length	11.1
Cage control	5.2 / 5.3 / 7.8 / 7.9
Centralised lubricating system	8.2 / 13.7
Chemical substances	2.2
Coating	7.6 / 7.7
Connecting structure	13.1 / 13.2
Cover	13.6
Correction factor	12.3
Corrosion-resistant steel	7.2
Customer-specific design	3.5
D	
Design	11
Design guidelines	13
D hole	7.10
D rail	3.3
Double V-shaped guide	5.1
DR	7.7
Drawings (2D and 3D)	2.1
DRC1	7.7
Dry run	7.7
Dry Runner	7.7
DU	7.6
DURALLOY®	7.6
Dynamically equivalent load	12.3
E	
EAM	5.5
Earlier generations of the product	3.3
EAV	5.5
EE	5.1
Effective load carrying capacity	12.3
EG	7.3
Elastic deformation	12.5
EM	5.5

2 Useful guidelines

E	Chapter
Emergency running characteristic	7.6
Enclosed configuration	13.3
End pieces	5
End screws	5
E rail	3.3
EV	5.5
Event probability	12.3
Example calculations	12.4
Examples of use	4
F	
Fastening	13.4
Fastening screws with thin shaft	5.1 / 5.2 / 5.3 / 5.4
Fixing holes	5 / 6 / 7.10 / 9.3
FORMULA-S	5.2 / 5.3 / 7.8
Friction	9.6 / 10.3
G	
GA	5.1 / 5.2
GAN	5.2
GB	5.1
GBN	5.3
GC	5.1
GC-A	5.1
GCN	5.3
GCN-A	5.3
GD	5.1 / 5.2 / 5.4
GDN	5.3
GFN	5.4
GFO	5.4
GH	5.4
GH-A	5.4
G hole	7.10
GP	8.1
GW	5.4
GW-A	5.4
H / I / J	
HA	7.5
Handling	13.8
Hardness	5 / 6
Hardness factor	12.3
Height-matched linear guideways	7.5
Height offset	13.2
Hole types	5 / 6 / 7.10
Stroke	11.1
HW	5.4 / 5.5
Installation methods	13.3
Installation guidelines	13
J/K	3.3

2 Useful guidelines

K	Chapter
KBN	5.2 / 5.3
KBS	5.2 / 5.3
KS	5.2 / 5.3 / 7.8
KZST	5.4 / 5.5 / 7.9
L	
Linear guideways ground together	7.4
L/M	3.3
Load carrying capacity	12
Loading capacity	5 / 6 / 12
Locating surface	7.1 / 13.1 / 13.2
Lubrication	12.2 / 13.7
Lubricating stroke	12.2
M	
Matched recirculating units	8.1
Materials	5 / 6
Multi-part linear guideways	7.4
Moment loads	5 / 6
M/V	3.1 / 5.5
N	
N/O	3.1 / 5.4
Normal quality	7.1
NQ	7.1
NRT	3.2 / 6.4
NRV	3.2 / 6.4
Number of rolling elements	11.1
O	
Open configuration	13.3
Operating temperatures	5 / 6 / 9.4 / 10.1
Options	7 / 8
Order descriptions	14
Oscillating motion	12.2
Overrunning cage	5 / 11.1
Overview of products	3
P / Q	
Parallelism tolerances	7.1
Part Server	2.1
Preload	13.5
Preload wedge	6.4
Product specifications	5 / 6
Product overview	3
Quality classes	7.1
R	
Ra value	13.2
RD	3.1 / 5.1
REACH	2.2
Recirculating unit	3.2 / 6 / 11.2
RF	7.2
Rigidity	12.5

2 Useful guidelines

R	Chapter
R linear guideway	3.1 / 5.1
RN	3.1 / 5.2
RNG	3.1 / 5.3
RoHS	2.2
Run-ins rounded	7.3
S	
Seal	13.6
Sealing rings	13.7
Service life	12.1 / 12.2 / 12.3 / 13.1
Short stroke	12.2
SHW	5.4 / 5.5
SK	3.2 / 6.1
SKC	3.2 / 6.2
SKD	3.2 / 6.1
Sliding guideway	3.4
Spacings between fixing holes	9.3
Speeds	5 / 6 / 9.5 / 10.2
Special versions	7 / 8
SQ	7.1
SR	3.2 / 6.3
SSQ	7.1
Standard parameter	9 / 10
Storage	13.8
Subsequent lubrication	13.7
Supporting surface	7.1 / 9.2 / 13.2
Surface quality	13.2
T	
Temperatures	5 / 6 / 9.4 / 10.1
Temperature factor	12.3
Tolerance of the supporting surface to the track	9.2
Torque settings for adjusting screws	13.5
Torque settings for fastening screws	13.5
Transport	13.8
U / V / W / X / Z	
Units	2.4
Vacuum suitability	5.1 / 5.2 / 5.3 / 6.2 / 7.6 / 7.7 / 7.8
V hole	7.10
Web site	2.1
Wipers	5.1 / 5.3 / 5.4 / 5.5 / 6.1 / 6.2 / 6.4
W/Z	3.3
ZG	7.4
ZS	8.2

2 Useful guidelines

2.4 Description of the units

Name	Description	Unit
a	Event probability	Factor
C	Dynamic loading capacity for a 100'000 m travel distance	N
C ₀	Static loading capacity	N
C ₁₀₀	Dynamic loading capacity for a 100'000 m travel distance	N
C ₅₀	Dynamic loading capacity for a 50'000 m travel distance	N
C _{eff}	Effective load carrying capacity per rolling element	N
D _w	Diameter of the rolling element	mm
F	Operating load, load of the linear guideway	N
F _{1... F_{2...}}	Individual loads	N
f _h	Hardness factor	Factor
f _t	Temperature factor	Factor
H	Stroke	mm
K	Cage length	mm
K _t	Load-bearing (cage) length	mm
L	Length	mm
L	Nominal service life	m
L _{1 ... L_{2 ...}}	Partial travel distance	mm
M	Moment load longitudinally and laterally	Nm
M _{ds}	Tightening torque	Ncm
M _L	Permissible moment load longitudinally and laterally	Nm
M _Q	Permissible moment load transversely	Nm
P	Dynamically equivalent load	N
P _L	Dynamically equivalent load longitudinally	N
P _Q	Dynamically equivalent load transversely	N
P _{vs}	Infeed force	N
Q	Medium linear guideway distance	mm
R _A	Number of rolling elements	Item
R _T	Number of load-bearing rolling elements	Item
R _{Tmin}	Correction factor	Factor
t	Cage division	mm
t ₂	Length of the middle section	mm
w	Distance Cage start to the middle of the first rolling element	mm
δ _S	Deformation of the connecting structure	µm
δ _A	Deformation of the rolling element including the guide rail	µm

3 Overview of product



Linear guideway type R



Linear guideway type RD



Linear guideway type RN



Linear guideway type RNG



Linear guideway type N/O



Linear guideway type M/V



Recirculating unit type SK



Recirculating unit type SKD



Recirculating unit type SKC



Recirculating unit type SR



Recirculating unit type NRT



Preload wedge NRV

3 Overview of product

3.1 An overview of linear guideways

The SCHNEEBERGER range of linear guideways offers you perfect solutions for your specific applications.



	R	RD	RN	RNG	N/O	M/V
For features and dimension table, see chapter	5.1	5.1	5.2	5.3	5.4	5.5

Assessment of the advantages

Parameter: displacement force & high level of smoothness

- balls	++++	++++				
- rollers	+++	+++	+++	+++		
- needles					++	++

Parameter: High loading capacity

- balls	+	+				
- rollers	++	++	+++	+++		
- needles					++++	++++

Legend:

- ++++ best choice
- +++
- ++
- + good choice

Performance parameters

Maximum acceleration in m/s ²	50	50	50	50	50	50
Maximum acceleration with cage control in m/s ²	Not available	Not available	300	300	200	200
Maximum speed in m/s	1	1	1	1	1	1
Maximum speed with cage control in m/s	Not available	Not available	1	1	1	1
Quality classes	see chapter 9.1	see chapter 9.1	see chapter 9.1	see chapter 9.1	see chapter 9.1	see chapter 9.1
Operating temperature in degrees Celsius	-40° C – +80° C	-40° C – +80° C	-40° C – +80° C	-40° C – +80° C	-40° C – +80° C	-40° C – +80° C

Material (standard)







Rail made of tool steel, hardness in HRC	58 - 62	58 - 62	58 - 62	58 - 62	58 - 62	58 - 62
Rolling element made of tool steel, hardness in HRC	58 - 64	58 - 64	58 - 64	58 - 64	58 - 64	58 - 64

Material (corrosion-resistant)

Rail made of tool steel, hardness in HRC	min. 54	min. 54	min. 54	min. 54	min. 54	min. 54
Rolling element made of tool steel, hardness in HRC	min. 56	min. 56	min. 56	min. 56	min. 56	min. 56

3 Overview of product

The following special versions do not apply in respect of every rail cross-section or every rail length. For details and technical information, see chapter 7.

Special versions	Order code						
		R	RD	RN	RNG	N/O	M/V
Precision in special quality ⁽¹⁾	SQ	✓	✓	✓	✓	✓	✓
Precision in super special quality ⁽¹⁾	SSQ	✓	✓	✓	✓	✓	✓
Linear guideways made of corrosion-resistant steel ⁽²⁾	RF	✓	✓	✓	✓	✓	✓
Run-ins rounded	EG	✓	✓	✓	✓	✓	✓
Prepared for roller cage type EE	EE	✓	✓	---	---	---	---
Multi-part linear guideways	ZG	✓	✓	✓	✓	✓	✓
Pair of height-matched guideways	HA	✓	✓	✓	✓	✓	✓
DURALLOY® coating ⁽³⁾	DU	✓	✓	✓	✓	✓	✓
DryRunner coating ⁽⁴⁾	DR	---	---	✓	✓	---	---
Cage control FORMULA-S	KS	---	---	✓	✓	---	---
Cage control	KZST	---	---	---	---	✓	✓
Various versions of fixing holes	V, G, D	✓	✓	✓	✓	✓	✓

(1) There are limitations relating to:

- corrosion-resistant steel
- coatings
- maximum rail length

(2) There are limitations relating to:

- Maximum rail length (in normal quality as well as in options SQ and SSQ)
- Hardness of the steel. This is reduced to a min. 54 HRC, which affects the service life of the linear guideway

(3) - The special versions ZG and SSQ are not possible

- Special quality (SQ) only on request

(4) - DryRunner® supports operating without a lubricant. Due to increased cage creep we recommend the additional use of the option «cage control FORMULA-S»

- Options ZG and SSQ cannot be supplied. Option SQ on request
- There are limitations concerning maximum rail length
- This option is not available for the sizes RN/RNG 9 and RN/RNG 12

3 Overview of product

3.2 An overview of recirculating units

The SCHNEEBERGER range of recirculating units offers you perfect solutions for your specific applications



	SK	SKD	SKC	SR	NRT
For features and dimension table, see chapter 6	6.1	6.1	6.2	6.3	6.4

Assessment of the advantages

Parameter: Low displacement force & high level of smoothness

- balls	+++	++++	++++		
- rollers				++	++

Parameter: High loading capacity

- balls	++	++	+		
- rollers				+++	++++

Legend:

- ++++ best choice
- +++
- ++
- + good choice

Performance parameters

Max. acceleration in m/s ²	50	50	50	50	50
Max. speed in m/s	2	2	2	2	1
Operating temperature in degrees Celsius	-40° C – +80° C	-40° C – +80° C	-150° C to +200° C	-40° C – +80° C	-40° C – +80° C

Material (standard)

Supporting structure of tool steel, hardness in HRC	58 - 62	58 - 62	58 - 62 coated	58 - 62	58 - 62
Rolling element made of tool steel, hardness in HRC	58 - 64	58 - 64 (Damping elements made of plastic)	---	58 - 64	58 - 64
Rolling element made of ceramic (Balls made of Teflon® are situated between the ceramic balls)	---	---	✓	---	---
Redirection unit	Size 1, 2, 9 and 12 made of anodized aluminium Sizes 3 and 6 depending on the length made of plastic or aluminium	Depending on the length made of plastic or aluminium	tool steel, coated	Depending on the length made of plastic or aluminium	Plastic

Special versions

Detailed technical information on the options listed below can be found in chapter 8

	Order code	SK	SKD	SKC	SR	NRT
Matched (height-matched)	GP	✓	✓	✓	✓	✓
Connection for centralised lubrication	ZS	---	---	---	---	✓

3 Overview of product

3.3 Earlier generations of the product

Examples of earlier generations of the product, which we are also pleased to manufacture for you today:



Linear guideway type W/Z



Linear guideway type L/M or J/K



Linear guideway type A



Linear guideway type B



Linear guideway type C



Linear guideway type D



Linear guideway type E

3 Overview of product

3.4 Slideways

In some applications slideways/slide bearings are more suitable than roller-contact bearings. For such applications SCHNEEBERGER produces steel strips, which are produced with a slideway lining selected by the customer (e.g. Turcite B, Glycodur or Ampco) and then re-ground.

The slideways can be supplied in standardised dimensions for the roller-contact bearing or on a customer-specific basis too.

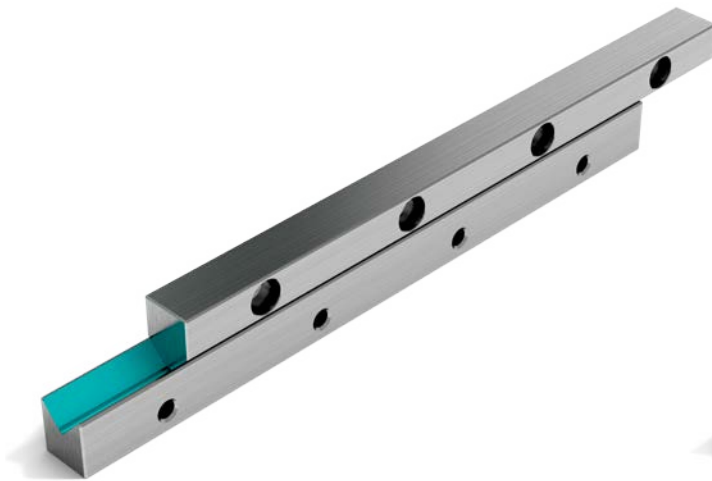

Slideways

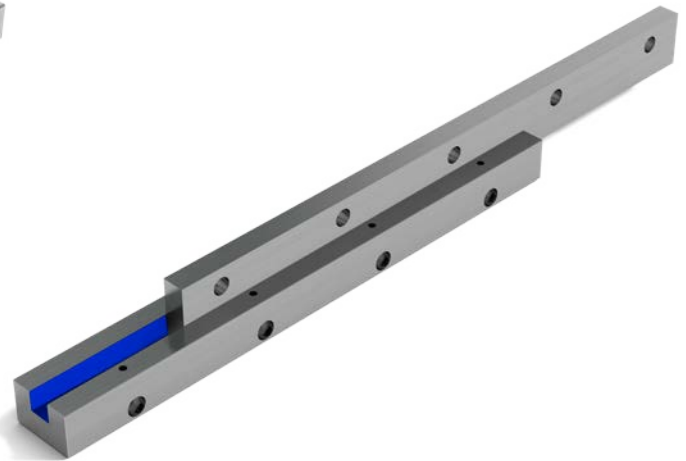

Flat strips

3.5 Application-specific solutions



Our linear guideways can be universally deployed, but can also be configured on a customer-specific basis ex works. Amongst other things, SCHNEEBERGER offers the following services:

- modified standard
- customer-specific design
- special greasing (cleanroom, vacuum, extraordinary temperature ranges, etc.)
- special packaging

4 Applications

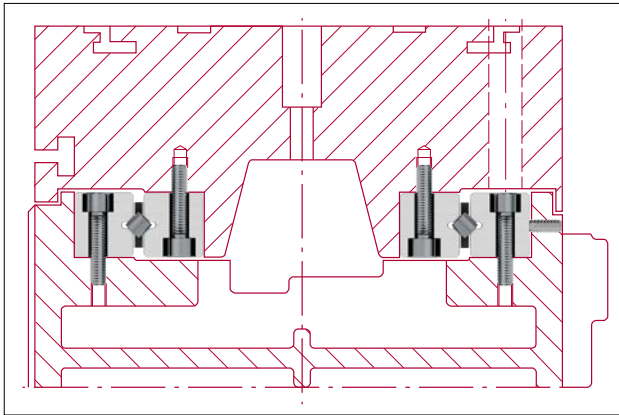

Linear guideway for a tool grinding machine table

Precision-grinding on tool grinding machines requires a stick-slip-free and frictionless guideway to allow longitudinal movement of the table.

Possible SCHNEEBERGER products:

- 4 linear guideways type R 9-800
- 2 roller cages AC 9 x 33 rollers
- 8 end pieces GA 9, GB 9

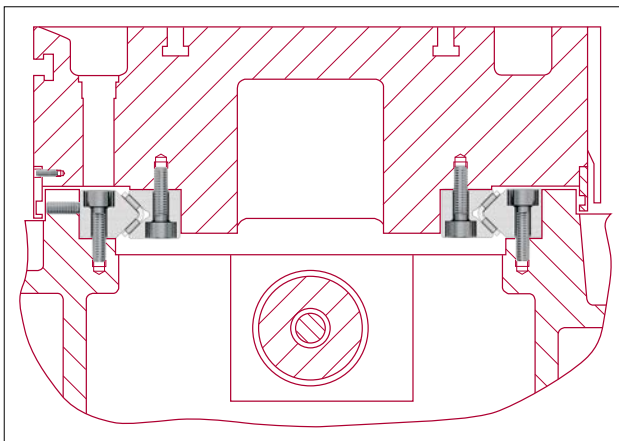

Table bearing for an internal cylindrical grinding machine

Internal cylindrical grinding robots require absolutely zero-backlash table guiding in order to meet the stringent requirements of today's grinding technology.

The grinding table displayed is mounted with type N/O linear guideways whose V-shaped needle cages are connected to an oil impulse lubrication system. This creates the conditions needed to control high table speeds with minimal force applied.

Possible SCHNEEBERGER products:

- 2 linear guideways type O 2535-1000
- 2 linear guideways type N 2535-1000
- 2 needle cages HW 20 x 725
- 4 end pieces GH 2535 without wipers

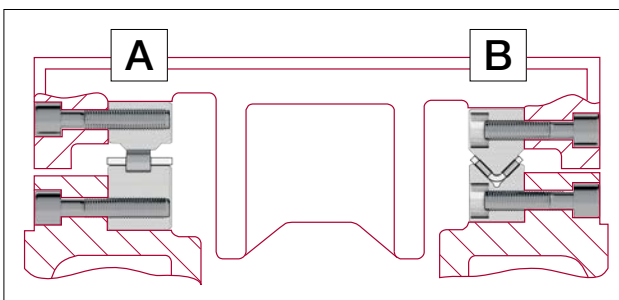

Open configuration (floating bearings) for heavy surface grinding machine

Surface-mounted roller guides then come into play particularly when large and heavy workpieces are being machined. The weights of table and workpiece and the grinding pressure have a vertical action on the roller guides.

Cost-effectiveness, simple assembly and a high level of running accuracy characterise this configuration. Expansion of the table resulting from the effect of heat without limitations is also prevented thanks to characterize expansion options.

Its construction is simple and cost-effective. The N/O linear guideway assumes the task of being the lateral linear guideway for the table. As the surface guideway is adjusted level with the N/O, the linear guideway systems can be interchanged - depending on whether the grinding spindle is mounted to the right or left.

Possible SCHNEEBERGER products:

- A**
- 1 linear guideway spec. 45 x 35 x 600-EG *
 - 1 linear guideway spec. 45 x 42.5 x 1'000
 - 1 roller cage H 25 x 810 mm
 - 2 end pieces special

* Run-ins rounded

- B**
- 1 linear guideway type N 3555-600-EG *
 - 1 linear guideway type O 3555-1000
 - 1 needle cage SHW 30 x 810 mm
 - 2 end pieces GW 3555

* Run-ins rounded

4 Applications

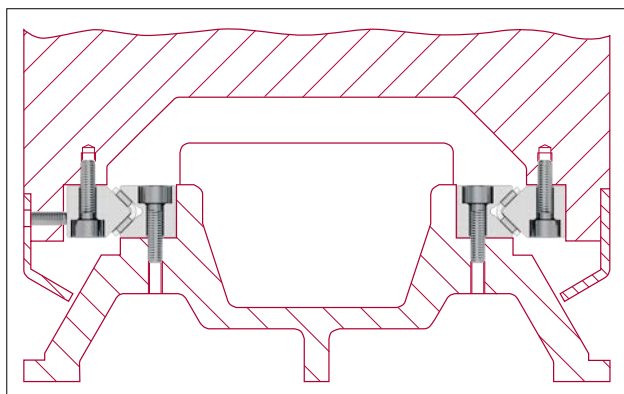

Possible SCHNEEBERGER products:

- 2 linear guideways N 3045-900
- 2 linear guideways O 3045-900
- 2 needle cages SHW 25 x730 mm
- 8 end pieces GF 3045

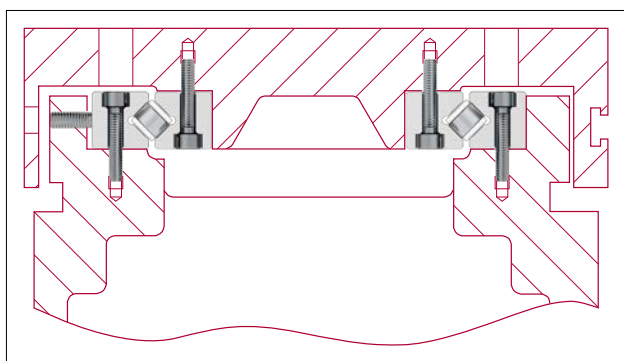

Possible SCHNEEBERGER products:

- 2 linear guideways RNG 9-700
- 2 linear guideways RNG 9-450-EG *
- 2 roller cages KBN 9 x 43 rollers
- 4 end pieces GCN 9

* Run-ins rounded

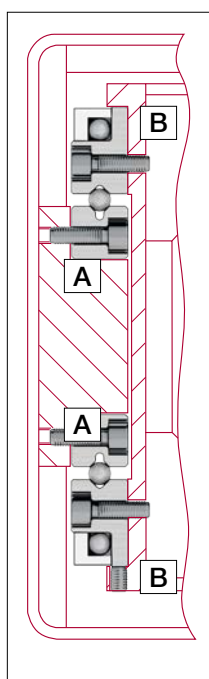

Closed V guideway for surface grinding machines

Economic perspectives also determine the structural design of the tables guideways for surface grinding machines. The V-shaped arrangement of the roller guideways creates a closed linear guideway that can be loaded for forces and moments from all directions.

The few components ensure rapid and simple assembly. The stroke and table length ratios are optimal for the use of roller guideways. The basic surfaces of the roof-shaped linear guideways can be machined with extreme efficiency and precision because they are on the same plane. These surfaces also form the basis for achieving high levels of running accuracy.

V guideway for heavy tool grinding machines

Tool grinding machines place very high demands on the roller guideway system of the machine table. High level of running accuracy, minimal friction, no stick-slip effect and protected arrangement of the roller guideways are the most important requirements.

The RNG roller guideways used here are ideally suited to this task thanks to their high load carrying capacity. The table construction allows drive mechanisms to be accommodated; the upper part of the table can also be installed with great ease. The preload of the linear guideway system can also be easily set subsequently.

Infeed device

The infeed device working in vacuum places high demands on the linear guideway system. A U-shaped support forms the supporting element and also acts as the take-up for the linear guideways. The whole system is made of a non-corrosive material and works vertically with a stroke of 2'700 mm.

Linear guideways, which are assembled in the U-shaped basic component, and 4 type SK rolling elements form the actual guide system. Two of the four rolling elements can be adjusted externally and so support optimal preload setting. All individual components of the rolling elements are made out of stainless steel or aluminium.

Possible SCHNEEBERGER products:

- A** 4 linear guideways R 9-1400-RF*-ZG**
- B** 4 recirculating units SK 9-150-RF*

* non-corrosive

** multi-part linear guideways

4 Applications



Patient tables

Highly developed, automatic patient tables are used, amongst other things, in computer tomography (CT), magnetic resonance tomography (MRT) or radiotherapy.

All kinematic processes place the highest demands on the linear guideway systems in terms of running accuracy, smoothness, maintenance-free operation, rigidity, ease of installation and radiation resistance.

Possible SCHNEEBERGER products:

R 9 linear guideways



Microtome

Microtomes are cutting devices used to create wafer-thin sections. They are used for microscopic preparations (for example, biological tissue) or analysis of plastics.

Biological material is normally hardened before being cut by means of fixing and then made sliceable by means of «embedding», i.e. inclusion with a fluid substance such as paraffin or synthetic resin. The thickness of the slices is significantly smaller than the diameter of a human hair and is typically around 1 to 100 µm.

Due to these extraordinary requirements, the most stringent demands in terms of smoothness and precision are placed on the linear guideway systems.

Possible SCHNEEBERGER products:

RNG 4 linear guideways



4 Applications



Wire bonder

Wire bonding is the preferred method for making bonds between an integrated circuit (IC) and a printed circuit board. Wire bonding generally represents the most cost-effective and flexible bonding technology with which the thinnest wires are used for bonding electrical connections.

Aluminium, copper or gold wire from 15 μm in diameter is usually used for this technology. The requirements in respect of the linear guideway system for a wire bonder are correspondingly stringent.

- The highest precision and rigidity
- The highest speeds
- The highest level of smoothness
- The highest level of reliability.

Possible SCHNEEBERGER products:

SCHNEEBERGER supplies prestigious manufacturers of wire bonders with customer-specific linear guideway systems.

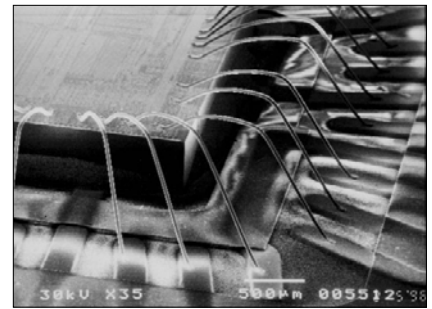

Aluminium wires with a diameter of 25 μm bond the electrodes of microchip with the conductor tracks of a carrier substrate.

Large-scale machining center

To ensure that it is possible to manufacture with high precision under the most stringent loads, rigid and precise linear guideway systems are critical.

Possible SCHNEEBERGER products:

- A** MONORAIL MR 65
- B** recirculating unit NRT with preload wedge NRV

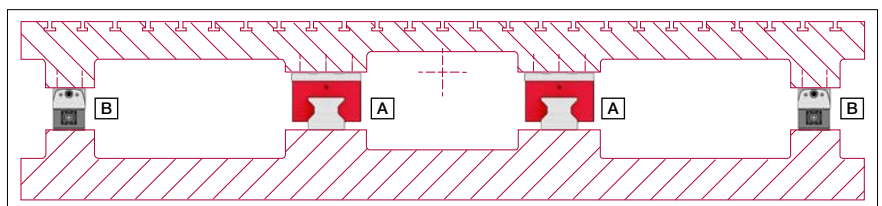
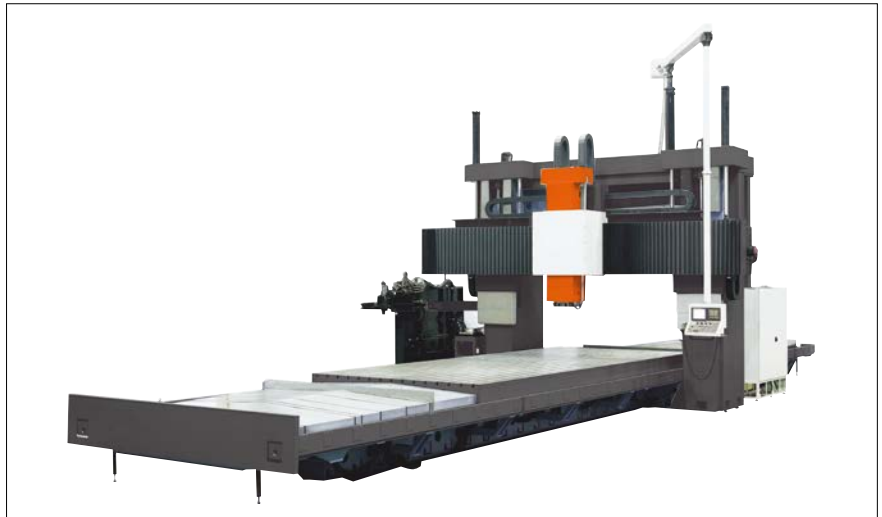

5 Product specifications

5.1 Type R and RD



Type R with balls

Type R with rollers

Type RD

With its type R, SCHNEEBERGER has developed the first standardized cross roller guide, which has defined the global industry standard.

The RD double V-shaped guide supplements the R linear guideway and supports space-saving and cost-effective solutions.

Type R benchmark data

Track and surface quality

- Finely ground supporting and/or locating surfaces and tracks (90° V-profile)

Materials (standard)

- Rails from through hardened tool steel 1.2842, hardness 58 – 62 HRC
The sizes R/RD 1 and 2 are made out of tool steel 1.3505
- For non-corrosive guideways tool steel 1.4034 and 1.4112 is used
- Rolling element made of through hardened roller bearing steel, hardness 58 – 64 HRC

Rolling element

- Ball or roller

Speed

- 1 m/s

Acceleration

- 50 m/s²

Accuracy

- R and RD linear guideways are available in three quality classes (see chapter 9)

Operating temperatures

- -40° C to +80° C

The R and RD design can be combined with the following products:

- recirculating unit type SK, SKC and SR

5 Linear guideways

Dimensions and load capacities type R

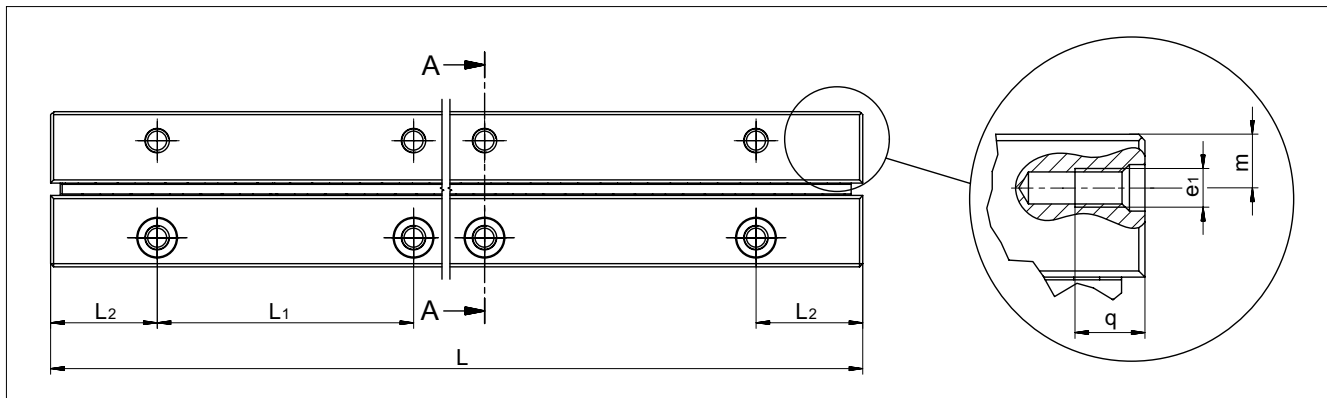

Type	Size	L in mm*	Weight in g	A	B	Dw	J	L ₁	L ₂	N	d	e	e ₁	f	g	m	q	Options (see chapter 7)	Accessories
				mm															
R	1	20	3	8.5	4	1.5	3.9	10	5	1.8	3	M2	M1.7	1.65	2.6	1.9	2.5	SQ SSQ RF EG ZG HA DU	Cage: - AA-RF 1 - AC 1 - AK 1 End screw: - GA 1 End piece: - GB 1
		30	4																
		40	5																
		50	6																
		60	7																
		70	8																
		80	9																
		100	12																
120	14																		
R	2	30	8	12	6	2	5.5	15	7.5	2.5	4.4	M3	M2.5	2.55	4	2.7	3.5	SQ SSQ RF EG ZG HA DU	Cage: - AA-RF 2 - AC 2 - AK 2 End screw: - GA 2 End piece: - GB 2
		45	11																
		60	14																
		75	17																
		90	20																
		105	23																
		120	26																
		150	34																
180	40																		
R	3	50	23	18	8	3	8.3	25	12.5	3.5	6	M4	M3	3.3	4.8	4.1	7	SQ SSQ RF EG ZG HA DU	Cage: - AA-RF 3 - AC 3 - AK 3 End pieces: - GB 3 - GC 3 - GC-A 3 End screw: - GA 3 Fastening screw - GD 6
		75	34																
		100	45																
		125	56																
		150	67																
		175	78																
		200	89																
		225	100																
		250	111																
		275	122																
		300	133																
		350	156																
		400	178																
500	222																		
600	267																		

* The lengths shown are standard; other lengths can of course be delivered. The maximum lengths are listed on page 26.

5 Linear guideways

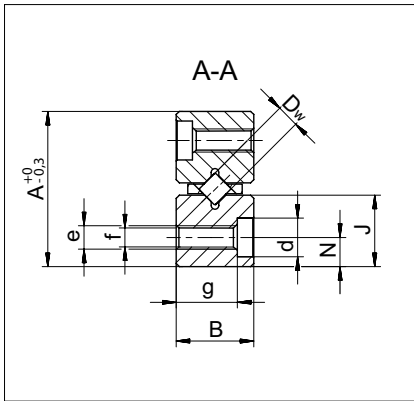

Type	Size	L in mm*	Weight in g	A	B	Dw	J	L ₁	L ₂	N	d	e	e ₁	f	g	m	q	Options (see chapter 7)	Accessories
				mm															
R	6	100	145	31	15	6	13.9	50	25	6	9.5	M6	M5	5.2	9.8	6.9	9	SQ SSQ RF EG EE ZG HA DU	Cage: - AA-RF 6 - AC 6 - AK 6 - EE 6 End pieces - GB 6 - GC 6 - GC-A 6 End screw: - GA 6 Fastening screw - GD 6
		150	220																
		200	295																
		250	370																
		300	445																
		350	520																
		400	595																
		450	670																
		500	745																
		600	895																
		700	1'045																
800	1'195																		
1'000	1'500																		
R	9	200	630	44	22	9	19.7	100	50	9	10.5	M8	M6	6.8	15.8	9.8	9	SQ SSQ RF EG EE ZG HA DU	Cage: - AC 9 - AK 9 - EE 9 End pieces - GB 9 - GC 9 - GC-A 9 End screw: - GA 9 Fastening screw - GD 9
		300	945																
		400	1'260																
		500	1'575																
		600	1'890																
		700	2'205																
		800	2'520																
		900	2'835																
		1'000	3'150																
		1'100	3'465																
		1'200	3'780																
1'400	4'410																		
R	12	200	1'040	58	28	12	25.9	100	50	12	13.5	M10	M8	8.5	19.8	12.9	12	SQ SSQ RF EG ZG HA DU	Cage: - AC 12 - AK 12 End pieces: - GB 12 - GC 12 - GC-A 12 End screw: - GA 12 Fastening screw: - GD 12
		300	1'560																
		400	2'090																
		500	2'615																
		600	3'140																
		700	3'665																
		800	4'190																
		900	4'715																
		1'000	5'240																
		1'100	5'765																
		1'200	6'290																

* The lengths shown are standard; other lengths can of course be delivered. The maximum lengths are listed on page 26.

5 Linear guideways

Dimensions and load capacities of type RD

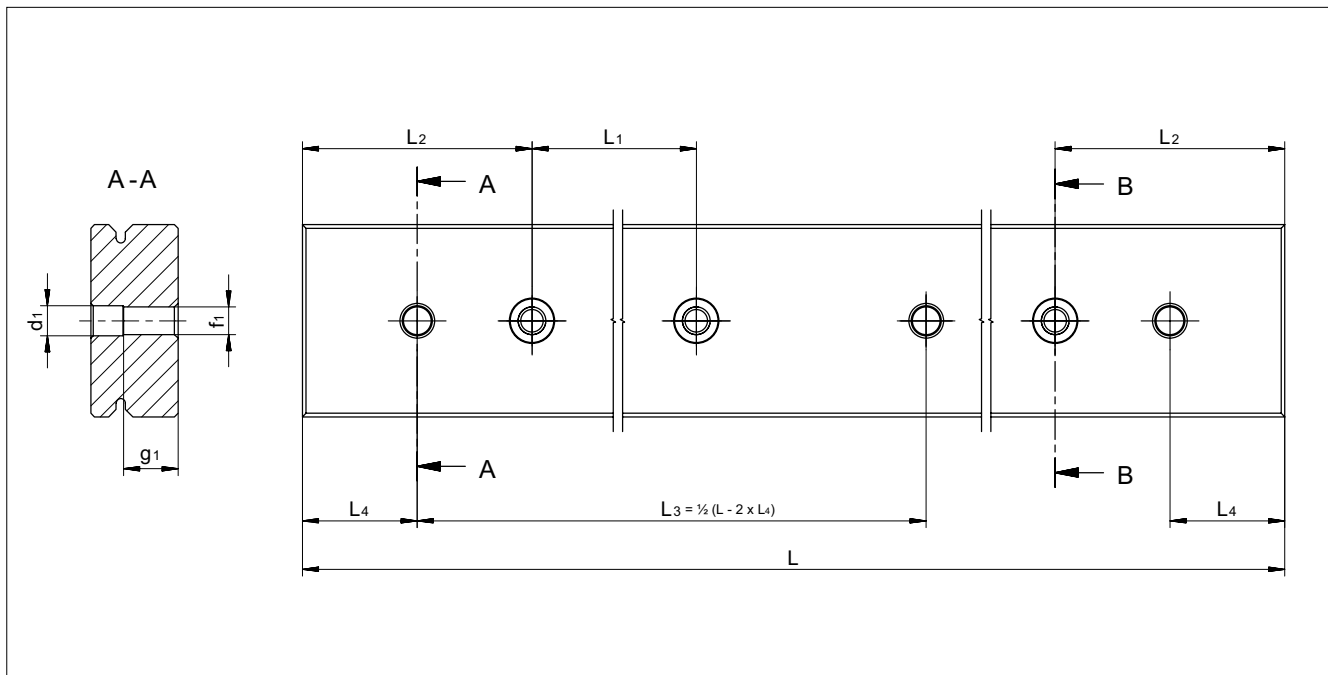

Type	Size	L in mm*	Weight in g	A	B	B ₁	B ₂	Dw	J	L ₁	L ₂	L ₄	Q	d	d ₁	e	f	f ₁	g	g ₁	k	Options (see chapter 7)	Accessories
				mm																			
RD	1	100	50	22	4	5.5	6	1.5	12.8	25	12.5	**	13.5	4.4	-	M3	2.55	**	3.5	-	2	SQ SSQ RF EG ZG DU	Cage: - AA-RF 1 - AC 1 - AK 1
		150	70																				
		200	100																				
RD	2	200	220	30	6	8.5	9	2	17	50	25	**	18	6	-	M4	3.35	**	5.4	-	3	SQ SSQ RF EG ZG DU	Cage: - AA-RF 2 - AC 2 - AK 2
		300	320																				
		400	430																				
RD	3	300	690	46	8	11.5	12	3	26.6	50	25	**	28	7.5	**	M5	4.2	**	7.3	**	4	SQ SSQ RF EG ZG DU	Cage: - AA-RF 3 - AC 3 - AK 3
		400	920																				
		500	1'150																				
		600	1'380																				
		800	1'840																				

* The lengths shown are standard; other lengths can of course be delivered. The maximum lengths are listed on page 26.

** Positioning hole option available based on customer drawing (NZ).

5 Linear guideways

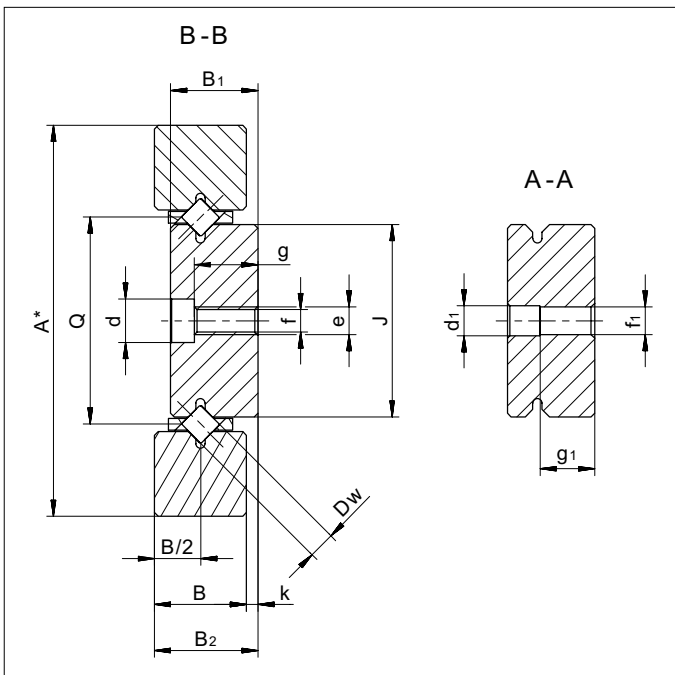

* with linear guideways type R

Type	Size	L in mm	Weight in g	A	B	B ₁	B ₂	D _w	J	L ₁	L ₂	L ₄	Q	d	d ₁	e	f	f ₁	g	g ₁	k	Options (see chapter 7)	Accessories
				mm																			
RD	6	On request	On request	76	15	19	20	6	41.8	100	50	**	45	9.5	**	M6	5.2	**	13.8	**	5	SQ SSQ RF EG EE ZG DU	Cage: - AA-RF 6 - AC 6 - AK 6 - EE 6
RD	9	Max. 3000	On request	116	22	27	28	9	67.4	100	50	25	72	10.5	8.5	M8	6.8	8 H7	20.8	16	6	SQ SSQ RF EG EE ZG DU	Cage: - AC 9 - AK 9 - EE 9
RD	12	Max. 3000	On request	135	28	34	35	12	70.8	100	50	25	77	13.5	10.5	M10	8.5	10 H7	25.8	20	7	SQ SSQ RF EG ZG DU	Cage: - AC 12 - AK 12

** Positioning hole option available based on customer drawing (NZ).

5 Linear guideways

Maximum lengths for type R

Type / Size	Quality class	Max. lengths in standard material (in mm)	Max lengths in non-corrosive material (in mm)
R 1	NQ	200	150
	SQ		
	SSQ	120	120
R 2	NQ	300	300
	SQ	300	300
	SSQ	180	180
R 3	NQ	800	600
	SQ		
	SSQ	600	
R 6	NQ	1500	1400
	SQ		1200
	SSQ	1200	900
R 9	NQ	3000	3000
	SQ		
	SSQ		
R 12	NQ	3000	3000
	SQ		
	SSQ		

Maximum lengths for type RD

Type / Size	Quality class	Max. lengths in standard material (in mm)	Max lengths in non-corrosive material (in mm)
RD 1	NQ	300	300
	SQ		
	SSQ		
RD 2	NQ	500	500
	SQ		
	SSQ		
RD 3	NQ	1200	600
	SQ		
	SSQ		
RD 6	NQ	1500	900
	SQ		
	SSQ	1200	
RD 9	NQ	3000	3000
	SQ		
	SSQ		
RD 12	NQ	3000	3000
	SQ		
	SSQ		

Rail chamfer

The detail of the rail chamfer is shown in the chart below. Please note that the part number and company logo are marked opposite to the datum and supporting surfaces.

Type / Size	Rail chamfer of reference edges in mm
R 1	0.3 x 45°
R 2	0.3 x 45°
R 3	0.6 x 45°
R 6	0.8 x 45°
R 9	0.8 x 45°
R 12	1.0 x 45°

5 Linear guideways

Accessories for type R and RD

Roller cage type AC

Compatible with:

Linear guideway type R and RD,
Sizes 1 to 12

Design:

Rollers fixed in place

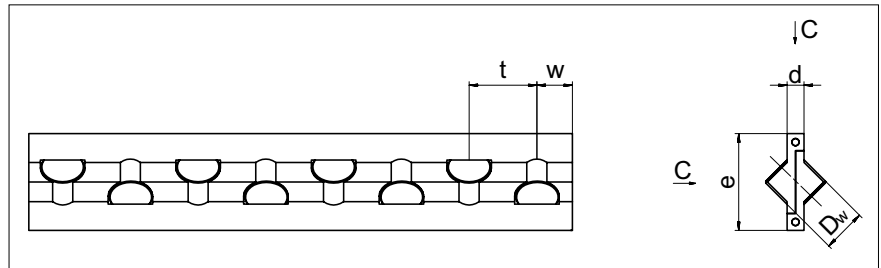

Installation method:

For normal application and certain
overrunning cage applications

Material:

Sizes 1, 2 POM
Size 3 PA GF 30%
As from size 6 PA GF 30%, plastic/steel
wire composite construction.
The wire is made out of stainless steel.

Type	Size	Dw	d	e	t	w	C per roller in N	max. length in mm
AC	1	1.5	0.45	3.5	3	approx. 1.5	50	80
	2	2	0.75	5	4	approx. 2	85	170
	3	3	1	7	5	approx. 2.5	130	1'200
	6	6	2.5	14	9	approx. 6	530	1'500
	9	9	3.5	20	14	approx. 9	1'300	1'500
	12	12	4.5	25	18	approx. 11	2'500	1'500

Option:

Corrosion-resistant rollers

Roller cage type AA-RF

Compatible with:

Linear guideway type R and RD,
Sizes 1, 2, 3 and 6

Design:

Rollers fixed in place

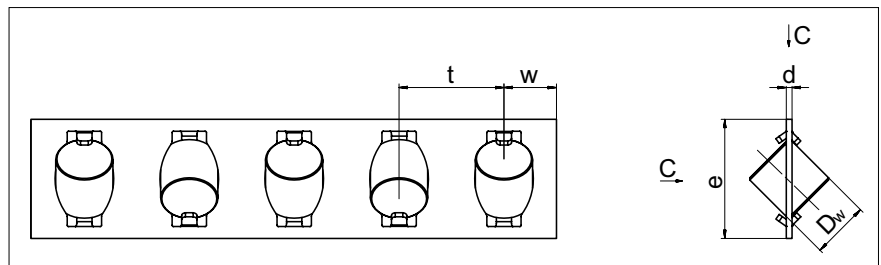

Installation method:

Not suitable as an overrunning cage

Material:

Cage and rollers made of corrosion-re-
sistant steel and thus also suitable for
use in vacuum

Type	Size	Dw	d	e	t	w	C* per roller in N	max. length in mm
AA-RF	1	1.5	0.2	3.8	3	approx. 1.5	44	90
	2	2	0.25	5.9	4	approx. 2	75	150
	3	3	0.3	7.5	5	approx. 2.5	115	350
	6	6	0.8	14	12	approx. 6	465	1'200

*The loading capacity C already includes the hardness factor f_H , as set out in chapter 12.3

5 Linear guideways

Accessories for type R and RD

Ball cage type AK

Compatible with:

Linear guideway type R and RD,
Sizes 1 to 12

Design:

Balls retained

Installation method:

For normal application and certain
overrunning cage applications

Material:

Sizes 1, 2 and 3 POM

As from size 65 PA GF 30%, plastic/
steel wire composite construction. The
wire is made out of stainless steel.

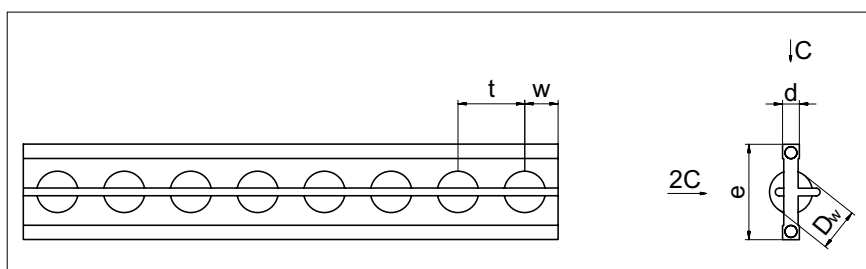

Type	Size	Dw	d	e	t	w	C per ball in N	max. length in mm
AK	1	1.5	0.45	3.5	2.2	approx. 1.5	9	80
	2	2	0.75	5	4	approx. 2	15	100
	3	3	1	7	4.2	approx. 2.5	25	180
	6	6	2.5	14	9	approx. 6	65	1'500
	9	9	3.5	20	14	approx. 9	150	1'500
	12	12	4.5	25	18	approx. 11	260	1'500

Roller cage type EE

Compatible with:

Linear guideway type R and RD,
Sizes 6 and 9

Design:

- The clearances of the guide rails are matched with the EE roller cage, which consequently works as a contaminant wiper. Displacement resistance is increased by the wiper function.
- Rollers fixed in place
- Only used with linear guideways with add-on designation EE
- Select end pieces of type GB or GC

Installation method:

Not suitable as an overrunning cage and
for freely surface-mounted guideways

Material:

PE

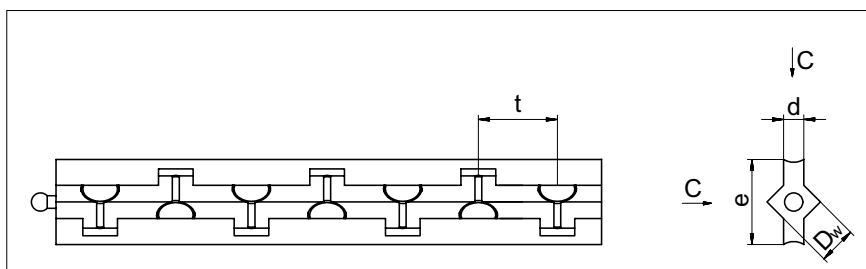

Type	Size	Dw	d	e	t	C per roller in N	max. length in mm
EE	6	6	3.2	13.5	12	530	1'500
	9	9	4.6	19	18	1'300	1'500

5 Linear guideways

Accessories for type R and RD

End screws type GA

Compatible with:

Linear guideway R 3 to R 12

Installation method:

For horizontal installation

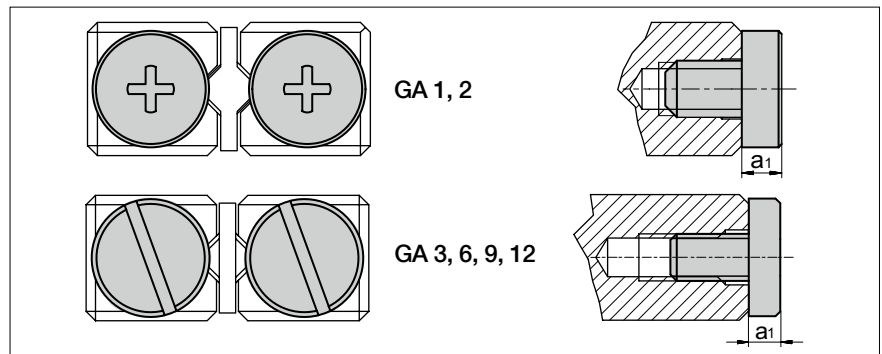

Size	GA 1	GA 2	GA 3	GA 6	GA 9	GA 12
a_1	1.2	1.8	2	3	3	3

End piece type GB 1

Compatible with:

Linear guideway R 1

Installation method:

No restrictions

Scope of supply:

Including fastening screws

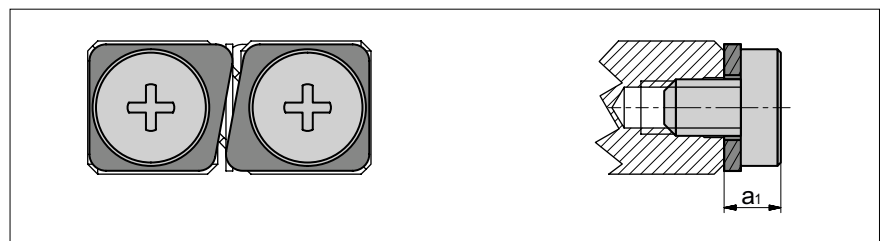

Size	GB 1
a_1	1.7

End piece type GB 2

Compatible with:

Linear guideway R 2

Installation method:

No restrictions

Scope of supply:

Including fastening screws

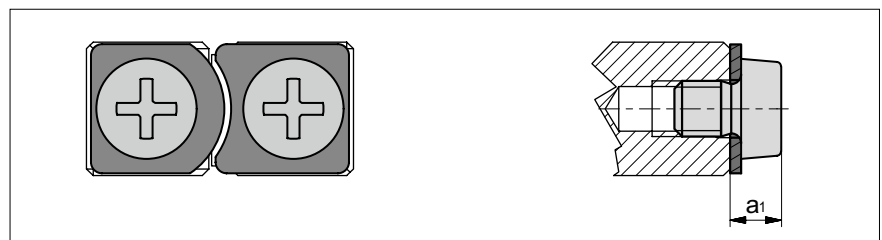

Size	GB 2
a_1	2

End piece type GB 3 to 12

Compatible with:

Linear guideway R 3 to R 12

Installation method:

No restrictions

Scope of supply:

Including fastening screws

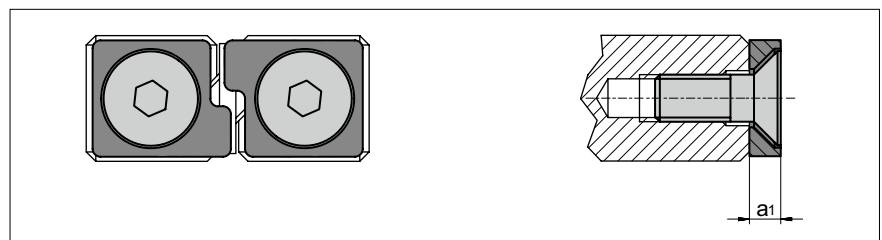

Size	GB 3	GB 6	GB 9	GB 12
a_1	2	3	4	5

5 Linear guideways

Accessories for type R and RD

End piece type GC

Compatible with:

Linear guideway R 3 to R 12

Installation method:

For overrunning cages

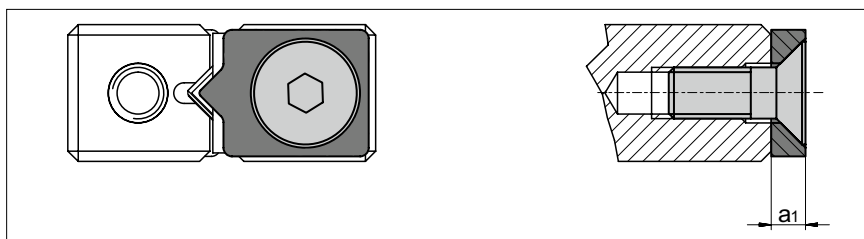

Size	GC 3	GC 6	GC 9	GC 12
a_1	2	3	4	5

Scope of supply:

Including fastening screws

End piece type GC-A (with wipers)

Compatible with:

Linear guideway R 3 to R 12

Design:

with felt wiper

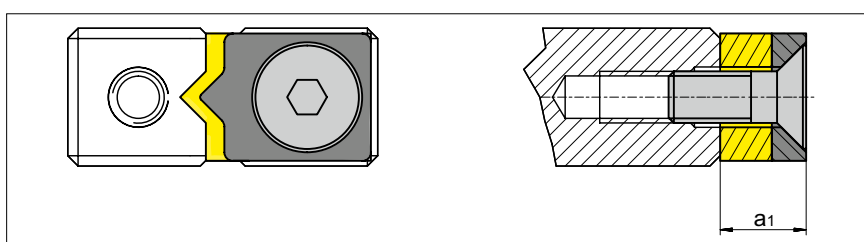

Size	GC-A 3	GC-A 6	GC-A 9	GC-A 12
a_1	5	6	7	8

Installation method:

No restrictions

Scope of supply:

Including fastening screws

Fastening screws with thin shaft type GD 3 to GD 12

Special feature:

To compensate for differences in hole pitches

Compatible with:

Linear guideway type R 3 to R 12

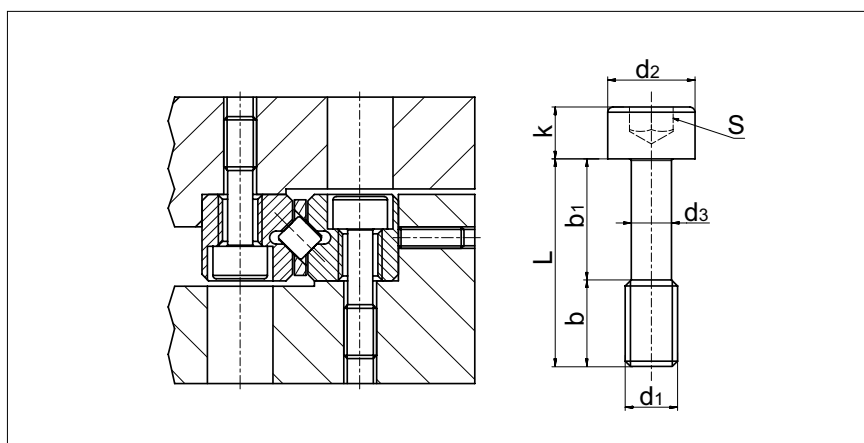

Type	Size	L	b	b_1	d_1	d_2	d_3	k	s	Max. tightening torque in Ncm	Compatible with linear guideways of size
GD	3	12	5	7	M3	5	2.3	3	2.5	102	R 3 & RD 3
	6	20	8	12	M5	8	3.9	5	4	460	R 6 & RD 6
	9	30	12	18	M6	8.5	4.6	6	5	792	R 9 & RD 9
	12	40	17	23	M8	11.3	6.25	8	6	1920	R 12 & RD 12

5 Linear guideways

5.2 Type RN



Type RN

The type RN linear guideway is the logical optimised version of the R guideway. It has identical installed dimensions, but due to the optimized contact surfaces of the guideway tracks is, however, higher performing. The reduced gap width between the guide rails also provides better protection against contaminants.

Benchmark data

Track and surface quality

- Finely ground supporting and/or locating surfaces and tracks (90° V-profile)

Materials (standard)

- Rails made of through hardened tool steel 1.2842, hardness 58 – 62 HRC
- For non-corrosive guideways tool steel 1.4034 and 1.4112 is used
- Rolling element made of through hardened roller bearing steel, hardness 58 – 64 HRC

Rolling element

- Roller

Speed

- 1 m/s

Acceleration

- 50 m/s²
- 300 m/s² with cage control

Accuracy

- RN linear guideways are available in three quality classes (see chapter 9)

Operating temperatures

- -40° C to +80° C

5 Linear guideways

Dimensions and load capacities of type RN

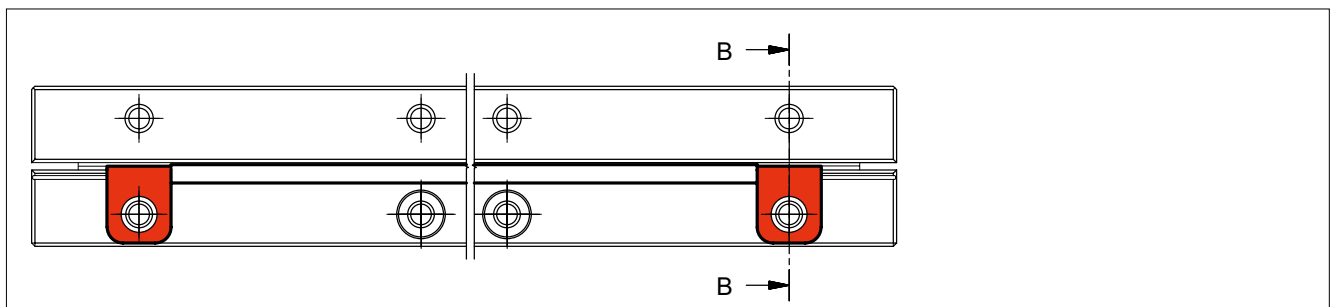
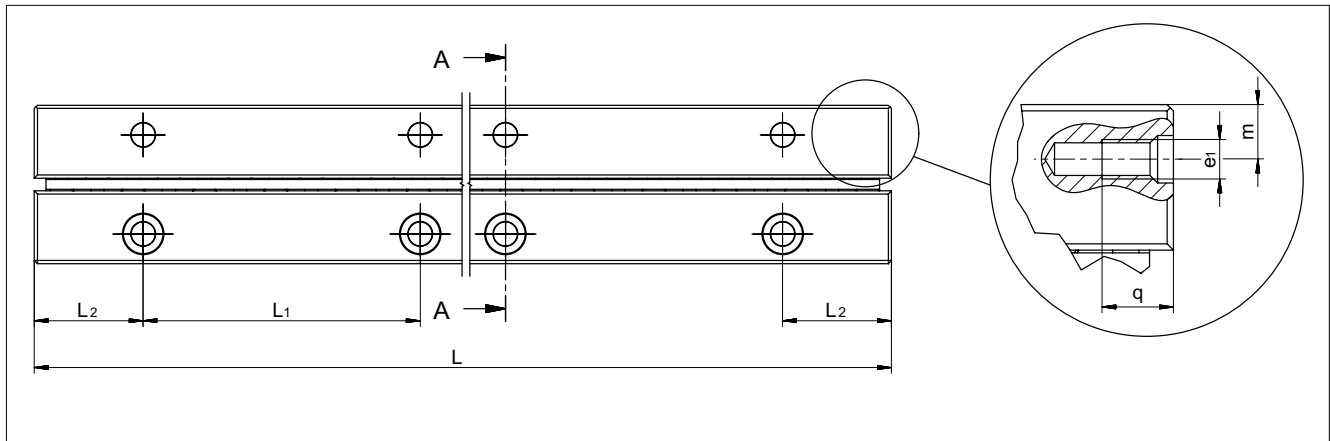

Type	Size	L in mm*	Weight in g	A	B	Dw	J	L ₁	L ₂	N	d	e	e ₁	f	g	m	q	s	Options (see chapter 7)	Accessories
				mm																
RN	3	50	24	18	8	3	8.7	25	12.5	3.5	6	M4	M3	3.3	4.8	4.8	7	0.85	SQ	Cage: - KBN 3 - KBS 3 End screw: - GAN 3 Fastening screw: - GD 3
		75	35																SSQ	
		100	47																RF	
		125	59																EG	
		150	71																ZG	
		175	82																HA	
		200	94																DU	
		225	106																DR	
		250	118																KS	
		275	129																	
300	141																			
RN	4	80	62	22	11	4.5	10.5	40	20	4.5	8	M5	M3	4.3	6.9	5.5	7	0.85	SQ	Cage: - KBN 4 - KBS 4 End screw: - GAN 4 Fastening screw: - GD 4
		120	93																SSQ	
		160	124																RF	
		200	155																EG	
		240	186																ZG	
		280	217																HA	
		320	248																DU	
		360	279																DR	
		400	310																KS	
RN	6	100	151	31	15	6.5	14.8	50	25	6	9.5	M6	M5	5.2	9.8	7.5	9	0.85	SQ	Cage: - KBN 6 - KBS 6 End screw: - GA 6 Fastening screw: - GD 6
		150	226																SSQ	
		200	301																RF	
		250	377																EG	
		300	452																ZG	
		350	527																HA	
		400	603																DU	
		450	678																DR	
500	753	KS																		

* The lengths shown are standard; other lengths can of course be delivered. The maximum lengths are listed on page 34.

5 Linear guideways

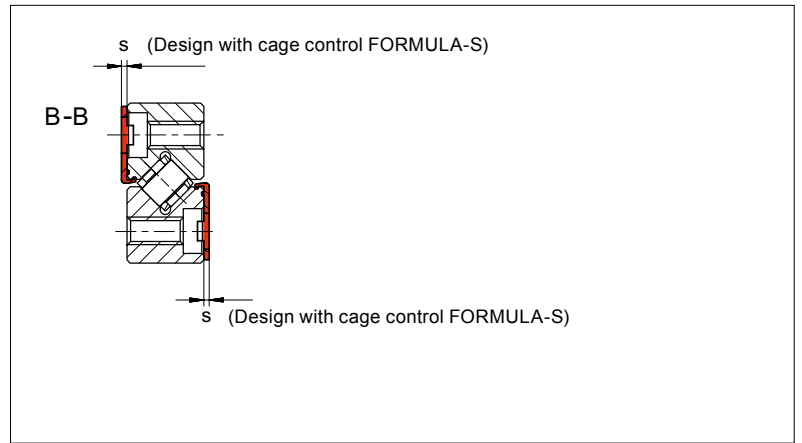
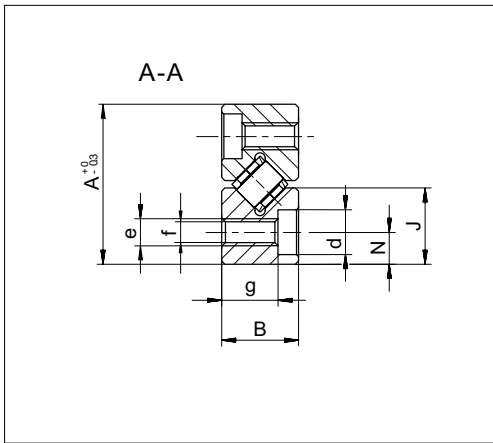

Type	Size	L in mm*	Weight in g	A	B	Dw	J	L ₁	L ₂	N	d	e	e ₁	f	g	m	q	s	Options (see chapter 7)	Accessories
				mm																
RN	9	200	659	44	22	9	21.1	100	50	9	10.5	M8	M6	6.8	15.8	11.5	9	-	SQ SSQ RF EG ZG HA DU	Cage: - KBN 9 End screw: - GA 9 Fastening screw: - GD 9
		300	988																	
		400	1'318																	
		500	1'647																	
		600	1'976																	
		700	2'306																	
		800	2'635																	
RN	12	200	1'086	58	28	12	27.6	100	50	12	13.5	M10	M8	8.5	19.8	15	12	-	SQ SSQ RF EG ZG HA DU	Cage: - KBN 12 End screw: - GA 12 Fastening screw: - GD 12
		300	1'628																	
		400	2'171																	
		500	2'714																	
		600	3'257																	
		700	3'800																	
		800	4'342																	
		900	4'885																	
1'000	5'428																			

* The lengths shown are standard; other lengths can of course be delivered. The maximum lengths are listed on page 34.

5 Linear guideways

Maximum lengths for type RN

Type / Size	Quality class	Max. lengths in standard material (in mm)	Max lengths in non-corrosive material (in mm)
RN 3	NQ	800	600
	SQ		
	SSQ	600	
RN 4	NQ	900	900
	SQ	600	600
	SSQ		
RN 6	NQ	1'500	1'400
	SQ		1'200
	SSQ	1'200	900
RN 9	NQ	3'000	3'000
	SQ		
	SSQ		
RN 12	NQ	3'000	3'000
	SQ		
	SSQ		

Rail chamfer

The detail of the rail chamfer is shown in the chart below. Please note that the part number and company logo are marked opposite to the datum and supporting surfaces.

Type / Size	Rail chamfer of reference edges in mm
RN 3	0.6 x 45°
RN 4	0.6 x 45°
RN 6	0.8 x 45°
RN 9	0.8 x 45°
RN 12	1.0 x 45°

5 Linear guideways

Accessories for type RN

Roller cage type KBN

Compatible with:

Linear guideway type RN

Sizes 3 to 12

Design:

Rollers fixed in place

Installation method:

For normal application and certain overrunning cage applications

Material:

POM (Vacuum-compatible up to 10^{-7} mbar)

Option:

Corrosion-resistant rollers

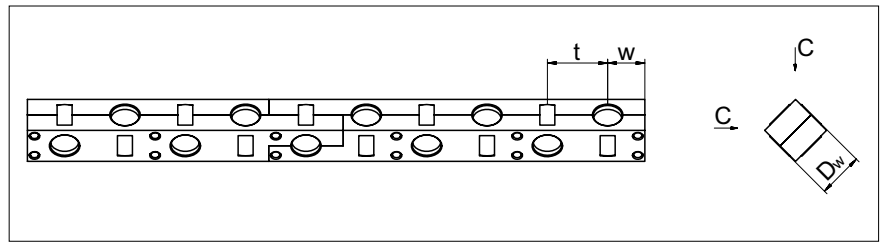

Type	Size	Dw	t	w	C per roller in N	Max. length in mm
KBN	3	3	5	approx. 3.5	410	900
	4	4.5	6.5	approx. 4	850	900
	6	6.5	8.5	approx. 5	1'800	1'500
	9	9	12	approx. 7.5	3'900	1'500
	12	12	15	approx. 9	6'500	1'500

Type KBS roller cage for the cage control FORMULA-S

Detailed information on

FORMULA-S is listed under chapter 7.8.

Compatible with:

Linear guideway type RN

Sizes 3 to 6

Design:

Rollers fixed in place

With integral pinion

Installation method:

For normal application and certain overrunning cage applications

Material:

POM (Vacuum-compatible up to 10^{-7} mbar)

Option:

Corrosion-resistant rollers

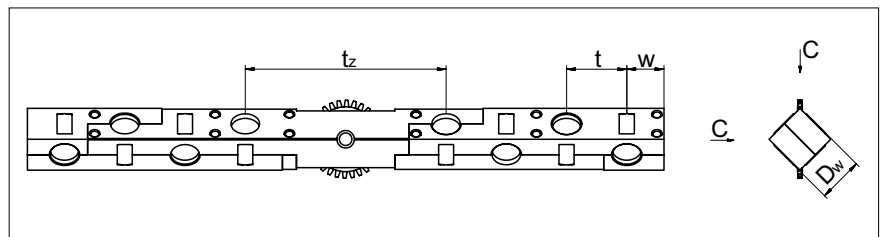

Type	Size	Dw	t	tz	w	C per roller in N	Max. length in mm
KBS	3	3	5	18	approx. 3.5	410	900
	4	4.5	6.5	23	approx. 4	850	900
	6	6.5	8.5	27	approx. 5	1'800	1'500

5 Linear guideways

Accessories for type RN

End screws type GAN

Compatible with:

Linear guideway RN 3 and RN 4

Installation method:

For horizontal installation

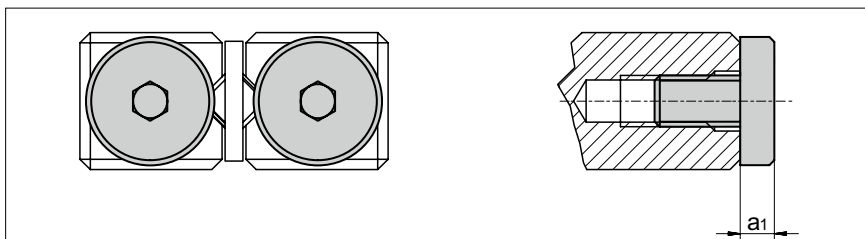

Size	GAN 3	GAN 4
a_1	2	2

End screws type GA

Compatible with:

Linear guideway RN 6 to RN 12

Installation method:

For horizontal installation

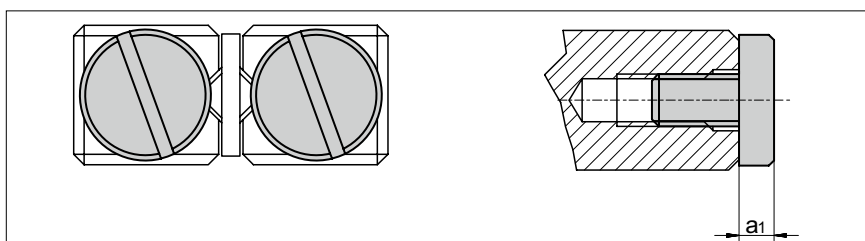

Size	GA 6	GA 9	GA 12
a_1	3	3	3

Fastening screws with thin shaft type GD 3 to GD 12

Special feature:

To compensate for differences in hole pitches

Compatible with:

Linear guideway type RN 3 to RN 12

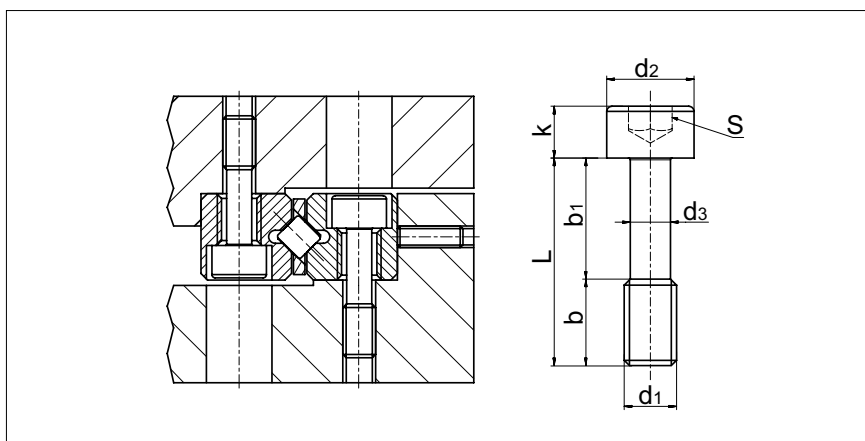

Type	Size	L	b	b ₁	d ₁	d ₂	d ₃	k	s	Max. tightening torque in Ncm	Compatible with linear guideways of size
GD	3	12	5	7	M3	5	2.3	3	2.5	102	RN 3
	4	16	7	9	M4	6.5	3	4	3	232	RN 4
	6	20	8	12	M5	8	3.9	5	4	460	RN 6
	9	30	12	18	M6	8.5	4.6	6	5	792	RN 9
	12	40	17	23	M8	11.3	6.25	8	6	1920	RN 12

5 Linear guideways

5.3 Type RNG



Type RNG

Like type RN, the type RNG linear guideway is based on the type R linear guideway. Like type RN, it has larger contact surfaces for the guideway tracks, which means its performance is significantly enhanced. Compared with types R and RN its cross-section is, however, smaller, which means that it represents a cost-effective solution without compromise.

Benchmark data

Track and surface quality

- Finely ground supporting and/or locating surfaces and tracks (90° V-profile)

Materials (standard)

- Rails from through hardened tool steel 1.2842, hardness 58 - 62 HRC.
- For non-corrosive guideways tool steel 1.4034 and 1.4112 is used.
- Rolling element made of through hardened roller bearing steel, hardness 58 - 64 HRC.

Rolling element

- Roller

Speed

- 1 m/s

Acceleration

- 50 m/s²
- 300 m/s² with cage control

Accuracy

- RNG linear guideways are available in three quality classes (see chapter 9)

Operating temperatures

- -40° C to +80° C

5 Linear guideways

Dimensions and load capacities of type RNG

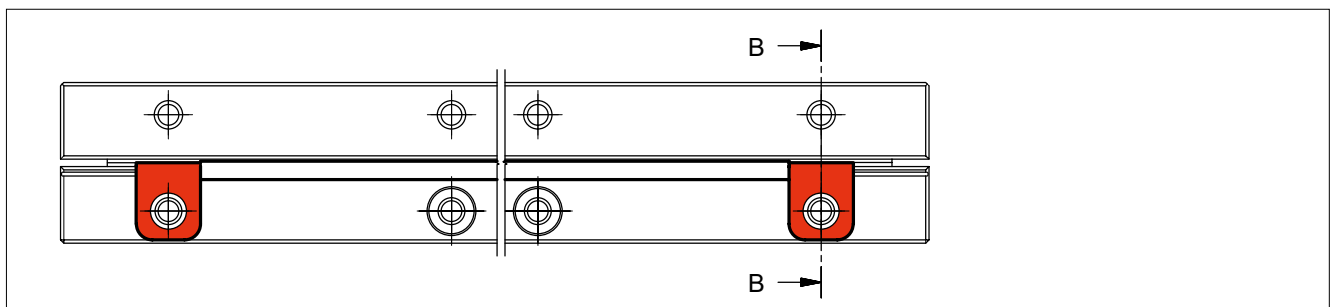
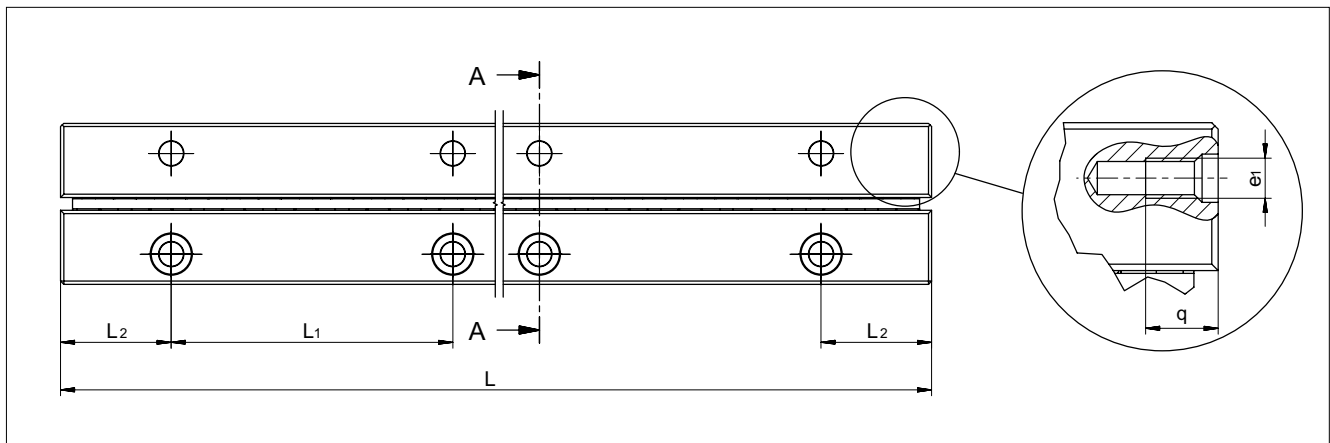

Type	Size	L in mm*	Weight in g	A	B	Dw	J	L ₁	L ₂	N	d	e	e ₁	f	g	m	q	u	s	Options (see chapter 7)	Accessories
				mm																	
RNG	4	50	27	19	9	4.5	9	25	12.5	3.5	5.5	M3	M3	2.65	6.3	3.5	6	-	0.85	SQ	Cage: - KBN 4 - KBS 4 End pieces: - GBN 4 - GCN 4 - GCN-A 4 Fastening screw: - GDN 4
		75	41																	RF	
		100	55																	EG	
		125	69																	ZG	
		150	83																	HA	
		175	97																	DU	
		200	111																	DR	
		225	125																	KS	
		250	139																		
		275	153																		
300	167																				
RNG	6	100	92	25	12	6.5	12	25	12.5	5	7	M4	M3	3.3	8.8	5	6	-	0.85	SQ	Cage: - KBN 6 - KBS 6 End pieces: - GBN 6 - GCN 6 - GCN-A 6 Fastening screw: - GDN 6
		150	138																	SSQ	
		200	184																	RF	
		250	230																	EG	
		300	276																	ZG	
		350	322																	HA	
		400	368																	DU	

* The lengths shown are standard; other lengths can of course be delivered. The maximum lengths are listed on page 40.

5 Linear guideways

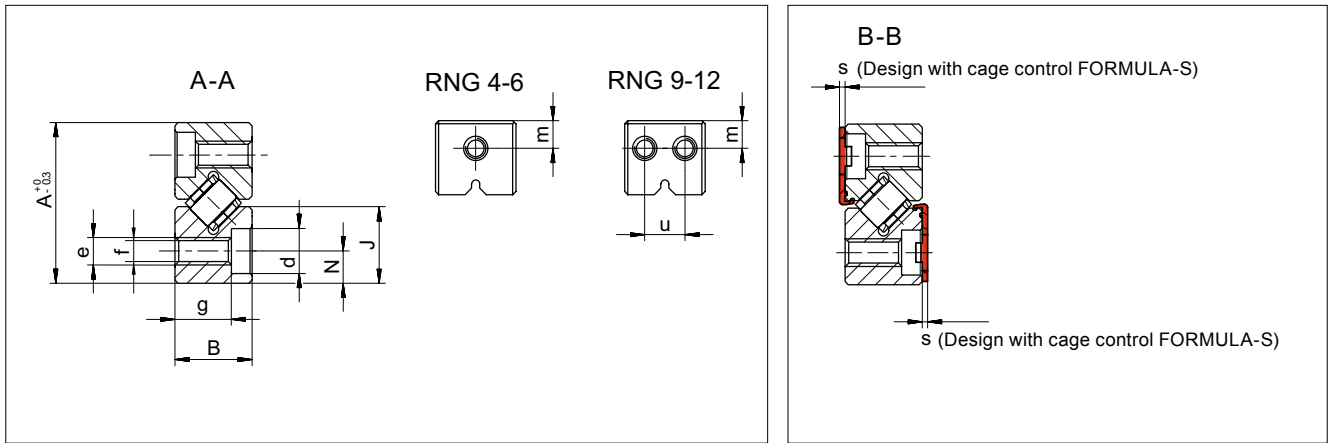

Type	Size	L in mm*	Weight in g	A	B	Dw	J	L ₁	L ₂	N	d	e	e ₁	f	g	m	q	u	s	Options (see chapter 7)	Accessories
				mm																	
RNG	9	100	150	33	16	9	16	25	12.5	6	8.5	M5	M3	4.4	11.8	8	6	8	0.85	SQ SSQ RF EG ZG HA DU DR KS	Cage: - KBN 9 - KBS 9 End pieces: - GBN 9 - GCN 9 - GCN-A 9 Fastening screw: - GDN 9
		150	230																		
		200	310																		
		250	390																		
		300	470																		
		350	550																		
		400	630																		
		450	710																		
500	790																				
RNG	12	200	600	45	22	12	22	50	25	8	12	M8	M5	6.8	15.8	11	7.5	10	-	SQ SSQ RF EG ZG HA DU	Cage: - KBN 12 End pieces: - GBN 12 - GCN 12 - GCN-A 12 Fastening screw: - GDN 12
		300	905																		
		400	1'207																		
		500	1'508																		
		600	1'810																		
		700	2'125																		
		800	2'430																		
		900	2'734																		
1'000	3'038																				

* The lengths shown are standard; other lengths can of course be delivered. The maximum lengths are listed on page 40.

5 Linear guideways

Maximum lengths for type RNG

Type / Size	Quality class	Max. lengths in standard material (in mm)	Max lengths in non-corrosive material (in mm)
RNG4	NQ	900	900
	SQ		
	SSQ	600	600
RNG6	NQ	1'500	1'400
	SQ		1'200
	SSQ	1'200	900
RNG9	NQ	3'000	3'000
	SQ		
	SSQ		
RNG12	NQ	3'000	3'000
	SQ		
	SSQ		

Rail chamfer

The detail of the rail chamfer is shown in the chart below. Please note that the part number and company logo are marked opposite to the datum and supporting surfaces.

Type / Size	Rail chamfer of reference edges in mm
RNG 4	0.4 x 45°
RNG 6	0.5 x 45°
RNG 9	0.8 x 45°
RN 12	0.8 x 45°

5 Linear guideways

Type RNG accessories

Roller cage type KBN

Compatible with:

Type RNG linear guideway
Sizes 4 to 12

Design:

Rollers fixed in place

Installation method:

For normal application and certain
overrunning cage applications

Material:

POM (Vacuum-compatible up to 10^{-7}
mbar)

Option:

Corrosion-resistant rollers

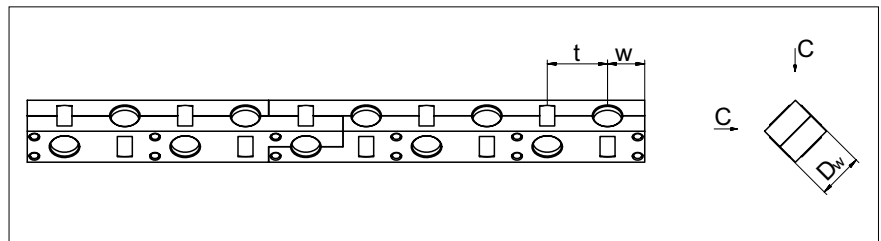

Type	Size	Dw	t	w	C per roller in N	Max. length in mm
KBN	4	4.5	6.5	approx. 4	850	900
	6	6.5	8.5	approx. 5	1'800	1'500
	9	9	12	approx. 7.5	3'900	1'500
	12	12	15	approx. 9	6'500	1'500

Type KBS roller cage for the cage control FORMULA-S

Detailed information on
FORMULA-S is listed under chapter
7.8.

Compatible with:

Type RNG linear guideway
Sizes 4 to 9

Design:

Rollers fixed in place
With integral pinion

Installation method:

For normal application and certain
overrunning cage applications

Material:

POM (Vacuum-compatible up to 10^{-7}
mbar)

Option:

Corrosion-resistant rollers

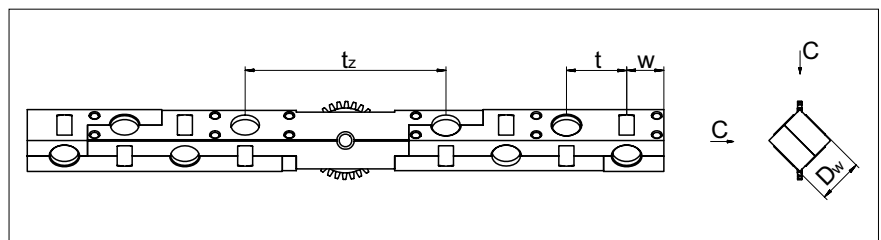

Type	Size	Dw	t	tz	w	C per roller in N	Max. length in mm
KBS	4	4.5	6.5	23	approx. 4	850	900
	6	6.5	8.5	27	approx. 5	1'800	1'500
	9	9	12	40	approx. 7.5	3'900	1'500

5 Linear guideways

Type RNG accessories

End piece type GBN 4 and GBN 6

Compatible with:

Linear guideway RNG 4 and RNG 6

Installation method:

No restrictions

Scope of supply:

Including fastening screws

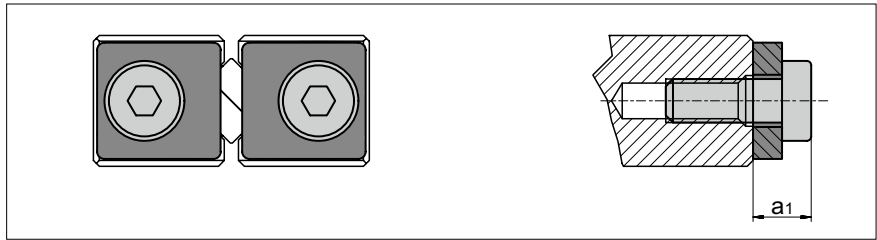

Size	GBN 4	GBN 6
a ₁	4	4

End piece type GBN 9 and GBN 12

Compatible with:

Linear guideway RNG 9 and RNG 12

Installation method:

No restrictions

Scope of supply:

Including fastening screws

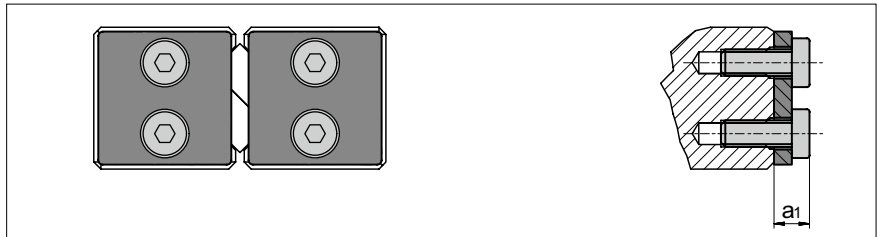

Size	GBN 9	GBN 12
a ₁	4	8.5

End piece type GCN 4 and GCN 6

Special feature:

For overrunning cage

Compatible with:

Linear guideway RNG 4 and RNG 6

Installation method:

No restrictions

Scope of supply:

Including fastening screws

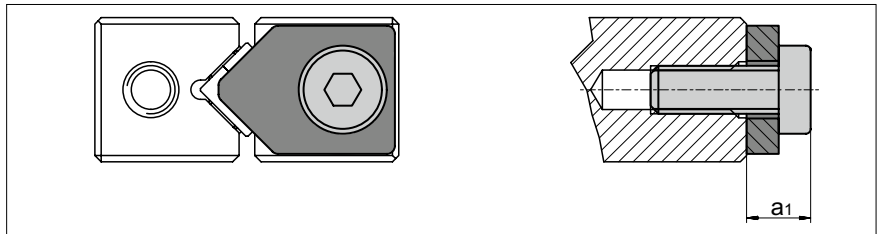

Size	GCN 4	GCN 6
a ₁	4	4

End piece type GCN 9 and GCN 12

Special feature:

For overrunning cage

Compatible with:

Linear guideway RNG 9 and RNG 12

Installation method:

No restrictions

Scope of supply:

Including fastening screws

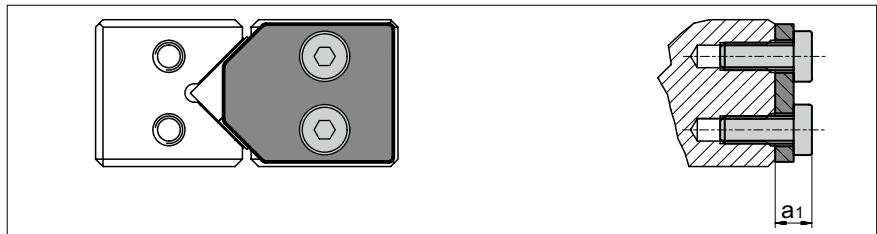

Size	GCN 9	GCN 12
a ₁	4	8.5

5 Linear guideways

Type RNG accessories

End piece type GCN-A 4 and GCN-A 6

Special feature:

With wipers made of plastic

Compatible with:

Linear guideway RNG 4 and RNG 6

Installation method:

No restrictions

Scope of supply:

Including fastening screws

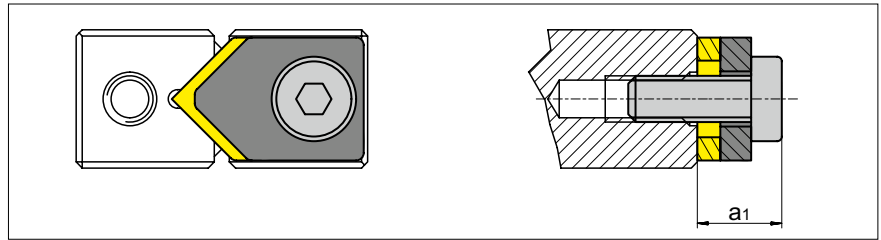

Size	GCN-A 4	GCN-A 6
a_1	5.5	5.5

End piece type GCN-A 9 and GCN-A 12

Special feature:

With wipers made of plastic

Compatible with:

Linear guideway RNG 9 and RNG 12

Installation method:

No restrictions

Scope of supply:

Including fastening screws

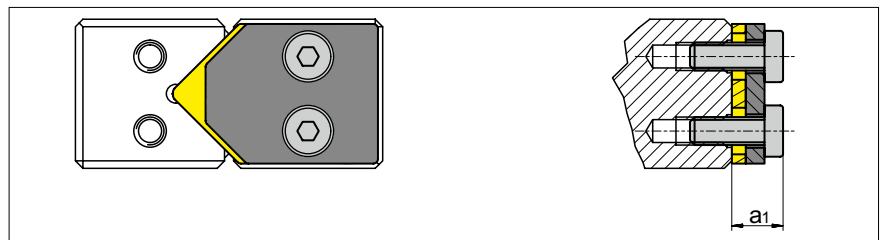

Size	GCN-A 9	GCN-A 12
a_1	5.5	10

Fastening screws with thin shaft type GDN 4 to GDN 12

Special feature:

To even out differences in the hole spacings

Compatible with:

Linear guideway type RNG 4 to RNG 12

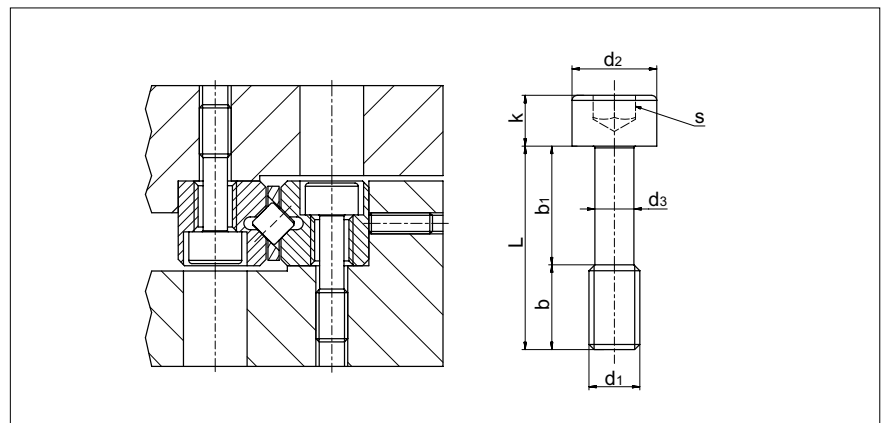

Type	Size	L	b	b_1	d_1	d_2	d_3	k	s	Max. tightening torque in Ncm	Compatible with linear guideways of size
GDN	4	12	5	7	M2.5	4.5	1.85	2.5	2	58	RNG 4
	6	16	5	11	M3	5.5	2.3	3	2.5	102	RNG 6
	9	25	11	14	M4	7	3	4	3	232	RNG 9
	12	30	12	18	M6	10	4.6	6	5	792	RNG 12

5 Linear guideways

5.4 Type N/O



Type N/O

The type N/O linear guideways are equipped with needle cages and are particularly suitable for applications involving high loads. SCHNEEBERGER N/O bearings have a lower moving resistance due to our composite cage.

Benchmark data

Track and surface quality

- Finely ground supporting and/or locating surfaces and tracks (90° V-profile)

Materials (standard)

- Rails from through hardened tool steel 1.2842, hardness 58 – 62 HRC.
- For non-corrosive guideways tool steel 1.4034 and 1.4112 is used.
- Rolling element made of through hardened roller bearing steel, hardness 58 – 64 HRC.

Rolling element

- Needle

Speed

- 1 m/s

Acceleration

- 50 m/s²
- 200 m/s² with cage control

Accuracy

- Type N/O linear guideways are available in three quality classes (see chapter 9)

Operating temperatures

- -40° C to +80° C

5 Linear guideways

Dimensions and load capacities of type N/O

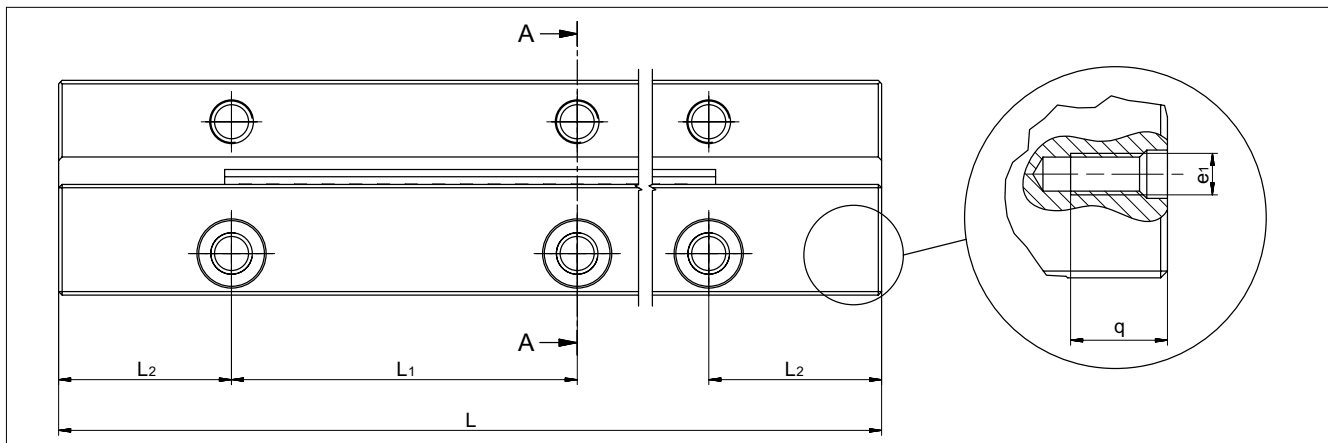

Type	Size	L in mm*	Weight in g		A	B	Dw	F	J	J ₁	L ₁	L ₂	N	d	e	e ₁	f	g	m	m ₁	q	u	u ₁	Options (see chapter 7)	Accessories
			Type N	Type O																					
N/O	62015	100	146	164	31	15	2	11	16	18	50	25	6	9.5	M6	M3	5.2	9.8	7.5	4.5	7	7	7	SQ SSQ RF EG ZG HA DU KZST	Cage: - HW 10 End pieces - GFN 62015 - GFO 62015 - GH 62015 - GH-A 62015 - GW 62015 - GW-A 62015 Fastening screw: - GD 6
		150	219	246																					
		200	292	328																					
		250	365	410																					
		300	438	492																					
		350	511	574																					
		400	584	656																					
		450	657	738																					
500	730	820																							
N/O	92025	200	685	695	44	22	2	15	24	24.5	100	50	9	10.5	M8	M4	6.8	15.8	11	6	11	10	10	SQ SSQ RF EG ZG HA DU KZST	Cage: - HW 15 - SHW 15 End pieces - GFN 92025 - GFO 92025 - GH 92025 - GH-A 92025 - GW 92025 - GW-A 92025 Fastening screw: - GD 9
		300	1'020	1030																					
		400	1'360	1373																					
		500	1'700	1717																					
		600	2'025	2035																					
		700	2'360	2370																					
		800	2'697	2709																					
		N/O	2025	200																					
300	1'386			1'350																					
400	1'848			1'800																					
500	2'310			2'250																					
600	2'772			2'700																					
700	3'234			3'150																					
800	3'696			3'600																					
900	4'158			4'050																					
1'000	4'620			4'500																					
1'100	5'082			4'950																					
1'200	5'544			5'400																					
1'400	6'468			6'300																					
1'600	7'392	7'200																							

* The lengths shown are standard; other lengths can of course be delivered. The maximum lengths are listed on page 48.

5 Linear guideways

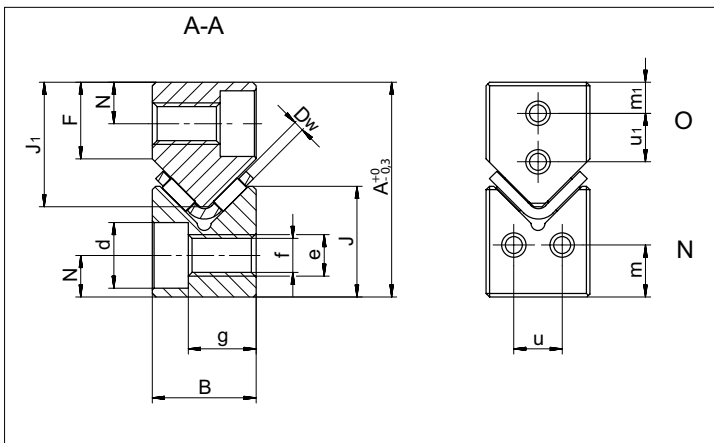

Type	Size	L in mm*	Weight in g		A	B	Dw	F	J	J ₁	L ₁	L ₂	N	d	e	e ₁	f	g	m	m ₁	q	u	u ₁	Options (see chapter 7)	Accessories
			Type N	Type O																					
N/O	2535	300	1'905	1'995	62	30	2.5	22	34	35	100	50	12	16.5	M12	M6	10.5	19.8	15	8	11	18	12	SQ SSQ RF EG ZG HA DU KZST	Cage: - HW 20 - SHW 20 End pieces - GFN 2535 - GFO 2535 - GH 2535 - GH-A 2535 - GW 2535 - GW-A 2535 Fastening screw: - GD 2535
		400	2'540	2'660																					
		500	3'175	3'325																					
		600	3'810	3'990																					
		700	4'445	4'655																					
		800	5'080	5'320																					
		900	5'715	5'985																					
		1'000	6'350	6'650																					
		1'100	6'985	7'315																					
		1'200	7'620	7'980																					
		1'400	8'890	9'310																					
1'600	10'160	10'640																							
N/O	3045	400	3'660	3'460	74	35	3	25	42.5	40	100	50	14	18.5	M14	M6	12.5	22.8	18	10	11	19	16	SQ SSQ RF EG ZG HA DU KZST	Cage: - HW 25 - SHW 25 End pieces - GFN 3045 - GFO 3045 - GH 3045 - GH-A 3045 - GW 3045 - GW-A 3045 Fastening screw: - GD 3045
		500	4'575	4'325																					
		600	5'490	5'190																					
		700	6'405	6'055																					
		800	7'320	6'920																					
		900	8'235	7'785																					
		1'000	9'150	8'650																					
		1'100	1'007	9'515																					
		1'200	10'980	10'380																					
		1'400	12'810	12'110																					
		1'600	14'640	13'840																					
N/O	3555	500	6'156	6'088	78	45	3.5	25	45	45	100	50	14	18.5	M14	M6	12.5	32.5	18	12	11	29	20	SQ SSQ RF EG ZG HA DU KZST	Cage: - HW 30 - SHW 30 End pieces - GFN 3555 - GFO 3555 - GH 3555 - GH-A 3555 - GW 3555 - GW-A 3555 Fastening screw: - GD 3555
		600	7'387	7'306																					
		700	8'618	8'523																					
		800	9'850	9'741																					
		900	11'081	10'958																					
		1'000	12'312	12'176																					
		1'100	13'543	13'394																					
		1'200	14'774	14'611																					
		1'400	17'237	17'046																					
		1'600	19'699	19'482																					

* The lengths shown are standard; other lengths can of course be delivered. The maximum lengths are listed on page 48.

5 Linear guideways

Maximum lengths type N/O

Type /Size	Quality class (see chapter 9)	Max. lengths in standard material (in mm)	Max lengths in non-corrosive material (in mm)
N/O 62015	NQ	1'500	900
	SQ	1'200	
	SSQ		
N/O 92025	NQ	3'000	3'000
	SQ		
	SSQ		
N/O 2025	NQ	3'000	3'000
	SQ		
	SSQ		
N/O 2535	NQ	3'000	3'000
	SQ		
	SSQ		
N/O 3045	NQ	3'000	3'000
	SQ		
	SSQ		
N/O 3555	NQ	3'000	3'000
	SQ		
	SSQ		

Rail chamfer

The detail of the rail chamfer is shown in the chart below. Please note that the part number and company logo are marked opposite to the datum and supporting surfaces.

Type / Size	Rail chamfer of reference edges in mm
N/O 62015	0.5 x 45°
N/O 92025	0.5 x 45°
N/O 2025	0.5 x 45°
N/O 2535	0.5 x 45°
N/O 3045	1.0 x 45°
N/O 3555	1.0 x 45°

5 Linear guideways

Accessories for type N/O

Needle cage type SHW

Design:

Needles fixed in plastic provides lower displacement forces and smoother running

Installation method:

For normal application and certain overrunning cage applications

Material:

Stainless steel and plastic PA 12 GF 30 %

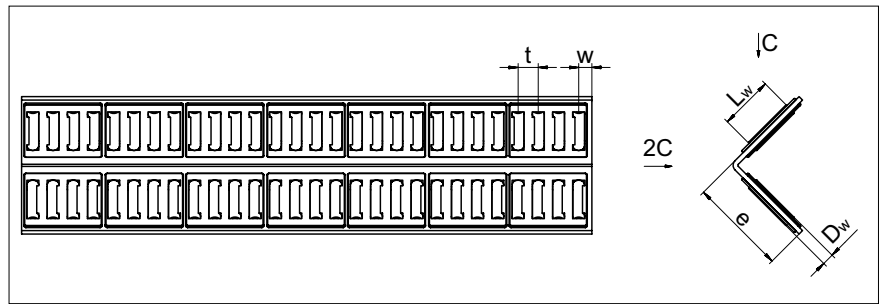

Type	Size	Dw	Lw	e	t	w	C per needle in N	Compatible with linear guideways type	max. length in mm
SHW	15	2	6.8	14	4	approx. 2.9	750	N/O 92025 and 2025	1'500
	20	2.5	9.8	19	4.75	approx. 3.4	1'375	N/O 2535	1'500
	25	3	13.8	25	5.2	approx. 3.6	2'350	N/O 3045	1'500
	30	3.5	17.8	30	6.1	approx. 4.3	3'600	N/O 3555	1'500

Needle cage type SHW with cage control (KZST)

Detailed information on the cage control is listed under Chapter 7.9.

Design:

Needles fixed in plastic. Thus smaller displacement forces and smoother running.

Installation method:

For normal application and certain overrunning cage applications

Material:

Stainless steel and plastic PA 12 GF 30 %

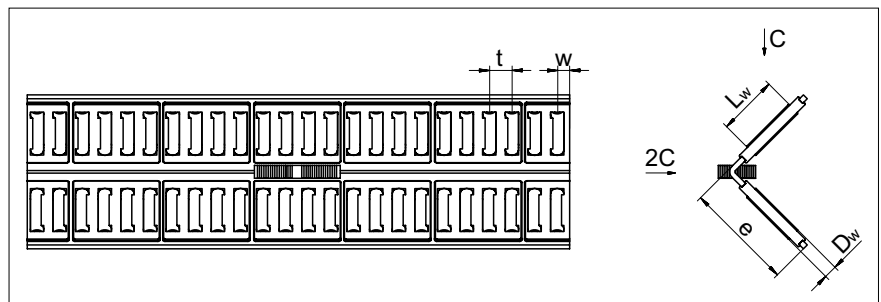

Type	Size	Dw	Lw	e	t	w	C per needle in N	Compatible with linear guideways type	max. length in mm
SHW	15	2	6.8	14	4	approx. 2.9	750	N/O 92025 and 2025	1'500
	20	2.5	9.8	19	4.75	approx. 3.4	1'375	N/O 2535	1'500
	25	3	13.8	25	5.2	approx. 3.6	2'350	N/O 3045	1'500
	30	3.5	17.8	30	6.1	approx. 4.3	3'600	N/O 3555	1'500

5 Linear guideways

Accessories for type N/O

Needle cage type HW

Design:

Needles fixed

Installation method:

For normal application and certain overrunning cage applications

Material:

Standard

- Size HW 10 is made out of tool steel

- All other sizes in aluminium

Optional

- All cages are available in steel

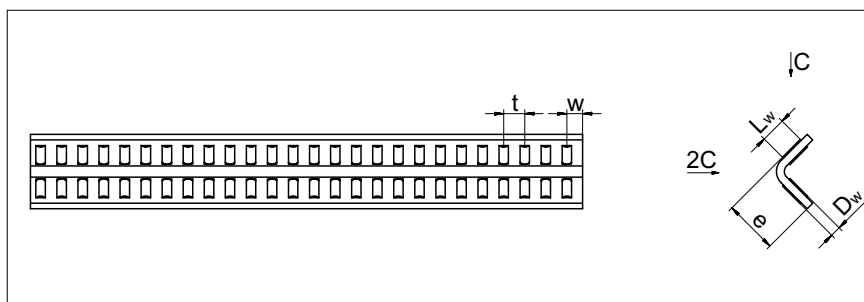

Type	Size	Dw	L _w	e	t	w	C per needle in N	Compatible with linear guideways type	max. length in mm
HW	10	2	4.8	10	4	approx. 3	530	N/O 62015	1'980
	15	2	6.8	14	4.5	approx. 3.5	750	N/O 92025	1'950
	16	2	8.8	16	3.8	approx. 2.8	970	N/O 2025	1990
	20	2.5	9.8	20	5.5	approx. 4	1'375	N/O 2535	1'970
	25	3	13.8	25	6	approx. 4.5	2'350	N/O 3045	1'940
	30	3.5	17.8	30	7	approx. 5	3'600	N/O 3555	1'980

Needle cage type HW with cage control (KZST)

Detailed information on the cage control is listed under Chapter 7.9.

Design:

Needles fixed

Installation method:

For normal application and certain overrunning cage applications

Material:

Standard

- Size HW 10 is made out of tool steel

- All other sizes in aluminium

Optional

- All cages are available in steel

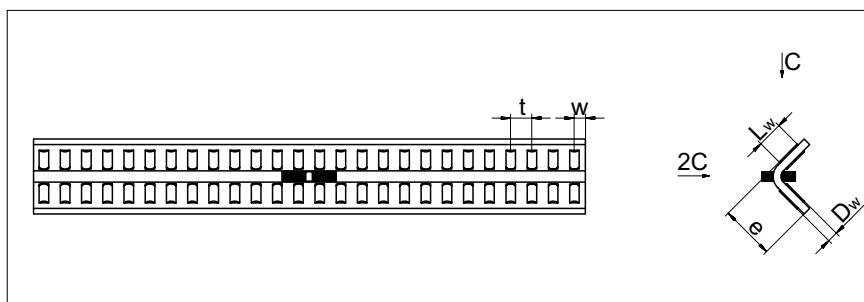

Type	Size	Dw	L _w	e	t	w	C per needle in N	Compatible with linear guideways type	max. length in mm
HW	10	2	4.8	10	4	approx. 3	530	N/O 62015	1'980
	15	2	6.8	14	4.5	approx. 3.5	750	N/O 92025	1'950
	16	2	8.8	16	3.8	approx. 2.8	970	N/O 2025	1990
	20	2.5	9.8	20	5.5	approx. 4	1'375	N/O 2535	1'970
	25	3	13.8	25	6	approx. 4.5	2'350	N/O 3045	1'940
	30	3.5	17.8	30	7	approx. 5	3'600	N/O 3555	1'980

5 Linear guideways

Accessories for type N/O

End piece type GH

Special feature:
For overrunning cage

Installation method:
No restrictions

Scope of supply:
Including fastening screws

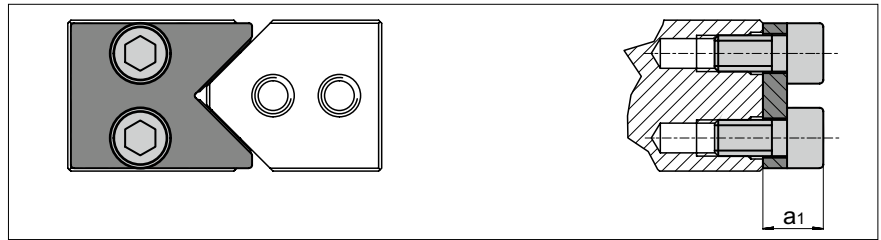

Size	62'015	92'025	2'025	2'535	3'045	3'555
a ₁	6	7	10	10	10	11

End piece type GH-A

Special feature:
Wipers made of felt

Installation method:
No restrictions

Scope of supply:
Including fastening screws

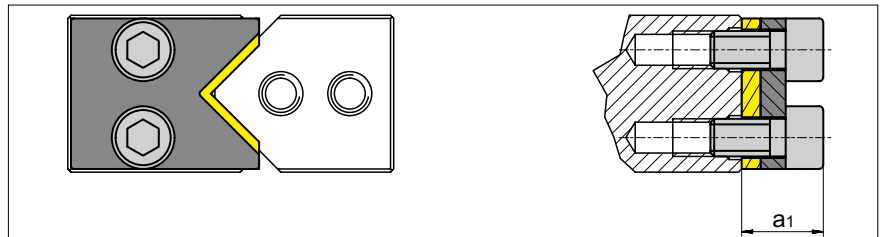

Size	62'015	92'025	2'025	2'535	3'045	3'555
a ₁	9	10	13	13	13	14

End piece type GFN/GFO

Installation method:
No restrictions

Scope of supply:
Including fastening screws

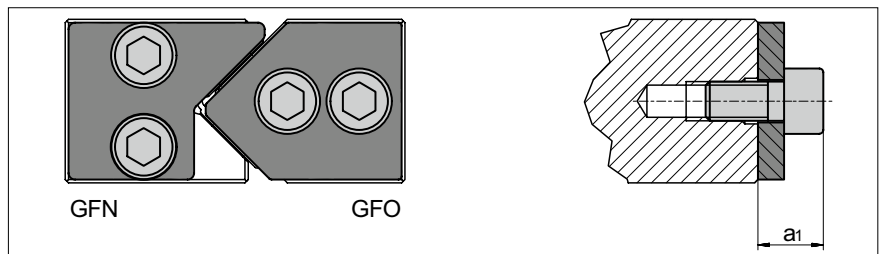

Size	62015	92025	2025	2535	3045	3555
a ₁	6	7	10	10	10	11

End piece type GW

Special feature:
For overrunning cage

Installation method:
No restrictions

Scope of supply:
Including fastening screws

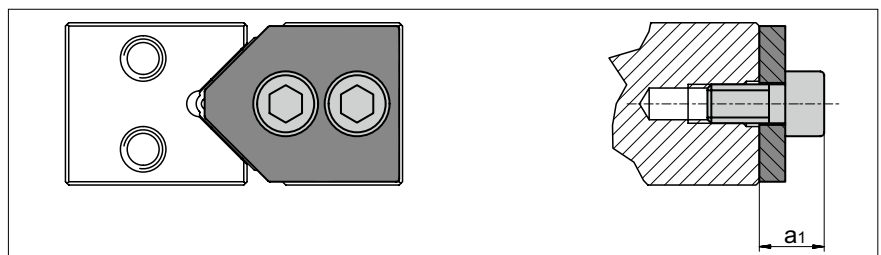

Size	62015	92025	2025	2535	3045	3555
a ₁	6	7	10	10	10	11

5 Linear guideways

Accessories for type N/O

End piece type GW-A

Special feature:

Felt Wipers

Installation method:

No restrictions

Scope of supply:

Including fastening screws

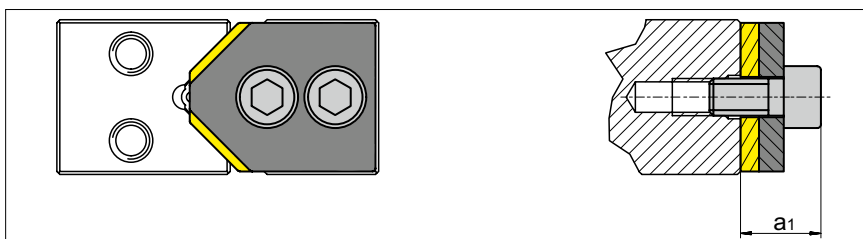

Size	62015	92025	2025	2535	3045	3555
a ₁	9	10	13	13	13	14

Fastening screws with thin shaft type GD

Special feature:

To compensate for differences in hole pitches

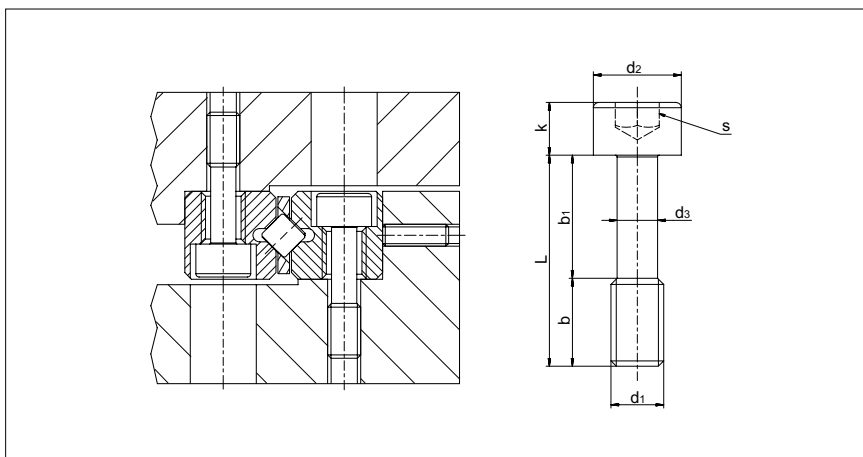

Type	Size	L	b	b ₁	d ₁	d ₂	d ₃	k	s	Max. tightening torque in Ncm	Compatible with linear guideways type
GD	6	20	8	12	M5	8	3.9	5	4	460	N/O 62015
	9	30	12	18	M6	8.5	4.6	6	5	792	N/O 92025
	2025	35	16	19	M8	11.3	6.25	8	6	1920	N/O 2025
	2535	40	18	22	M10	13.9	7.9	10	8	3840	N/O 2535
	3045	50	25	25	M12	15.8	9.6	12	10	6640	N/O 3045
	3555	60	25	35	M12	15.8	9.6	12	12	6640	N/O 3555

5 Linear guideways

5.5 Type M/V



Type M/V

the type M/V linear guideway is similar to type N/O, but differs in its external dimensions. Equipped with needle cages, it is particularly suitable for applications involving a higher load. SCHNEEBERGER M/V bearings have a lower moving resistance due to our composite cage.

Benchmark data

Track and surface quality

- Finely ground supporting and/or locating surfaces and tracks (90° V-profile)

Materials (standard)

- Rails from through hardened tool steel 1.2842, hardness 58 – 62 HRC.
- For non-corrosive guideways tool steel 1.4034 and 1.4112 is used.
- Rolling element made of through hardened roller bearing steel, hardness 58 – 64 HRC.

Rolling element

- Needle

Speed

- 1 m/s

Acceleration

- 50 m/s²
- 200 m/s² with cage control

Accuracy

- Type M/V linear guideways are available in three quality classes (see chapter 9)

Operating temperatures

- -40° C to +80° C

5 Linear guideways

Dimensions and load capacities type M/V

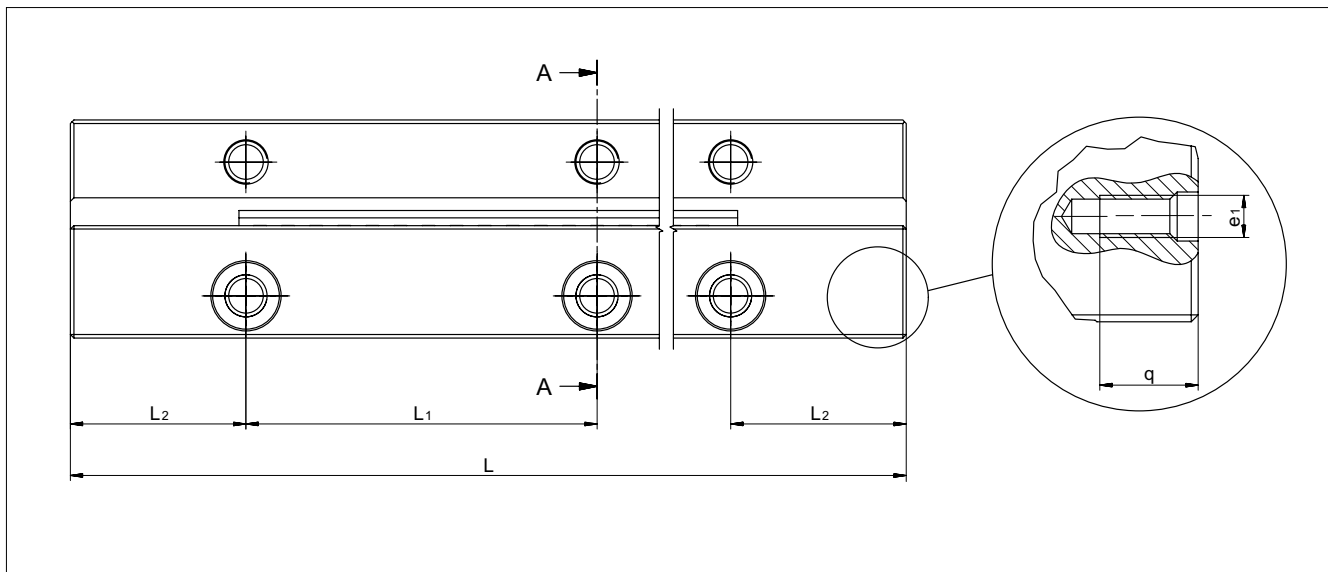

Type	Size	L in mm*	Weight in g		A	B	Dw	F	J	J ₁	L ₁	L ₂	N	a	d	e	e ₁	f	g	m	m ₁	q	t	u	u ₁	Options (see chapter 7)	Accessories
			Type M	Type V																							
M/V	3015	100	136	154	30	15	2	10.5	15.5	17.4	140 ¹⁾	40 ³⁾	5.5	0.7	8.5	M4	M3	5.3	10.5	8	5.5	7	15	7	7	SQ SSQ RF EG ZG HA KZST	Cage: - HW 10 End pieces - EM 3015 - EV 3015 - EAM 3015 - EAV 3015
		150	204	231																							
		200	272	308																							
		300	420	473																							
		400	560	631																							
		500	700	788																							
600	840	946																									
M/V	4020	100	261	274	40	20	2	13.5	22.5	22	280 ⁴⁾	80 ⁴⁾	7.5	1.3	11.5	M6	M5	7.5	13.2	10	5.5	8	20	11	10.5	SQ SSQ RF EG ZG HA KZST	Cage: - HW 15 - SHW 15 End pieces - EM 4020 - EV 4020 - EAM 4020 - EAV 4020
		150	392	411																							
		200	522	548																							
		300	820	815																							
		400	1'093	1'087																							
		500	1'367	1'358																							
600	1'640	1'630																									
M/V	5025	100	446	437	50	25	2	17	28	28	280 ⁴⁾	10	1.3	11.5	M6	M6	7.5	18.2	12	7	9	15	13	13	SQ SSQ RF EG ZG HA KZST	Cage: - HW 15 - HW 16 - SHW 15 End pieces - EM 5025 - EV 5025 - EAM 5025 - EAV 5025	
		200	893	874																							
		300	1'339	1'311																							
		400	1'786	1'748																							
		500	2'232	2'185																							
		600	2'678	2'622																							
		700	3'125	3'059																							
		800	3'571	3'496																							
		900	4'018	3'933																							
		1'000	4'464	4'370																							

¹⁾ for the 100 mm length, the following applies: L₁ = 35 mm (2 x)

²⁾ for the length 100 mm, the following applies: L₁ = 50 mm

³⁾ min. 15 mm

⁴⁾ min. 20 mm

* The lengths shown are standard; other lengths can of course be delivered. The maximum lengths are listed on page 56.

5 Linear guideways

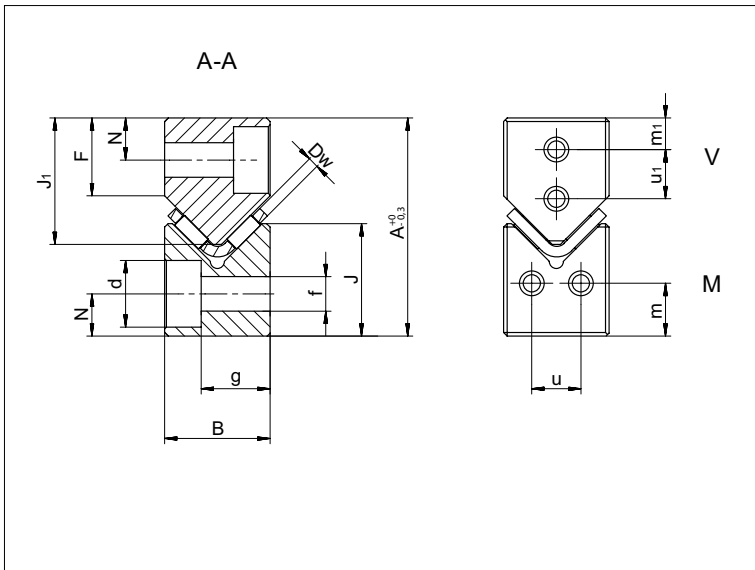

Type	Size	L in mm*	Weight in g		A	B	Dw	F	J	J ₁	L ₁	L ₂	N	a	d	e	e ₁	f	g	m	m ₁	q	t	u	u ₁	Options (see chapter 7)	Accessories
			Type M	Type V																							
M/V	6035	200	1'450	1'510	60	35	2.5	20	35	35.5	100	50	11	1.3	15	M8	M6	10	26	14	8	9	20	20	18	SQ SSQ RF EG ZG HA KZST	Cage: - HW 20 - SHW20 End pieces - EM 6035 - EV 6035 - EAM 6035 - EAV 6035
		300	2'176	2'265																							
		400	2'901	3'020																							
		500	3'626	3'775																							
		600	4'351	4'530																							
		700	5'076	5'285																							
		800	5'802	6'040																							
		900	6'527	6'795																							
1'000	7'252	7'550																									
M/V	7040	200	1'934	2'008	70	40	3	24	40	41.5	100	50	13	1.3	18.5	M10	M6	12.5	29	16	10	9	25	20	20	SQ SSQ RF EG ZG HA KZST	Cage: - HW 25 - SHW 25 End pieces - EM 7040 - EV 7040 - EAM 7040 - EAV 7040
		300	2'807	3'019																							
		400	3'743	4'025																							
		500	4'678	5'032																							
		600	5'821	6'038																							
		700	6'791	7'044																							
		800	7'499	8'051																							
		900	8'436	9'057																							
1'000	9'374	10'321																									
M/V	8050	300	4'014	4'271	80	50	3.5	26	45	48	100	50	14	1.3	20	M12	M6	14	37	20	10	9	30	30	25	SQ SSQ RF EG ZG HA KZST	Cage: - HW 30 - SHW 30 End pieces - EM 8050 - EV 8050 - EAM 8050 - EAV 8050
		400	5'352	5'694																							
		500	6'690	7'118																							
		600	8'290	8'544																							
		700	9'672	9'968																							
		800	10'700	11'530																							
		900	12'038	12'822																							
		1'000	13'375	14'247																							

* The lengths shown are standard; other lengths can of course be delivered. The maximum lengths are listed on page 56.

5 Linear guideways

Maximum lengths type M/V

Type / Size	Quality class	Max. lengths in standard material (in mm)	Max lengths in non-corrosive material (in mm)
M/V 3015	NQ	1'500	900
	SQ	1'200	
	SSQ		
M/V 4020	NQ	3'000	3'000
	SQ		
	SSQ		
M/V 5025	NQ	3'000	3'000
	SQ		
	SSQ		
M/V 6035	NQ	3'000	3'000
	SQ		
	SSQ		
M/V 7040	NQ	3'000	3'000
	SQ		
	SSQ		
M/V 8050	NQ	3'000	3'000
	SQ		

Rail chamfer

The detail of the rail chamfer is shown in the chart below. Please note that the part number and company logo are marked opposite to the datum and supporting surfaces.

Type / Size	Rail chamfer of reference edges in mm
M/V 3015	0.5 x 45°
M/V 4020	0.5 x 45°
M/V 5025	0.5 x 45°
M/V 6035	0.5 x 45°
M/V 7040	1.0 x 45°
M/V 8050	1.0 x 45°

5 Linear guideways

Accessories type M/V

Needle cage type SHW

Compatible with:

Linear guideway type M/V

Design:

Needles fixed in plastic provides lower displacement forces and smoother running

Installation method:

For normal application and certain overrunning cage applications

Material:

Stainless steel and plastic PA 12 GF 30 %

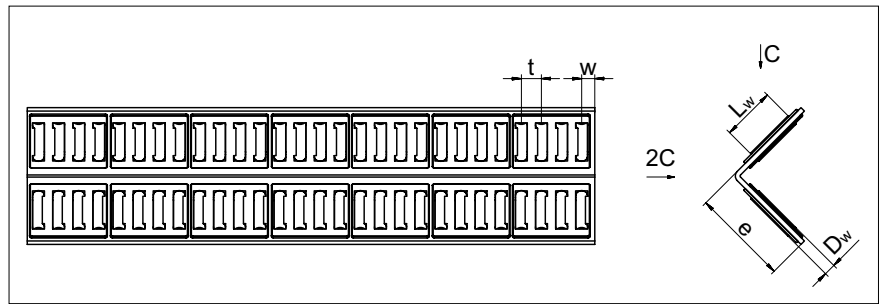

Type	Size	Dw	Lw	e	t	w	C per needle in N	Compatible with linear guideways type	max. length in mm
SHW	15	2	6.8	14	4	approx. 2.9	750	M/V 4020 and M/V 5025	1'500
	20	2.5	9.8	19	4.75	approx. 3.4	1'375	M/V 6035	1'500
	25	3	13.8	25	5.2	approx. 3.6	2'350	M/V 7040	1'500
	30	3.5	17.8	30	6.1	approx. 4.3	3'600	M/V 8050	1'500

Needle cage type SHW with cage control (KZST)

Detailed information on the cage control is listed under Chapter 7.9.

Compatible with:

Linear guideway type M/V

Design:

Needles fixed in plastic. Thus smaller displacement forces and smoother running.

Installation method:

For normal application and certain overrunning cage applications

Material:

Stainless steel and plastic PA 12 GF 30 %

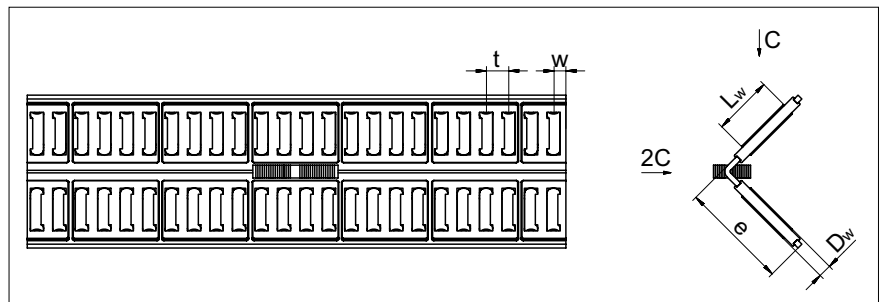

Type	Size	Dw	Lw	e	t	w	C per needle in N	Compatible with linear guideways type	max. length in mm
SHW	15	2	6.8	14	4	approx. 2.9	750	M/V 4020 and M/V 5025	1'500
	20	2.5	9.8	19	4.75	approx. 3.4	1'375	M/V 6035	1'500
	25	3	13.8	25	5.2	approx. 3.6	2'350	M/V 7040	1'500
	30	3.5	17.8	30	6.1	approx. 4.3	3'600	M/V 8050	1'500

5 Linear guideways

Accessories type M/V

Needle cage type HW

Compatible with:

Linear guideway type M/V

Design:

Needles fixed

Installation method:

Specifically suitable as an overrunning cage

Material:

Standard

- Size HW 10 is made out of tool steel
- All other sizes in aluminium

Optional

- All cages are available in steel

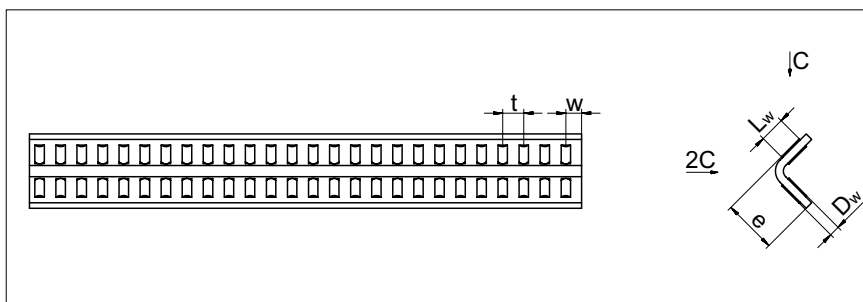

Type	Size	Dw	L _w	e	t	w	C per needle in N	Compatible with linear guideways type	max. length in mm
HW	10	2	4.8	10	4	approx. 3	530	M/V 3015	1'980
	15	2	6.8	14	4.5	approx. 3.5	750	M/V 4020 and M/V 5025	1'950
	16	2	8.8	16	3.8	approx. 2.8	970	M/V 5025	1'990
	20	2.5	9.8	20	5.5	approx. 4	1'375	M/V 6035	1'970
	25	3	13.8	25	6	approx. 4.5	2'350	M/V 7040	1'940
	30	3.5	17.8	30	7	approx. 5	3'600	M/V 8050	1'980

Needle cage type HW with cage control (KZST)

Detailed information on the cage control is listed under Chapter 7.9.

Compatible with:

Linear guideway type M/V

Design:

Needles fixed

Installation method:

Specifically suitable as an overrunning cage

Material:

Standard

- Size HW 10 is made out of tool steel
- All other sizes in aluminium

Optional

- All cages are available in steel

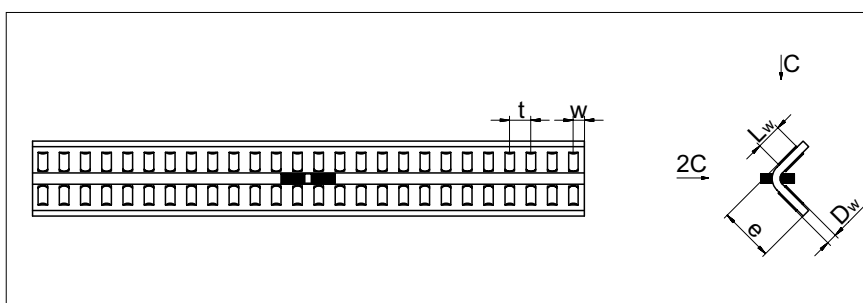

Type	Size	Dw	L _w	e	t	w	C per needle in N	Compatible with linear guideways type	max. length in mm
HW	10	2	4.8	10	4	approx. 3	530	M/V 3015	1'980
	15	2	6.8	14	4.5	approx. 3.5	750	M/V 4020 and M/V 5025	1'950
	16	2	8.8	16	3.8	approx. 2.8	970	M/V 5025	1'990
	20	2.5	9.8	20	5.5	approx. 4	1'375	M/V 6035	1'970
	25	3	13.8	25	6	approx. 4.5	2'350	M/V 7040	1'940
	30	3.5	17.8	30	7	approx. 5	3'600	M/V 8050	1'980

5 Linear guideways

Accessories type M/V

End piece type EM/EV

Compatible with:

For all M/V rail sizes

Installation method:

No restrictions

Scope of supply:

Including fastening screws

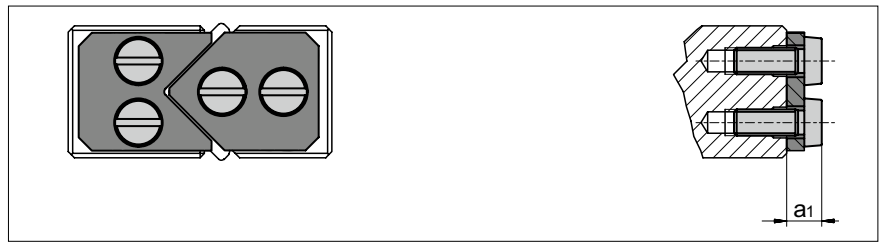

Size	3'015	4'020	5'025	6'035	7'040	8'050
a_1	5	8	9	9	9	9

End piece type EAM

Special feature:

With wipers made of plastic

Compatible with:

For all M/V rail sizes

Installation method:

No restrictions

Scope of supply:

Including fastening screws

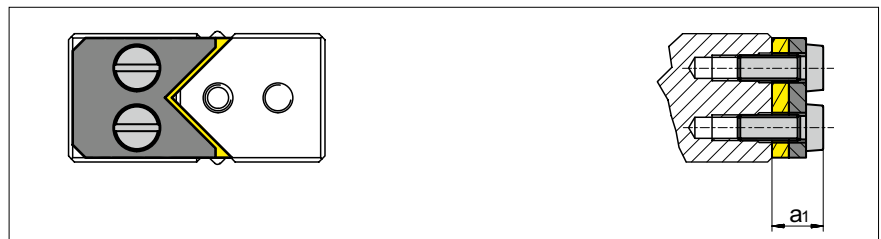

Size	3015	4020	5025	6035	7040	8050
a_1	7	10	11	11	11	11

End piece type EAV

Special feature:

With wipers made of plastic

Compatible with:

For all M/V rail sizes

Installation method:

No restrictions

Scope of supply:

Including fastening screws

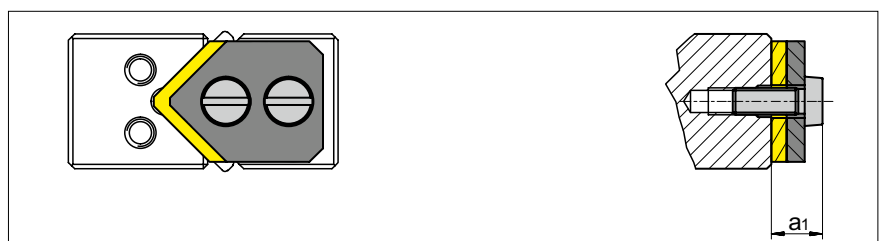

Size	3015	4020	5025	6035	7040	8050
a_1	7	10	11	11	11	11

6 Recirculating unit

6.1 Product specifications

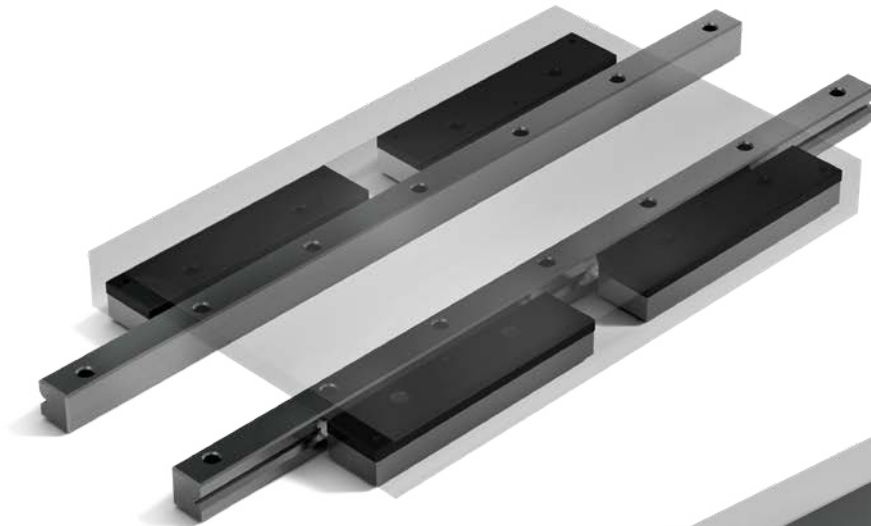

Application with recirculating units and linear guideways of type R



Application with recirculating units and a linear guideway of type RD

Recirculating units support high-precision, rigid and compact structures with unlimited travel. They are used as standard with linear guideways of type R or RD.

The SCHNEEBERGER product range includes recirculating units in different versions and for different load capacities; with rollers or balls, with damping elements or for dry runs.

The range is modular in structure and depending on the type includes sizes from 1 to 12.

6 Recirculating unit

6.1 Type SK and SKD



Type SK



Type SKD

The type SK recirculating unit is equipped with balls and is suitable for small to medium loads.

This recirculating unit is used combined with SCHNEEBERGER linear guideways of type R and/or RD. The SK units can be used in space saving designs that have equal loading in all directions.

Sizes 6 and 9 (size 12 on request) can additionally be equipped with damping elements (type designation SKD). These provide improved smoothness with slightly reduced load carrying capacity.

Benchmark data

Supporting structure

- Hardened and ground with high precision

Materials

- Supporting structure made of through hardened tool steel, hardness 58 - 62 HRC
- Rolling element made of through hardened roller bearing steel, hardness 58 - 64 HRC
- Transmission part in sizes 1, 2, 9 and 12 made of anodized aluminium
- Transmission part in sizes 3 and 6t depending on the length made of plastic or aluminium
- Non-corrosive version on request
- Damping elements for SKD made of plastic
- Wipers made of plastic

Wipers

- From size 3 interchangeable track wipers are made from plastic as standard fitted

Speed

- 2 m/s

Acceleration

- 50 m/s²

Operating temperatures

- -40° C to +80° C

Same installation with the following recirculating units

- SKC and SR

Can be combined with the following products

- Linear guideway type R and RD

6 Recirculating unit

Dimensions and load capacities type SK and SKD

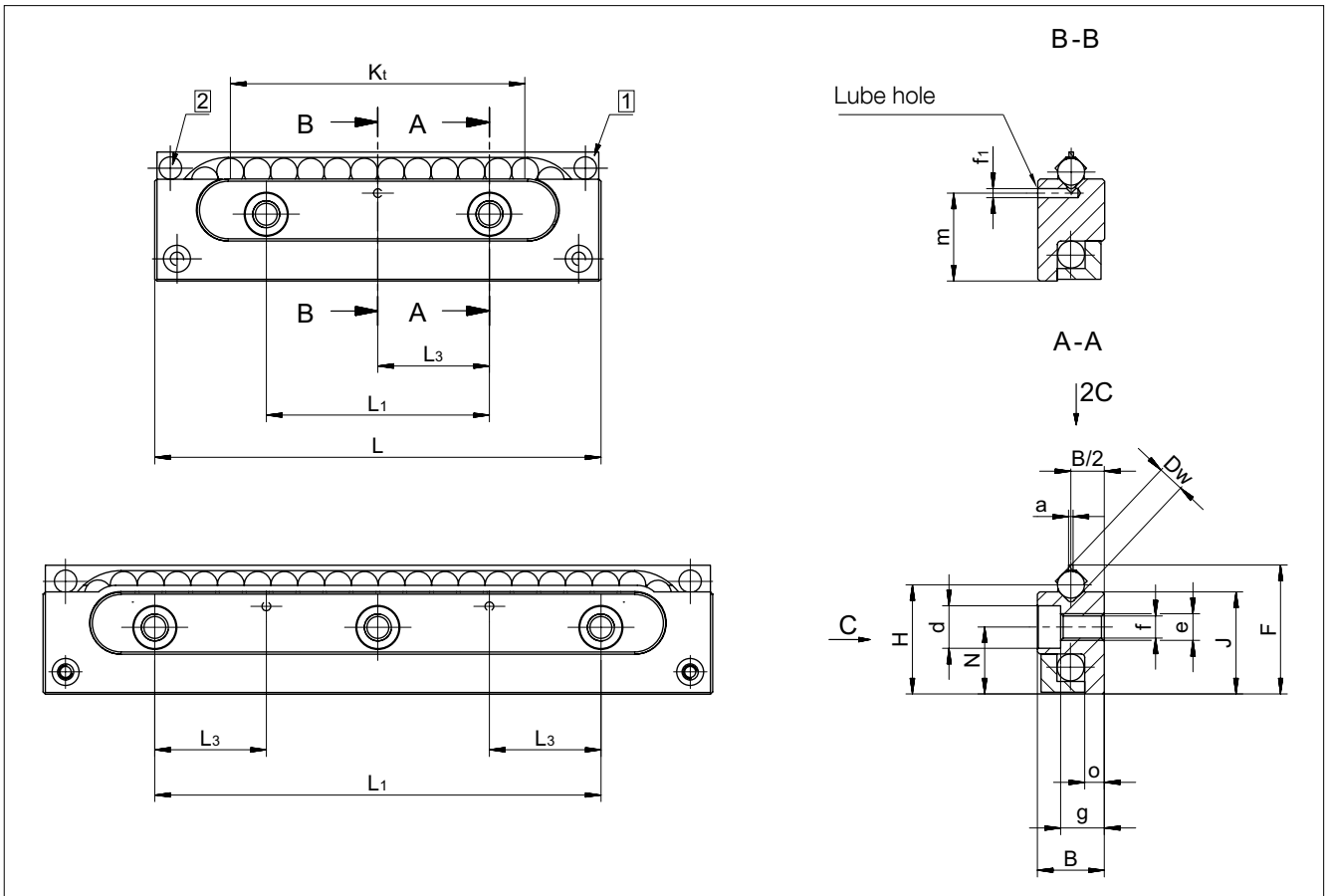

- 1 Retaining web may not be used as a stop
- 2 Wiper from size SK 3-075

Type and size	Weight in g	B	Dw	F	H	J	K ₁	L	L ₁	L ₃	N	a	d	e	f	f ₁	g	m	o	C in N		Options (see chapter 8)	
		SK	SKD	SK	SKD	SK	SKD	SK	SKD	SK	SKD	SK	SKD	SK	SKD	SK	SKD	SK	SKD	SK	SKD		
SK 1-022	5	4	1.5	8.4	7.25	6.9	9	22	10	-	4.8	0.3	3	M2	1.65	-	2.6	-	1.2	63		GP	
SK 2-032	10	6	2	11	9.5	9	16	32	15	-	6	0.3	4.4	M3	2.55	-	4	-	1.9	135		GP	
SK 3-075	45	8	3	16.9	14.5	13.8	48	75	25	12.5	9	0.5	6	M4	3.3	1.5	4.9	11.5	2.4	425		GP	
SK 6-100	SKD 6-100	200	15	6	28.9	24.5	22.9	60	100	50	25	15	1	9.5	M6	5.2	2	9.8	19.7	4.4	715	650	GP
SK 6-150	SKD 6-150	300						102	150	2 x 50											1'170	1'100	
SK 9-150	SKD 9-150	670	22	9	45.1	39	36.7	90	150	100	50	26	1.5	10.5	M8	6.8	3	15.8	32.4	6.3	1'650	1'500	GP
SK 9-200	SKD 9-200	940						144	200												2'550	2'400	
SK 12-200	SKD 12-200	1'470	28	12	57.1	49	45.9	120	200	100	50	32	2	13.5	M10	8.5	3	19.8	40.2	7.7	2'860	2'600	GP

The types in bold are standard. Types SK12 and SKD 12 are available on request

6 Recirculating unit

Installed dimensions and permissible torque for type SK and SKD

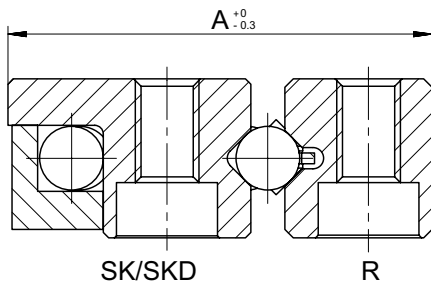

Installed dimensions for type SK and SKD

Type	Size	A	A ₁	e ₁
SK	1-022	11.5	28	M1.6
	2-032	15.5	37	M2.5
	3-075	23.5	57	M3
SK and SKD	6-100	40	94	M5
	6-150	40	94	M5
	9-150	61	150	M6
	9-200	61	150	M6
SK and SKD	12-200	78	175	M8

The types in bold are standard. Types SK12 and SKD 12 are available on request

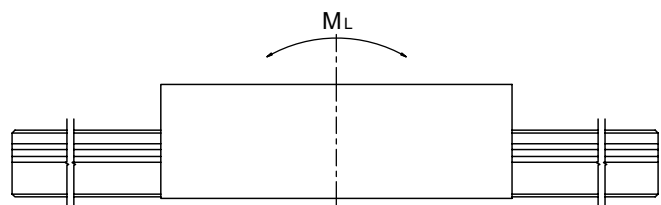
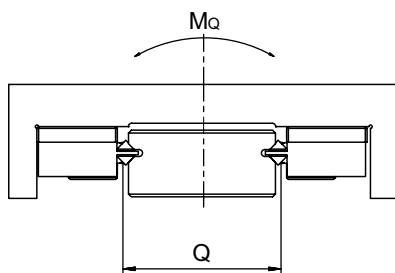
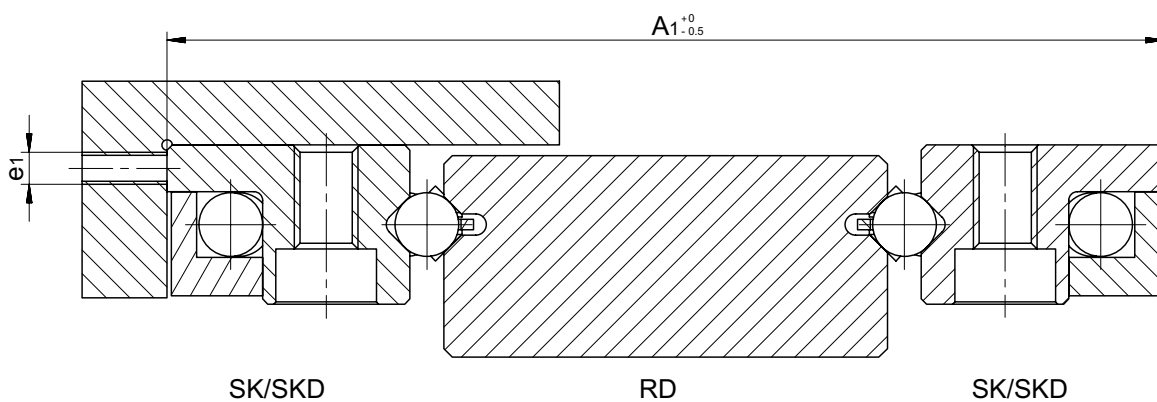

Permissible torques for type SK and SKD

Type	Size	Q	M _L in Nm		M ₀ in Nm	
			SK	SKD	SK	SKD
SK	1-023	13.5	0.4		0.8	
	2-033	18.0	1.4		2.4	
	3-076	28.0	7.2		12.0	
SK and SKD	6-100	45.0	23.0	23.0	32.0	29.0
	6-150		40.0	40.0	53.0	50.0
	9-150	72.0	81.0	81.0	119.0	108.0
			130.0	130.0	184.0	173.0
SK and SKD	12-200	77.0	187.0	187.0	220.0	200.0

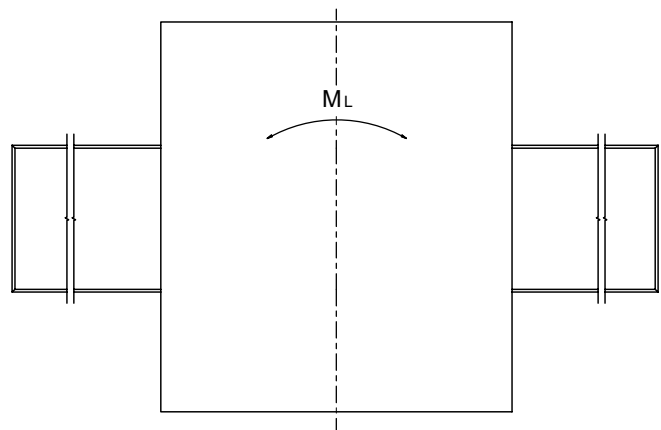

The types in bold are standard. Types SK12 and SKD 12 are available on request

6 Recirculating unit

6.2 Type SKC



The recirculating unit type SKC was developed for dry running, vacuum and clean room applications. It is made out of DURALLOY® coated steel and has ceramic balls, which are separated from one another by balls made out of TEFLON®.

This recirculating unit is used combined with SCHNEEBERGER linear guideways of type R and/or RD. The SKC units can be used in space saving designs that have equal loading in all directions. It is suitable for small to medium loads.

Benchmark data

Supporting structure

- Hardened and ground and coated with high precision

Materials

- Supporting structure made of stainless steel 1.4034, DURALLOY® coated, hardness min. 54 HRC
- Transmission part made out of stainless steel 1.4034
- Rolling element made of ceramic
(balls made of TEFLON® between the ceramic balls are responsible for minimal friction)

Speed

- 2 m/s

Acceleration

- 50 m/s²

Operating temperatures

- -150° C to +200° C

Same installation with the following recirculating units

- SK, SKD and SR

Can be combined with the following products

- Linear guideway type R and RD

6 Recirculating unit

Dimensions and load capacities of type SKC

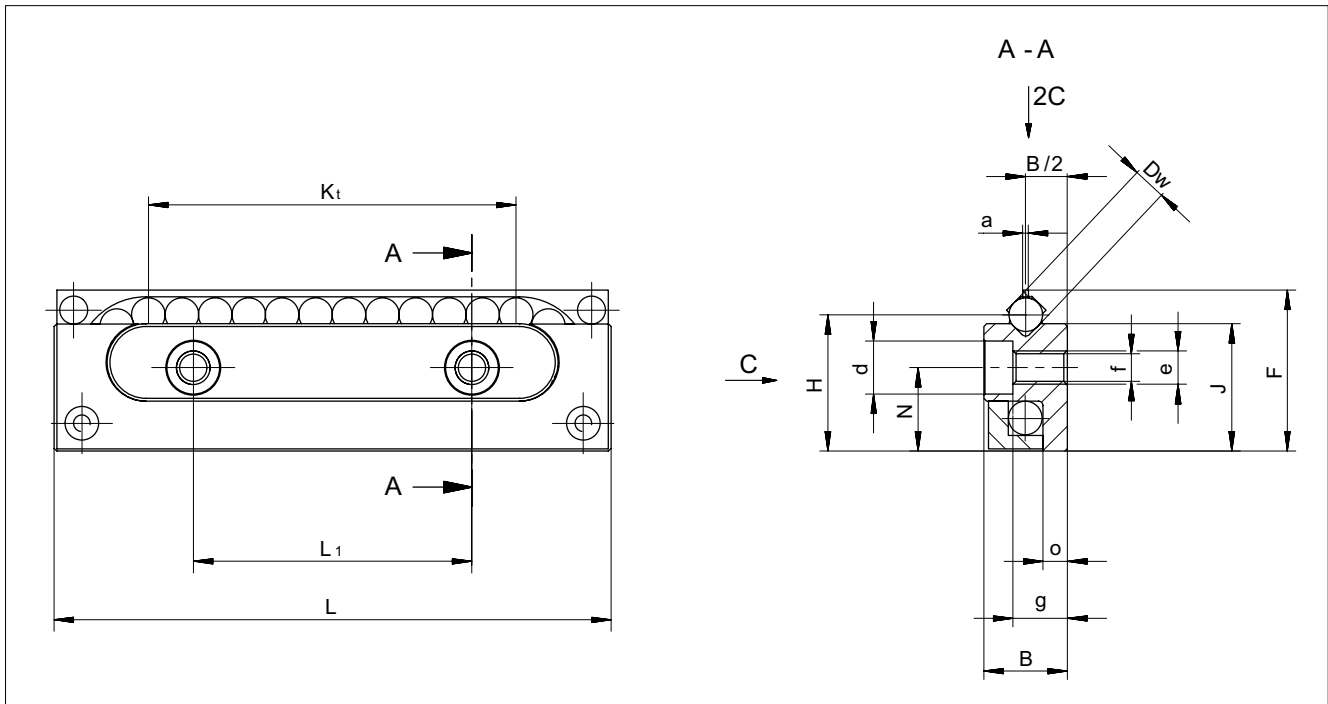

Type and size	Weight in g	B	Dw	F	H	J	K_t	L	L_1	N	a	d	e	f	g	o	C* in N	Options (see chapter 8)
SKC 3-075	44	8	3	16.9	14.5	13.8	48	75	25	9	0.5	6	M4	3.3	4.9	2.4	75	GP
SKC 6-100	212	15	6	28.9	24.5	22.9	60	100	50	15	1	9.5	M6	5.2	9.8	4.4	125	GP

* Loading capacity for dry running

6 Recirculating unit

Installed dimensions and permissible torques for type SKC

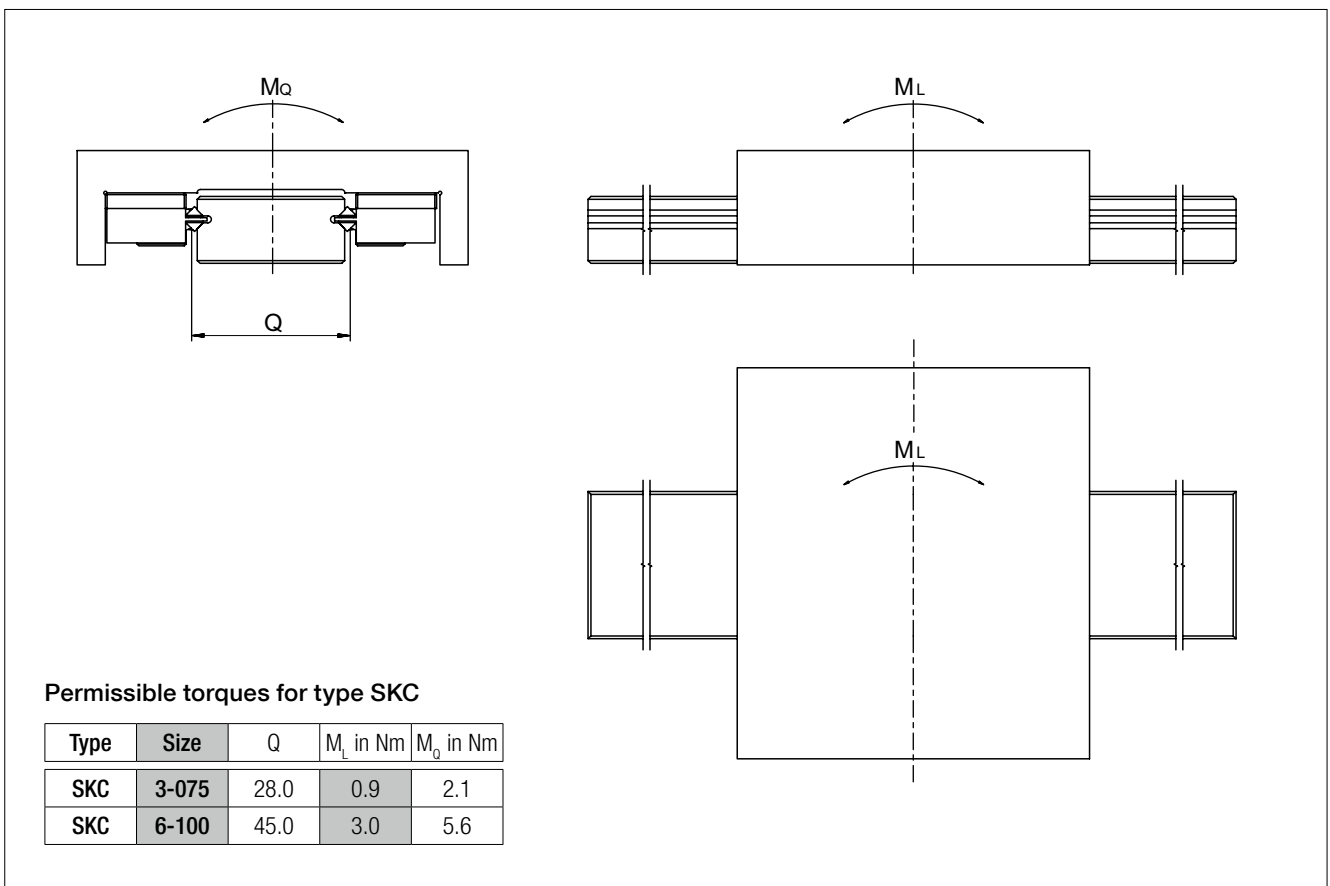
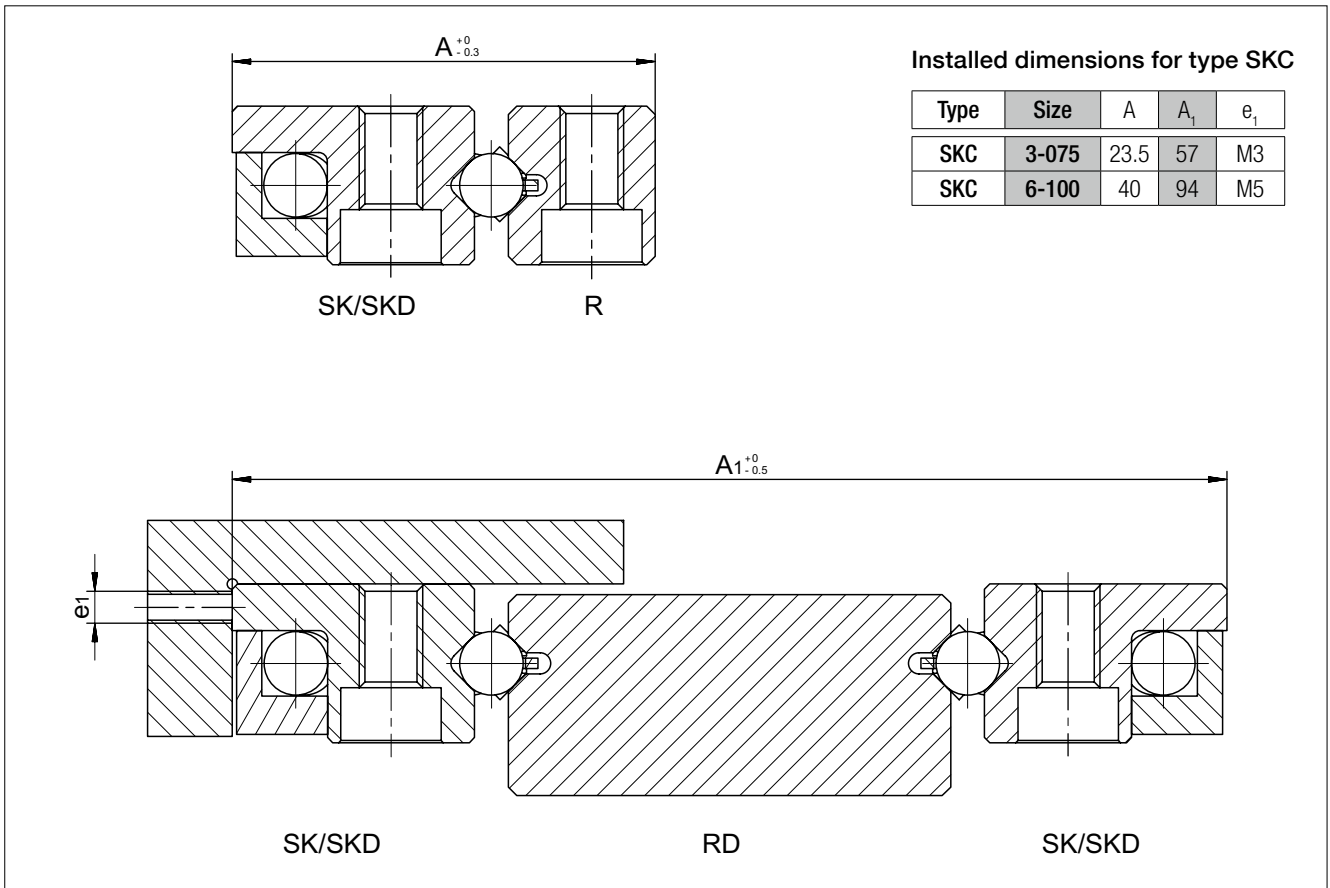

6 Recirculating unit

6.3 Type SR



The SR recirculating units has cross rollers and is suitable for medium to high loads.

This recirculating unit is used combined with SCHNEEBERGER linear guideways of type R and/or RD. In this way space-saving designs can be created that can be equally loaded in all directions.

Benchmark data

Supporting structure

- Hardened and ground with high precision

Materials

- Supporting structure made of through hardened tool steel, hardness 58 – 62 HRC
- Rolling element made of through hardened roller bearing steel, hardness 58 – 64 HRC
- Transmission part depending on the length made of plastic or anodized aluminium
- Stainless steel on request
- From size 3 the rollers are laid in plastic shoes

Speed

- 2 m/s

Acceleration

- 50 m/s²

Operating temperatures

- -40° C to +80° C

Same installation with the following recirculating units

- SK, SKD and SKC

Can be combined with the following products

- Linear guideway type R and RD

6 Recirculating unit

Dimensions and load capacities of type SR

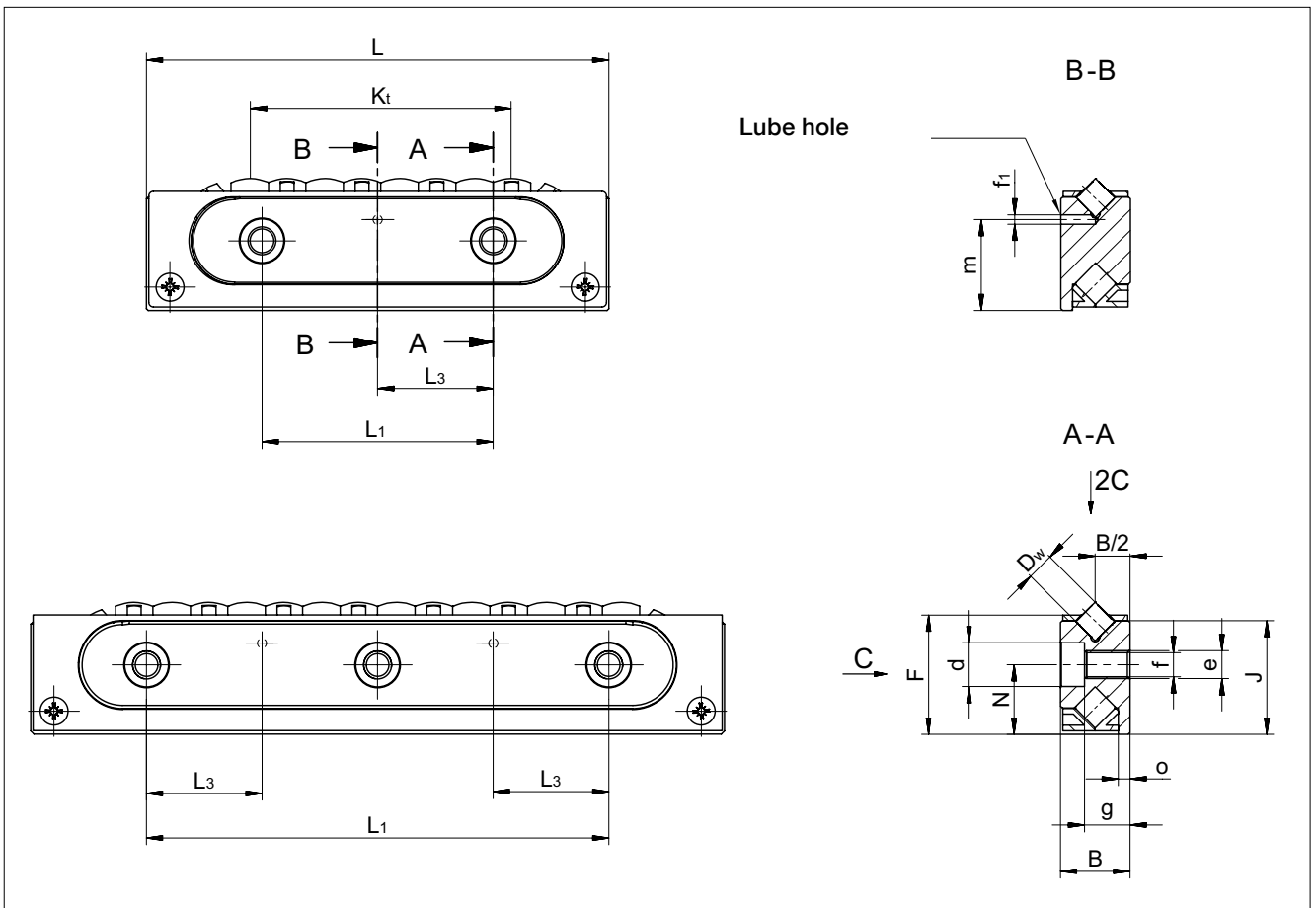

Type and size	Weight in g	B	Dw	F	J	K _t	L	L ₁	L ₃	N	d	e	f	f ₁	g	m	o	C in N	Options (see chapter 8)
SR 2-032	10	6	2	9.8	9.5	16	32	15	-	6	4.4	M3	2.55	-	4	-	1	380	GP
SR 3-075	50	8	3	15	14.5	46	75	25	12.5	9	6	M4	3.3	1.5	4.9	11.8	1.3	850	GP
SR 6-100	210	15	6	25.7	24.5	56	100	50	25	15	9.5	M6	5.2	2	9.8	19.7	2.5	2'150	GP
SR 6-150	310					105	150	50										3'750	
SR 9-150	750	22	9	40.5	39	92	150	100	50	26	10.5	M8	6.8	3	15.8	32.4	3.5	5'850	GP
SR 12-200	1'580	28	12	51.5	49	112	200	100	50	32	13.5	M10	8.5	3	19.8	40.2	4	10'000	GP

The types in bold are standard. Type SR 12 is available on request

6 Recirculating unit

Installed dimensions and permissible torques for type SR

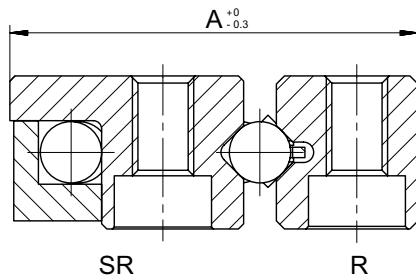

Installed dimensions for type SR

Type and size	A	A ₁	e ₁
SR 2-032	15.5	37	M2.5
SR 3-075	23.5	57	M3
SR 6-100	40	94	M5
SR 6-150	40	94	M5
SR 9-150	61	150	M6
SR 12-200	78	175	M8

The types in bold are standard. Type SR 12 is available on request

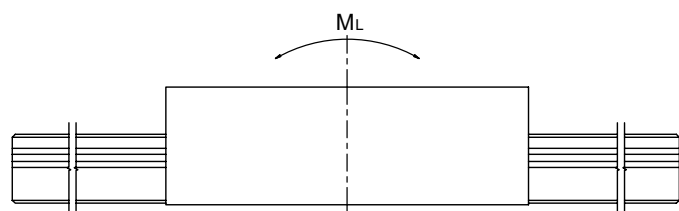
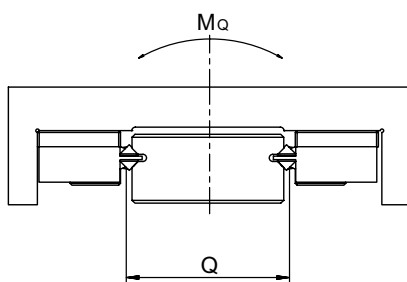
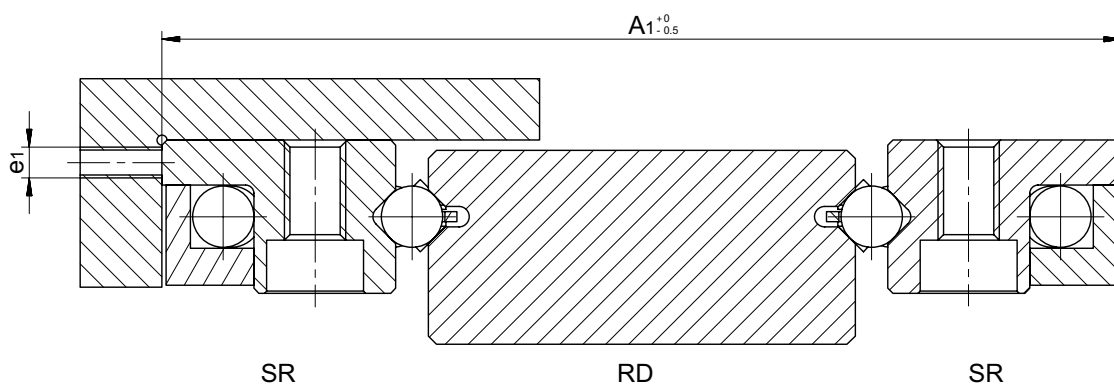

Torques for type SR

Type and size	Q	M _L in Nm	M _Q in Nm
SR 2-032	18.0	3.0	7.0
SR 3-075	28.0	12.0	24.0
SR 6-100	45.0	60.0	97.0
SR 6-150		112.0	169.0
SR 9-150	72.0	241.0	421.0
SR 12-200	77.0	553.0	770.0

The types in bold are standard. Type SR 12 is available on request

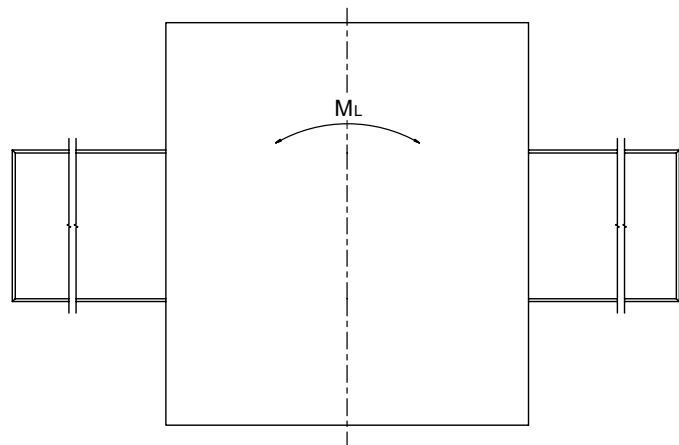

6 Recirculating unit

6.4 Type NRT (with NRV)



Recirculating unit type NRT

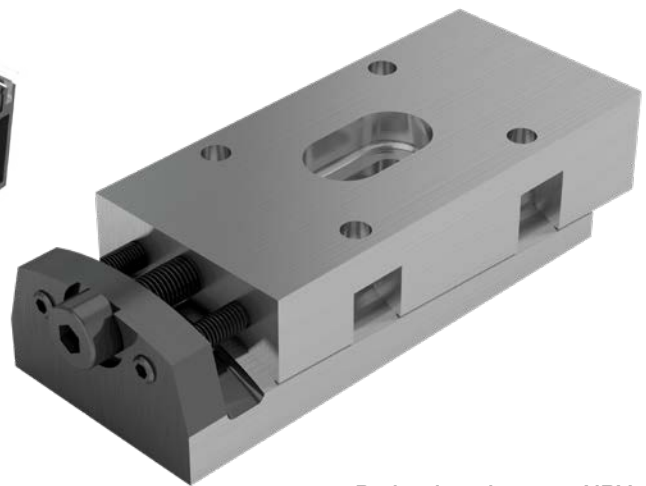

Preload wedge type NRV

This roller recirculating unit is designed for medium to heavy loads. Solutions to demanding applications can be created using NRT, NRV, and suitable guideways.

Advantages/benefits of the NRT

- Two independent tracks, the small amount of roller play and the optimal ratio of roller length and roller diameter are responsible for minimal lateral forces.
- The large number of rollers and the optimised roller run-ins are responsible for minimal travel pulsation and a low coefficient of rolling friction
- High degree of rigidity thanks to three-point support on the rear
- Protected roller return
- Double-lipped wipers on each side
- Can also be supplied matched as an option, sorted within 5µm

Advantages/benefits of the preload wedge NRV

This preload wedge is used for setting preload. The NRV with its concave and convex supporting surfaces is also able to even out minor angular errors and deformations in the connecting structure.

Benchmark data

Supporting structure

- Hardened and ground with high precision

Materials

- Supporting structure made of through hardened tool steel, hardness 58 – 62 HRC
- Rolling element made of through hardened roller bearing steel, hardness 58 – 64 HRC
- Transmission parts and wipers made of plastic

Speed

- 1 m/s

Acceleration

- 50 m/s²

Operating temperatures

- -40° C to +80° C

6 Recirculating unit

Dimensions and load capacities of type NRT

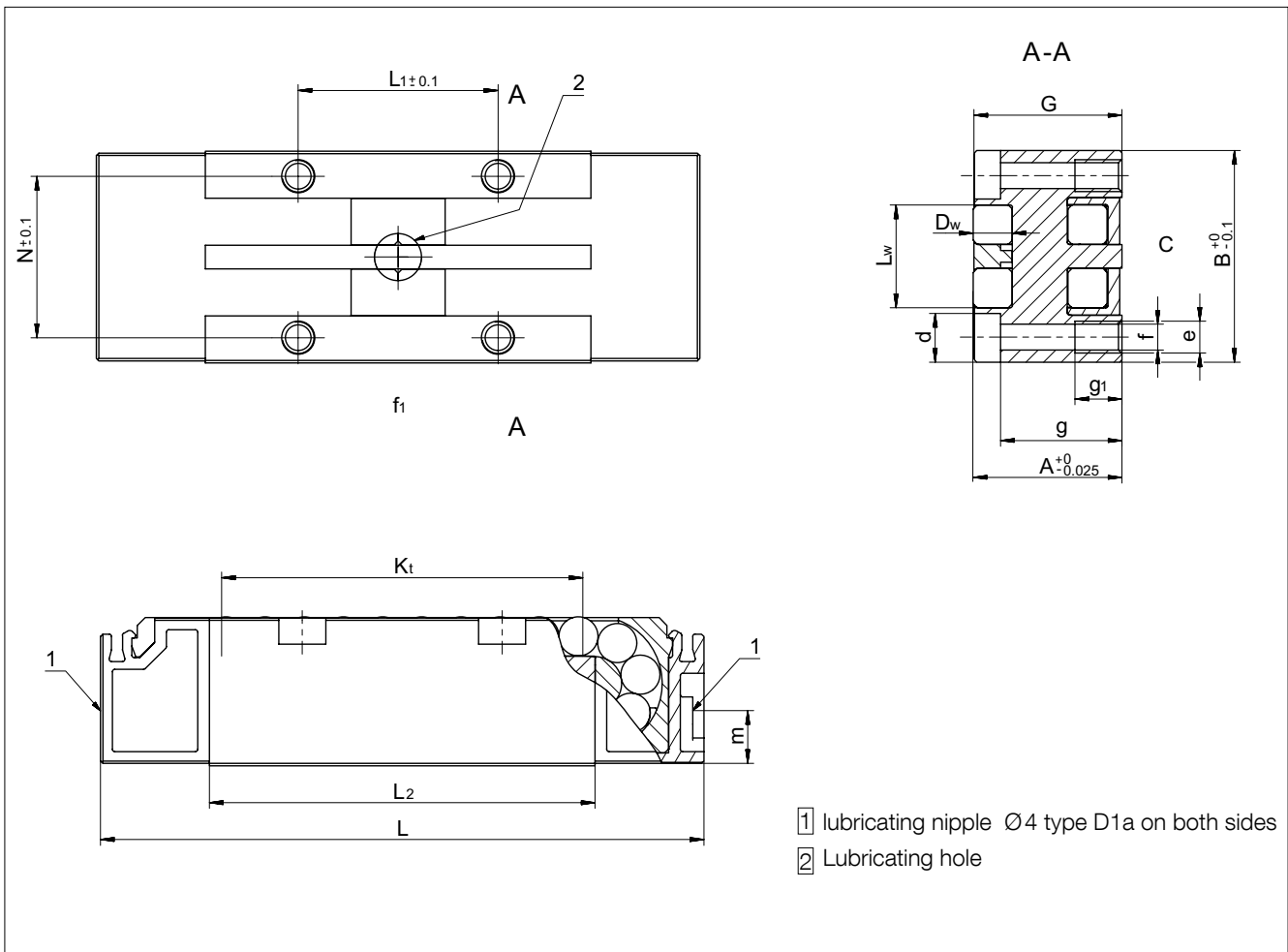

Recirculating unit type NRT

Type and size	Weight in g	A	B	Dw	G	K_t	L	L_1	L_2	L_w	N	d	e	f	f_1	g	g_1	m	C in N	Options (see chapter 8)
NRT 19077	185	19	27	5	18.85	45	77	25.5	49.2	13	20.6	6	M4	3.3	6	15.5	6	5.3	43'000	GP ZS
NRT 26111	570	26	40	7	25.85	70	111	44	75.6	19	30	8	M6	5	9	20	10	10.3	98'000	GP ZS
NRT 26132	721					91	132	68	96.6							20.6			120'000	GP ZS
NRT 38144	1'390	38	52	10	37.8	90	144	51	96.8	26	41	11	M8	6.8	11	29	14	14.5	181'000	GP ZS

6 Recirculating unit

Dimensions and load capacities of type NRV

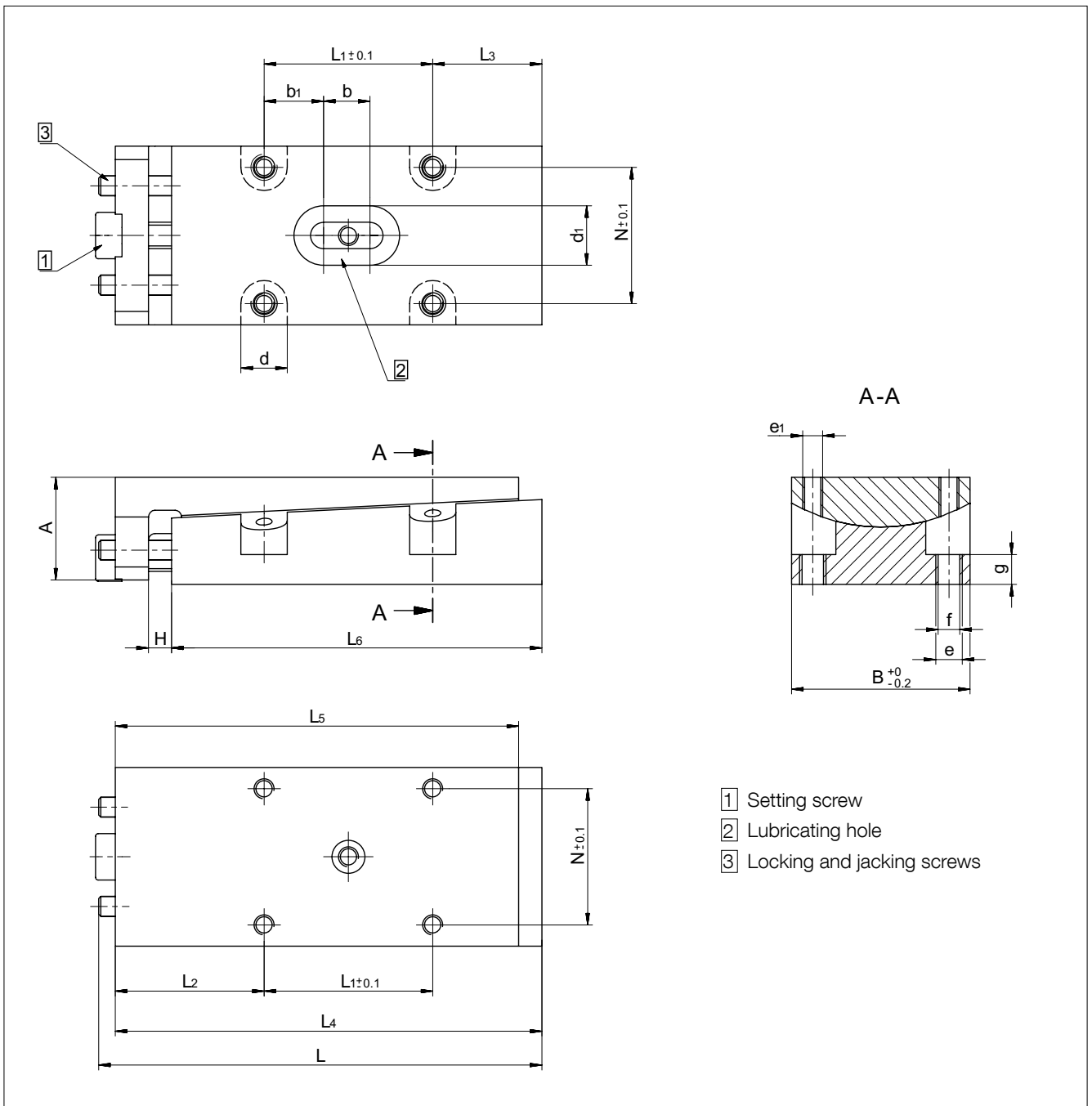

Preload wedge NRV

Type and size	Weight in g	A	B	H max.	L max.	L_1	L_2	L_3	L_4 max.	L_5	L_6	N	b	b_1	d	d_1	e	e_1	f	g
NRV 19077	195	16	27	7	72	25.5	22.5	16.5	68	61	56	20.6	7	9	7	9	M4	M3	3.3	4.5
NRV 26111	670	25	40	8	105	44	29	21	98	90	83	30	9	17.5	8	11	M6	M4	5	8
NRV 26132	837				126	68	27.5	19.5	119	111	104			29.5						
NRV 38144	1'300	30	52	8	130	51	37.5	28.5	121	113	105	41	10	20.5	11	14	M8	M6	6.8	8

7 Options for linear guideways

7.1 Quality classes (SQ and SSQ)

Depending upon the application different levels of accuracy are required. SCHNEEBERGER linear guideways are available in three quality classes to address a variety of applications:

NQ*	Normal quality	Represents normal requirements in mechanical engineering
SQ	Special quality	In case of very stringent requirements
SSQ	Super special quality	In case of the most stringent requirements

Note:

*NQ represents standard quality and is not subsequently listed as an order code

The corresponding tolerance values (Δ) for parallelism of the running surfaces in relation to the reference and locating surfaces can be seen in the diagram below.

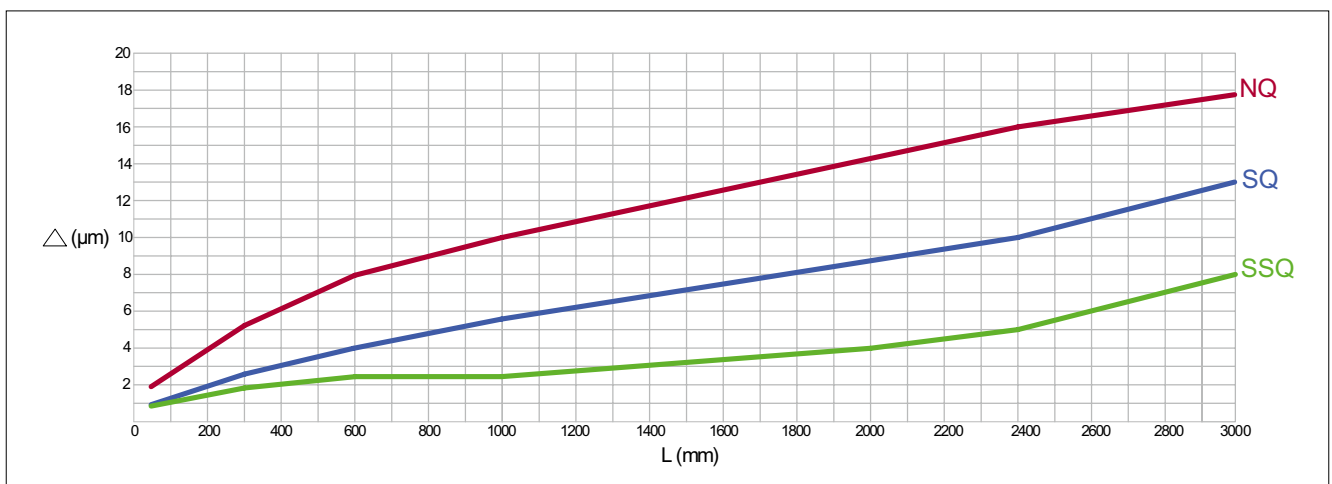

In terms of the quality classes SQ and SSQ the following limitations technically exist:

- Max. lengths according to the table „Dimensions and load capacities“ of the respective product.
- Coatings (see chapter 7.6 and 7.7).

7.2 Guideways made of corrosion-resistant steel (RF)

For certain applications such as, for example, medical technology, food industry or in a vacuum, the guide rails can be made of corrosion-resistant steel.

Notes:

- The max. rail length in normal quality as well as in options SQ and SSQ is limited (see „dimensions and load capacities“ of the respective product).
- The hardness of the steel reduces compared with tool steel to min. 54 HRC, which should be taken into account in the food calculation.

7 Options for linear guideways

7.3 Run-ins rounded (EG)

Overrunning cages are expedient to be used if a short table is to be moved on a long guideway track. As a result the upper part is at any time supported over its entire length, which has a positive effect on the load carrying capacity and rigidity.

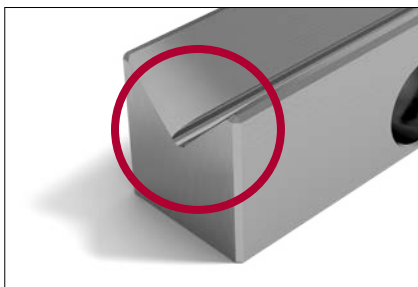
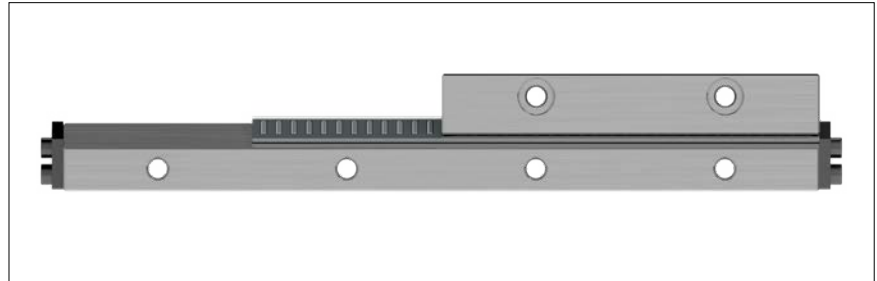

So that the cage run-in causes as little pulsation as possible, the short rails are provided with rounded run-ins. The run-ins are ground following manufacture of the guideway track.

Note:

On rare occasions (e.g. under very high preload), in spite of rounded run-ins the pulsation of the overrunning cage can have a disruptive effect on the application. This phenomenon can be largely eliminated by taking appropriate measures (on request).

7.4 Multi-part linear guideways (ZG)

If the desired overall length of the guideway is greater than the maximum length listed in this catalogue, individual rails can be ground together. The offset between the individual guideway tracks for this is max. 0.002 mm. The length tolerance L is within +/- 2 mm.

During installation it is important to pay attention to the numbering at the butt joint.

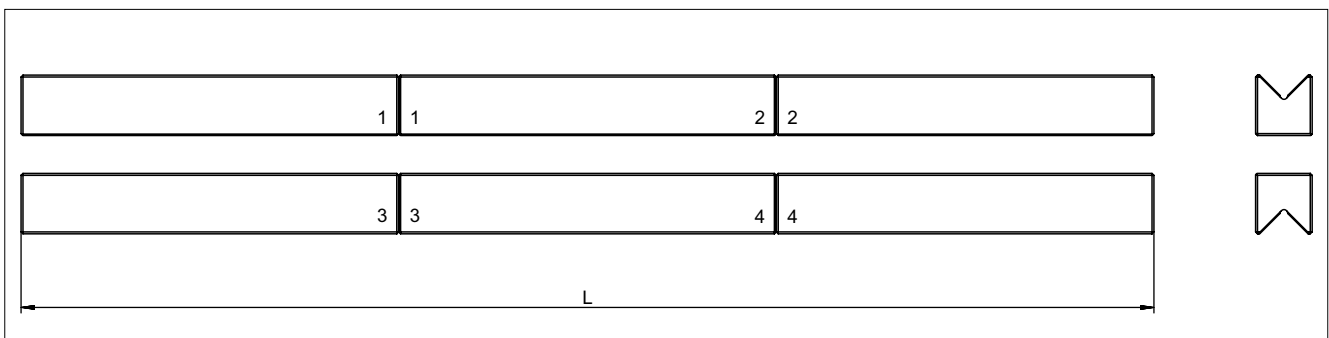

7 Options for linear guideways

7.5 Height-matched guideways (HA)

The tolerance of height A is as standard 0/-0.3 mm. In the case of surface-mounted guideways, which must be matched to the same height, A (and/or A_1 and A_2) is made in consignments with a tolerance of +/- 0.01 mm.

The rails are identified/numbered correspondingly. If multiple consignments are supplied, they are given serial numbers.

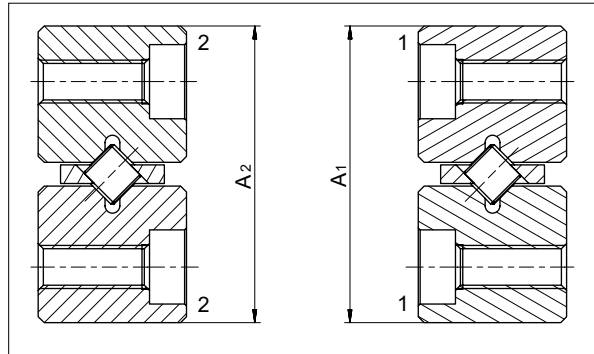

7.6 DURALLOY® coating (DU)

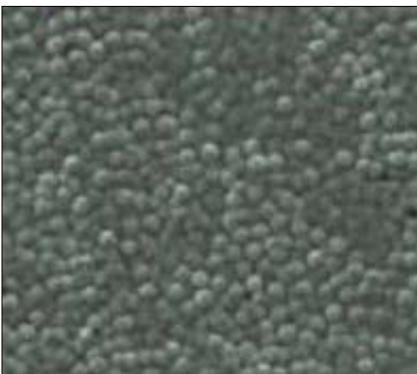

For applications in which a corrosion protection and/or increased wear resistance of the surfaces is required, it is recommended to coat the guideways with DURALLOY®.

Technical information

- Max. rail length 3000 mm
- Hardness HRC 64 - 74
- Coating thickness 2.5 - 4.0 μm
- Structure "Pearlescent" (see figure)
- Vacuum-compatible 10^{-7} mbar

The advantages of DURALLOY®

- Increased wear resistance
- Corrosion protection
- The pearl structure acts as a lubricant reservoir
- Good emergency running characteristics
- Protection from abrasive corrosion
- High degree of chemical resistance

Notes:

- The ZG special versions (multi-part linear guideway) and the maximum quality grade SSQ are not possible.
- Special quality SQ only on request

7 Options for linear guideways

7.7 DryRunner coating (DR and DRC1)

Without lubrication the running surfaces of linear guideways are completely destroyed after only 10'000 passes.

A guideway coated with DryRunner supports more than 100 million passes and thus a service life extended by 10'000 times - without lubrication. In vacuum an unlubricated guideway coated with DryRunner supports more than 50 million passes.

DryRunner coated linear guideways can of course be used with standard lubricants, which means the previously listed running performance statistics increase considerably.

Technical information

Area of use	Order code	Film thickness	Max. length of the guideway
Air	DR	1.5–3.0 µm	900 mm
Vacuum (up to 10 ⁻⁷ mbar)	DRC1	1.0–2.0 µm	900 mm

- The coating is only applied to the running surfaces. From a production technology standpoint, it is possible that other exterior surfaces are coated; but not the supporting and locating surface of the guideway.
- DryRunner does not provide any protection against corrosion. If corrosion resistance is required, the guideway must be ordered in a non-corrosive material.

The advantages of DryRunner

- Supports dry running
- Suitable for applications in air or vacuum
- Minimal wear as a result of abrasion

Notes

- DryRunner supports operation without a lubricant, which is why we recommend the use of the cage control FORMULA-S (KS) option (see chapter 7.8).
- The special versions of multi-part linear guideways ZG and the quality class SSQ are not possible. Quality class SQ on request (see chapter 7.4 and 7.1).

7 Options for linear guideways

7.8 Cage control FORMULA-S (KS)

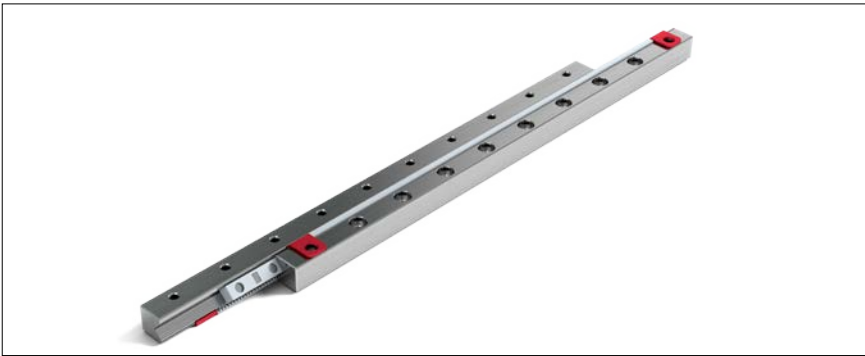

In every linear guideway the cage can be shifted from the centre along the longitudinal axis. Cage creep reduces the optimal load distribution and requires a correct stroke to return the cage to a centered position. The correction stroke requires a large expense of energy.

The causes of cage creep

- High accelerations and speeds
- Vertical installation of the guideway
- Uneven load distribution
- Protruding cage
- Different heat expansion coefficients
- Design and installation (lacking rigidity and/or accuracy of the connecting structure)

The benefits and advantages of FORMULA-S

- Perfect load distribution
- Avoids correction strokes
- No force required for cage reset
- Accelerations up to 300 m/s^2 (30 g)
- Max speed 1 m/s
- Easy to install and/or uninstall
- Extended service life
- Vacuum-compatible up to 10^{-7} mbar

Suitable for the following guideways

- RN 3, RN 4 and RN 6
- RNG 4, RNG 6 and RNG 9

FORMULA-S meets the requirements fully in respect of productivity and cost-effectiveness. It is very robust and consists of only a few components.

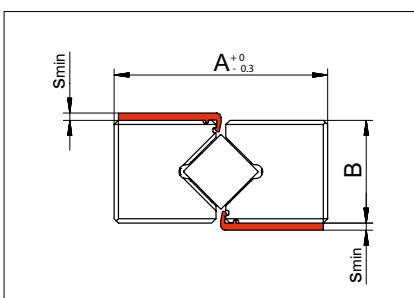
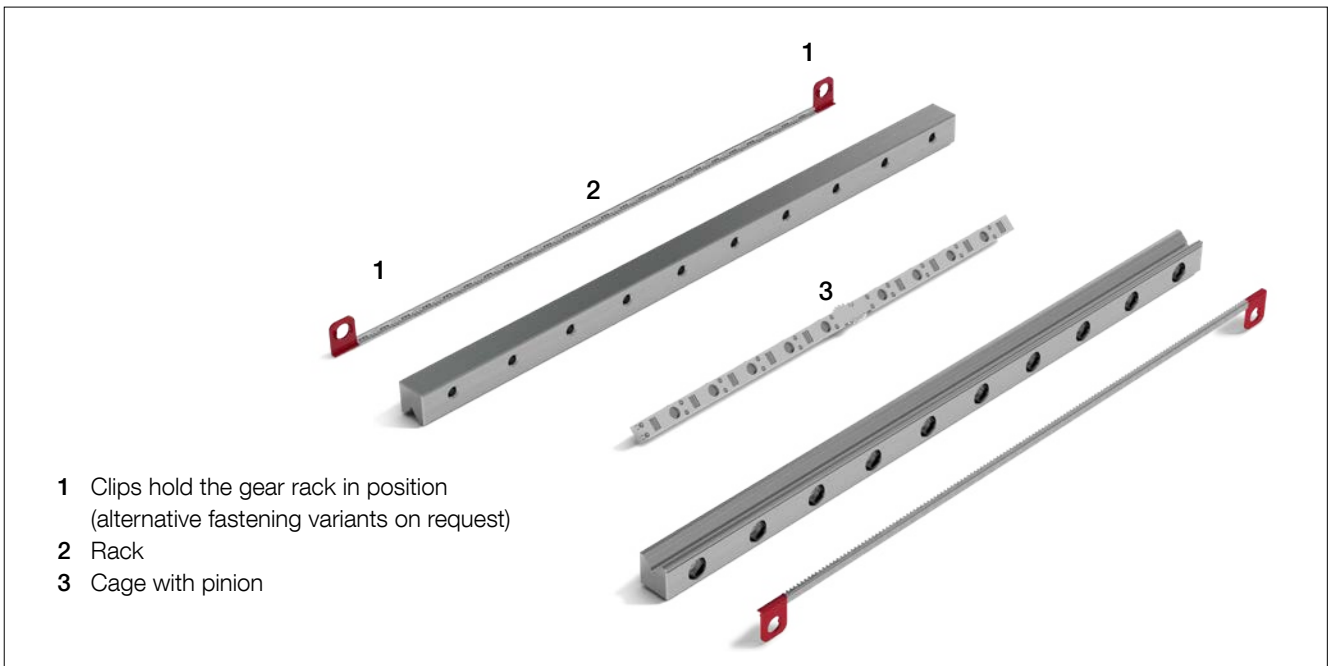

Connecting structure

In the case of the connecting structure, the thickness S_{\min} should be taken into account. The remaining dimensions correspond to the guideways RN and RNG (see chapter 5, dimensions and load capacities).

7 Options for linear guideways

7.9 Cage control for N/O and M/V guideways (KZST)

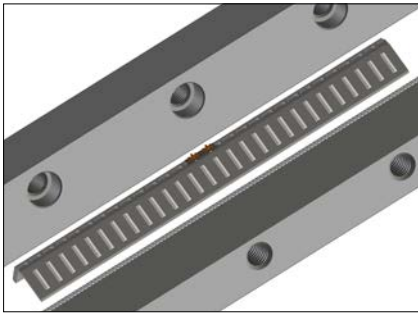

The needle guideways of type N/O and M/V can be fitted with a cage control which ensures that process security is significantly increased. The causes and effects of cage creep are set out in chapter 7.8.

The benefits and advantages

- Perfect load distribution
- Avoids correction strokes
- No force required for cage reset
- Accelerations up to 200 m/s^2 (20 g)
- Max. speed 1 m/s
- Extended service life

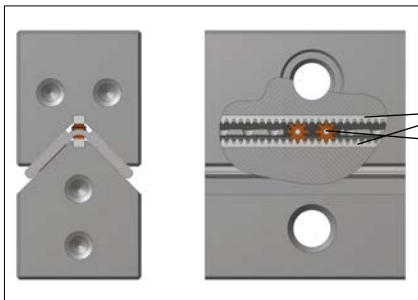

This type of cage control fully meets the requirements in terms of productivity and cost-effectiveness. It is very robust, has a simple structure and consists of only a few components:

- A** A gear rack made of tool steel per guide rail
- B** Two pinions made of tool steel per cage

7.10 Fixing Hole Variants (V, G, or D)

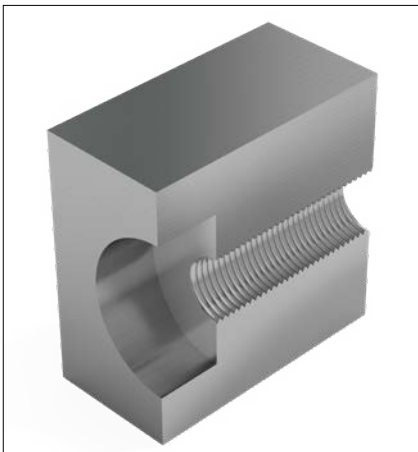

The SCHNEEBERGER standard

All SCHNEEBERGER guideways have as standard a counterbore with thread (not suitable for linear guideways of type M/V). This design supports the use of a tapped fixing hole as well as the through fixing hole. The dimensions can be seen in the respective product specifications (chapter 5).

7 Options for linear guideways

Special versions type V (standard for linear guideway of type M/V)

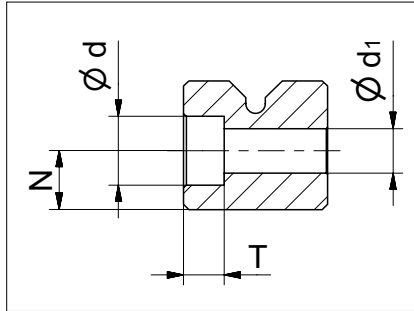
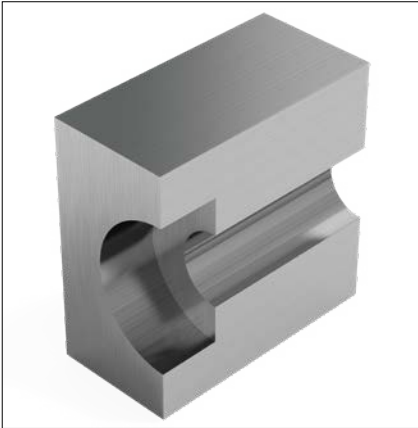

Dimensions for R-guideways

Type	N	Ø d	T	Ø d ₁
R 1	1.8	3	1.4	1.65
R 2	2.5	4.4	2	2.55
R 3	3.5	6	3.2	3.5
R 6	6	9.5	5.2	5.5
R 9	9	10.5	6.2	6.5
R 12	12	13.5	8.2	8.5
R 15	14	16.5	10.2	10.5
R 18	18	18.5	12.2	12.5
R 24	24	22.5	14.2	14.5

Dimensions for RN-guideways

Type	N	Ø d	T	Ø d ₁
RN 3	3.5	6	3.2	3.5
RN 4	4.5	8	4.1	4.5
RN 6	6	9.5	5.2	5.5
RN 9	9	10.5	6.2	6.5
RN 12	12	13.5	8.2	8.5
RN 15	14	16.5	10.2	10.5
RN 18	18	18.5	12.2	12.5
RN 24	24	22.5	14.2	14.5

Dimensions for RNG-guideways

Type	N	Ø d	T	Ø d ₁
RNG 4	3.5	6	3.2	3.5
RNG 6	5	7	3.2	4
RNG 9	6	8.5	4.2	4.8
RNG 12	8	12	6.2	7
RNG 15	10	15	8.2	9
RNG 20	12	18	11	10.5

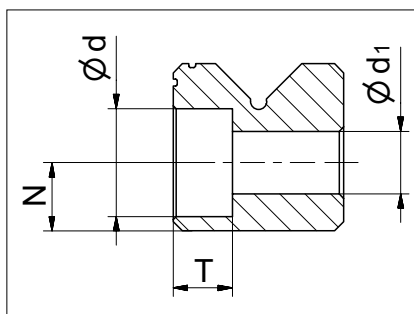

Dimensions for RNG guideways with a cage control system (KS)

Type	N	Ø d	T	Ø d ₁
RNG 4-KS	3.5	6	3.2	3.5
RNG 6-KS	5	7.8	3.5	3.8
RNG 9-KS	6	8.5	4.2	4.8

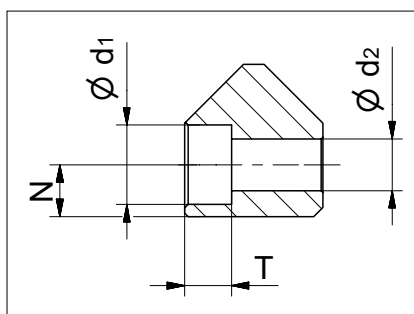
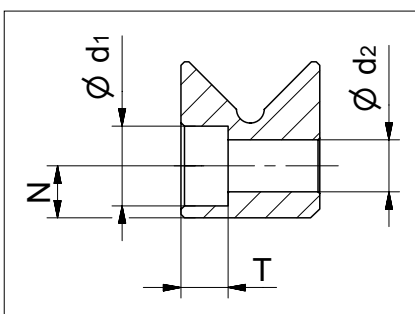

Dimensions for N/O-guideways

Type	N	Ø d ₁	T	Ø d ₂
N/O 62015	6	9.5	5.2	5.5
N/O 92025	9	10.5	6.2	6.8
N/O 2025	10	13.5	8.2	8.5
N/O 2535	12	16.5	10.2	10.5
N/O 3045	14	18.5	12.2	12.5
N/O 3555	14	18.5	12.2	12.5

7 Options for linear guideways

Special versions type G

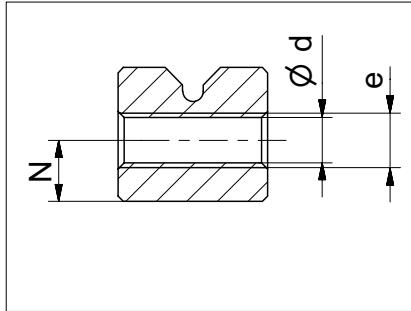
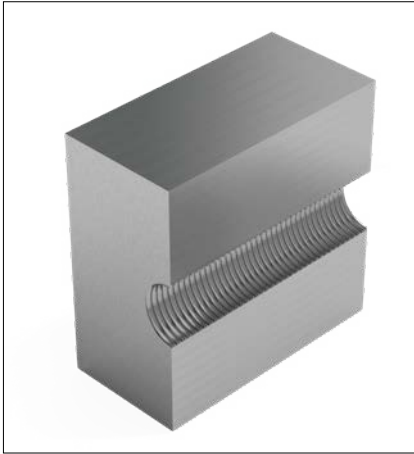

Dimensions for R-guideways

Type	N	e	Ø d
R 1	1.8	M2	1.65
R 2	2.5	M3	2.55
R 3	3.5	M4	3.3
R 6	6	M6	5.2
R 9	9	M8	6.8
R 12	12	M10	8.5
R 15	14	M12	10.5
R 18	18	M14	12.5
R 24	24	M16	14.5

Dimensions for RN-guideways

Type	N	e	Ø d
RN 3	3.5	M4	3.3
RN 4	4.5	M5	4.3
RN 6	6	M6	5.2
RN 9	9	M8	6.8
RN 12	12	M10	8.5
RN 15	14	M12	10.5
RN 18	18	M14	12.5
RN 24	24	M16	14.5

Dimensions for RNG-guideways

Type	N	e	Ø d
RNG 4	3.5	M3	2.65
RNG 6	5	M4	3.3
RNG 9	6	M5	4.4
RNG 12	8	M8	6.8
RNG 15	10	M10	8.5
RNG 20	12	M12	10.5

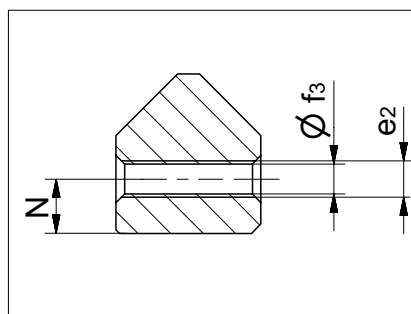
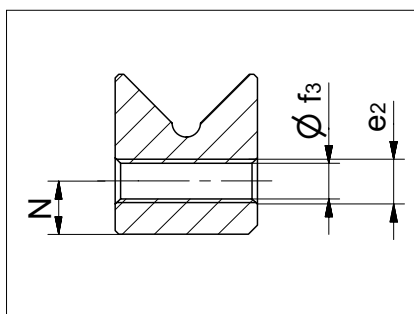

Dimensions for N/O-guideways

Type	N	e ₂	Ø f ₃
N/O 62015	6	M6	5.2
N/O 92025	9	M8	6.8
N/O 2025	10	M10	8.5
N/O 2535	12	M12	10.5
N/O 3045	14	M14	12.5
N/O 3555	14	M14	12.5

7 Options for linear guideways

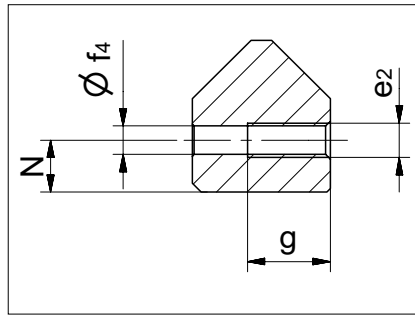
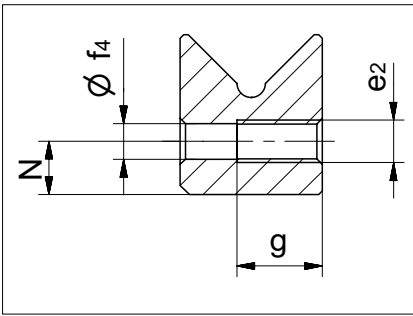
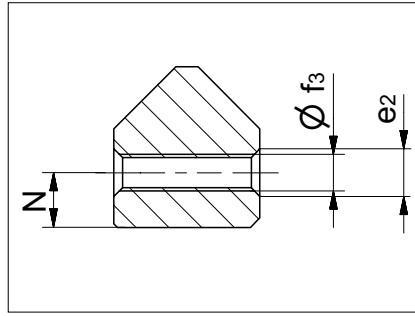
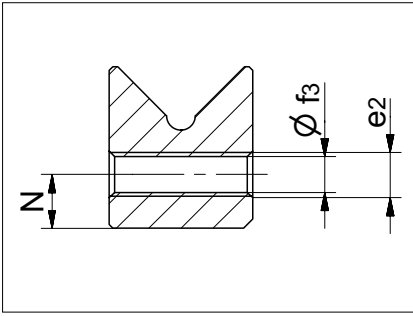

Dimensions for M/V-guideways

Type	N	e ₂	g	Ø f ₃	Ø f ₄
M/V 3015	5.5	M4	-	3.2	-
M/V 4020	7.5	M6	-	5.2	-
M/V 5025	10	M6	15	5.2	5
M/V 6035	11	M8	20	6.8	6.8
M/V 7040	13	M10	25	8.5	8.5
M/V 8050	14	M12	30	10.5	10.3

7 Options for linear guideways

Special versions type D

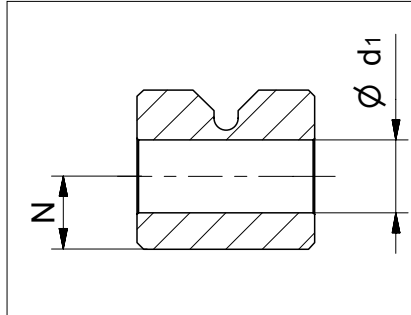
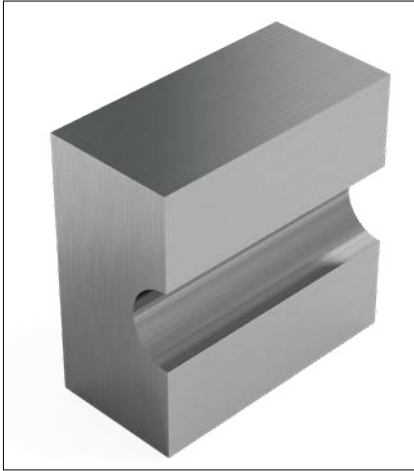

Dimensions for R-guideways

Type	N	Ø d ₁
R 1	1.8	1.65
R 2	2.5	2.55
R 3	3.5	3.5
R 6	6	5.5
R 9	9	6.5
R 12	12	8.5
R 15	14	10.5
R 18	18	12.5
R 24	24	14.5

Dimensions for RN-guideways

Type	N	Ø d ₁
RN 3	3.5	3.5
RN 4	4.5	4.5
RN 6	6	5.5
RN 9	9	6.5
RN 12	12	8.5
RN 15	14	10.5
RN 18	18	12.5
RN 24	24	14.5

Dimensions for RNG-guideways

Type	N	Ø d ₁
RNG 4	3.5	3.5
RNG 6	5	4
RNG 9	6	4.8
RNG 12	8	7
RNG 15	10	9
RNG 20	12	10.5

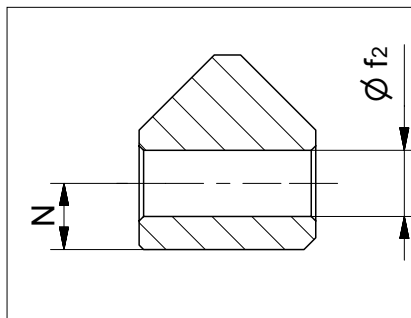
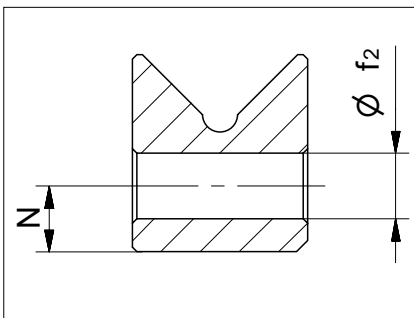

Dimensions for N/O-guideways

Type	N	Ø f ₂
N/O 62015	6	5.5
N/O 92025	9	6.5
N/O 2025	10	8.5
N/O 2535	12	10.5
N/O 3045	14	12.5
N/O 3555	14	12.5

Dimensions for M/V-guideways

Type	N	Ø f ₂
M/V 3015	5.5	5.3
M/V 4020	7.5	7.5
M/V 5025	10	7.5
M/V 6035	11	10
M/V 7040	13	12.5
M/V 8050	14	14

8 Recirculating unit options

8.1 Matched recirculating units (GP)

If two or more recirculating units are arranged next to or behind one another, they need to be ordered (matched in pairs) with the add-on designation GP.

SK, SKD, SKC, SR

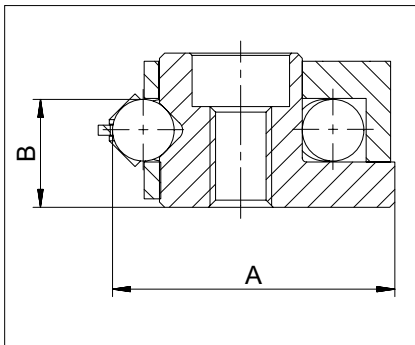

Type	Manufacturing tolerances in mm		Group tolerances in μm within pairs	
	A	B	A	B
SK 1, 2	0/-0.1	+/-0.005	2	2
SK 3, 6, 9, 12	0/-0.1	+/-0.005	3	3
SKD 6, 9, 12	0/-0.1	+/-0.005	3	3
SKC 6, 9	0/-0.1	+/-0.005	3	3
SR 2	0/-0.1	+/-0.005	2	2
SR 3, 6, 9, 12	0/-0.1	+/-0.005	3	3

The types in bold are standard. The types in size 12 are available on request

Markings:

The recirculating units in the same group are designated with a number, i.e. the same number corresponds to the exact same tolerance group.

NRT

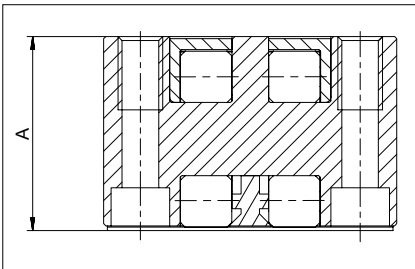

Type	Manufacturing tolerance A	Sorts in μm	Markings
NRT	-0.025	-20 to -25	white
		-15 to -20	green
		-10 to -15	yellow
		-5 to -10	blue
		0 to -5	red

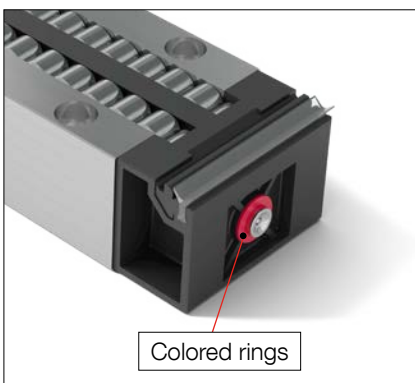

Markings:

Colored rings around the lube nipple mark the relevant tolerance group.

8 Recirculating unit options

8.2 Centralised lubricating system (ZS) for recirculating units NRT

Connection variants

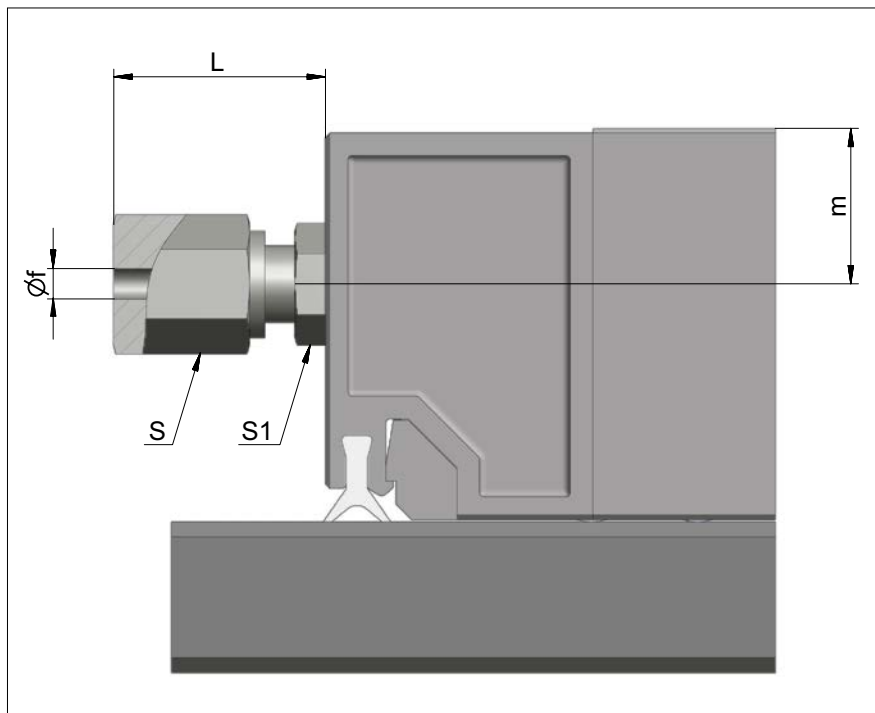

Type	Size	L	f	m	Wrench size	
					s	s1
NRT 19077	ZS-2	14	2	5.3	8	7
	ZS-3	16	3			
NRT 26111 NRT 26132	ZS-2	14	2	10.3	10	8
	ZS-3	16	3			
	ZS-4	20	4			
	ZS-5	20	5			
	ZS-6	22	6			
NRT 38144	ZS-2	14	2	14.5	12	10
	ZS-3	16	3			
	ZS-4	20	4			
	ZS-5	20	5			
	ZS-6	22	6			

9 Linear guideways standard parameters

9.1 Quality classes

The running and positioning accuracy of an application directly depends on the geometric precision of the guideway (see chapter 7.1), its careful orientation (see chapter 14.9) and the accuracy and rigidity of the surrounding structure (see chapter 14.1 / 14.2).

9.2 Tolerance of the supporting surface to the track

In addition to the previously mentioned geometric precision as set out in chapter 7.1, SCHNEEBERGER guideways are also manufactured to the dimensions of the supporting surface in relation to the track within a very tight tolerance ($\pm 0.005\text{mm}$).

Advantages:

- Interchangeability is guaranteed at all times.
- In most cases additional matching of the guideways is surplus to requirement.

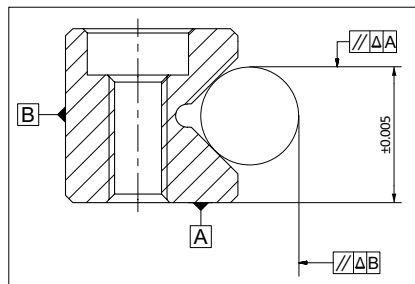

Type R, RN and RNG

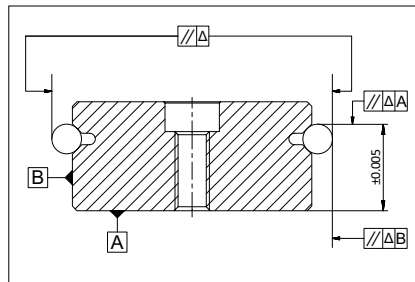

Type RD

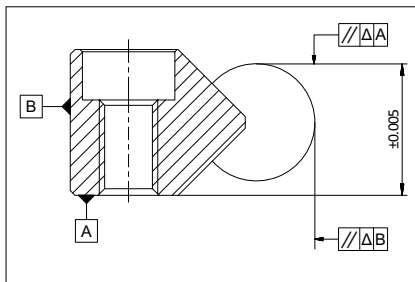

Type N/O and M/V

9 Linear guideways standard parameters

9.3 Length tolerances and distances between fixing holes

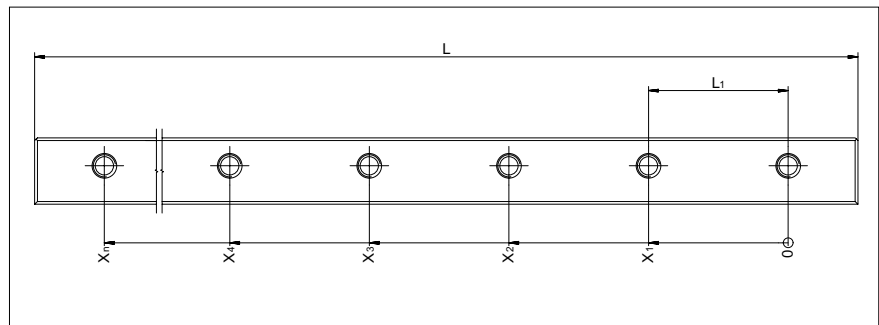

Length	$L \leq 300$ mm:	± 0.3 mm
Length	$L > 300$ mm:	± 0.1 % of L
Hole pitch	L_1 :	± 0.3 mm
Mass	$X_n \leq 350$ mm:	± 0.3 mm
Mass	$X_n > 350$ mm:	± 0.08 % of x_n

The fixing holes are manufactured before the hardening process, which is why the length tolerances and spacings differ from the usual standards. The deviations can be offset using undercut fastening screws of type GD or GDN (see chapter 5) and/or by choosing a suitable hole (see chapter 7.10).

9.4 Operating temperatures

SCHNEEBERGER linear guideways can be used at operating temperatures from -40° C to $+80^\circ$ C. For brief periods temperatures up to $+120^\circ$ C are possible.

9.5 Speeds and accelerations

The following limit values apply for the standard designs:

Product	Max. speed	Max. acceleration
Linear guideways R, RD, RN, RNG, N/O and M/V	1 m/s	50 m/s ²
Linear guideways RN and RNG with Cage control FORMULA-S	1 m/s	300 m/s ²
Linear guideways N/O and M/V with cage control	1 m/s	200 m/s ²

9.6 Friction, running accuracy and smoothness

When manufacturing the linear guideways, SCHNEEBERGER places great value on a high level of smoothness. Transitions, run-ins and run-outs or the quality of the synthetic materials and synthetic composite cages are given top priority. This also applies in respect of the rolling elements used, which must satisfy the most stringent quality demands.

For guideways with cages under normal operating conditions a friction factor of 0.0005 to 0.0030 can be assumed.

10 Recirculating unit standard parameters

10.1 Operating temperatures

SCHNEEBERGER recirculating units can be used at operating temperatures from -40°C to $+80^{\circ}\text{C}$ (for brief periods temperatures up to $+120^{\circ}\text{C}$ are possible). For type SKC the temperature range is -150°C to $+200^{\circ}\text{C}$.

10.2 Speeds and accelerations

The following limit values apply for the standard designs:

Product	max. speed	max. acceleration
SK, SKD, SKC and SR	2 m/s	50 m/s ²
NRT	1 m/s	50 m/s ²

10.3 Friction, running accuracy and smoothness

When manufacturing the recirculating units, SCHNEEBERGER places great value on a high level of smoothness. Transitions, run-ins and run-outs or the quality of the synthetic materials are given top priority. This also applies in respect of the rolling elements used, which must satisfy the most stringent quality demands.

For recirculating units under normal operating conditions a friction factor of 0.005 can be assumed.

The versatile areas of application assume different characteristics from linear guideways and recirculating units. Various parameters and considerations essential for product selection. These are set out in detail below.

11.1 Linear guideways

Relationship between stroke H and length of the guideway L

If the stroke is below 400 mm, the following formula applies:

$$\frac{H}{L} \leq 0.7$$

If the stroke is above 400 mm, the following formula applies:

$$\frac{H}{L} \leq 1$$

L = Length of the linear guideway in mm
H = Stroke in mm

Calculating the cage length K

$$K \leq L - \frac{H}{2}$$

K = Cage length in mm
L = Length of the linear guideway in mm
H = Stroke in mm

The stroke must be limited by means of stops on the table and not by the cages. The stops should preferably be fitted along the axis of symmetry of the guideways to avoid additional forces acting on the linear guideways.

Calculating the number of rolling elements (R_A) per cage

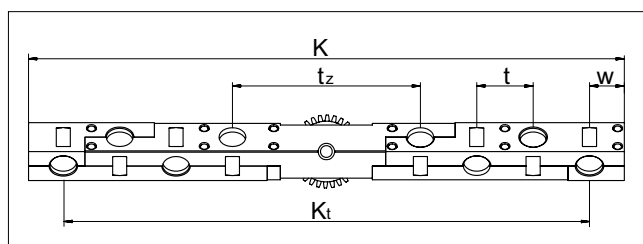

a) For cage types KBN, AC, AK, EE, SHW, HW

$$R_A = \frac{K - 2w}{t} + 1$$

or

$$R_A = \frac{K_t}{t} + 1$$

b) For cage type KBS

$$R_A = \frac{K - (2w + t_z)}{t} + 2$$

K = Cage length in mm
R_A = Total available rolling element per cage
w = Distance from cage start to the middle of the first rolling element in mm
t = cage division in mm
K_t = Load-bearing length in mm
t_z = Length of the middle section for the KBS cage

The relationship between the cage length K and the average guideway spacing Q

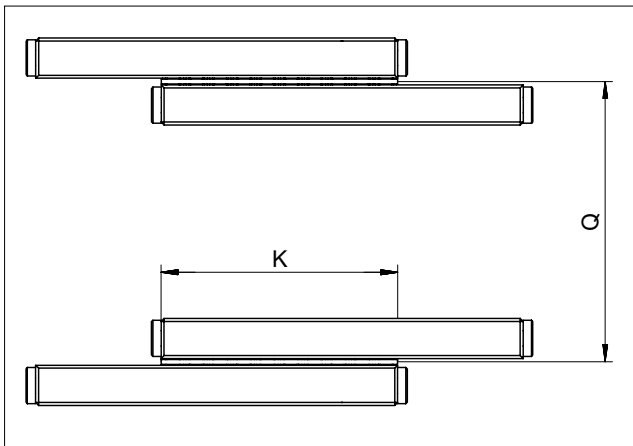

$$\frac{K}{Q} \geq 1$$

K = Cage length in mm
Q = Average linear guideway spacing in mm

The maximum permissible installation ratio in the case of overrunning cages

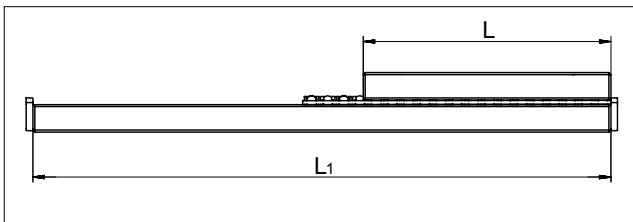

Overrunning cages are expedient if a short table is to be moved on a long guideway track. In each case the short rail for the guideway must have a rounded run-in (special version EG, see chapter 7.3) so that the overrunning cage causes as little pulsation as possible.

Not every cage is suitable for this application. The maximum cage overrun depends on the position of the rails and on the cage material.

Maximum permitted installation ratios L to L₁:

- for fixed guideways 1 : 2
- for laid on guideways 1 : 4

Installation variants for linear guideways with wipers

For different linear guideways wipers can be used in the form of end pieces (a_n). Two installation variants are possible for this. In both instances this results in the following length ratios:

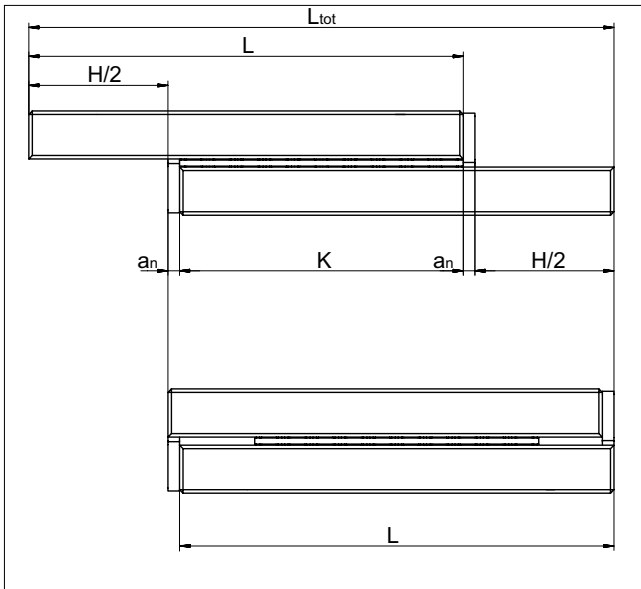

Variant 1

Roller guideways with end pieces/wipers and rails **equal** in length:

$$K = L - H/2 - a_n$$

$$L_{tot} = L + H/2 + a_n$$

With this design the linear guideways must be fitted offset by the amount a_n .

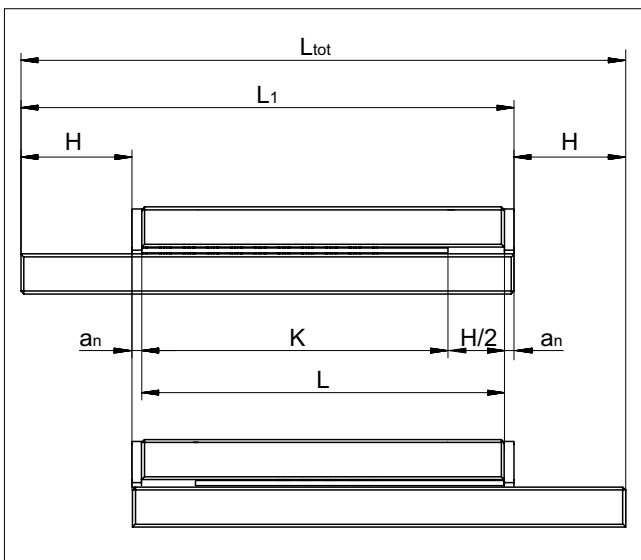

Variant 2

Roller guideways with end pieces/wipers and rails **not equal** in length:

$$K = L - H/2$$

$$L_{tot} = L_1 + H \quad (\text{if the long guideway moves})$$

$$L_{tot} = L_1 \quad (\text{if the short guideway moves})$$

K = Cage length in mm
 H = Stroke in mm
 L = Length in mm
 L_1 = Length in mm
 L_{tot} = Total length in mm
 a_n = Thickness of the end piece in mm

11 Design

11.2 Recirculating units

When using recirculating units, theoretically there is not restriction in stroke. The stroke is only restricted by the length of the guide rails.

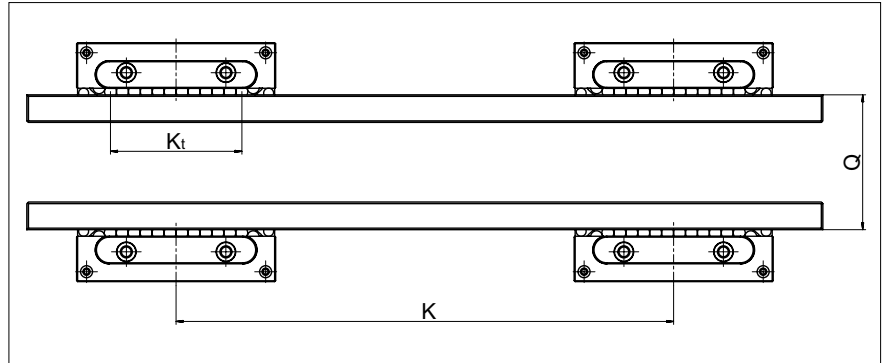

In terms of the spacing K between the recirculating units and the rail spacing Q , the following ratios are recommended as a guideline:

When using **one** recirculating unit per rail: $\frac{K_t}{Q} \geq 1$

When using **more than one** recirculating unit per rail: $\frac{K}{Q} \geq 1$

K = Spacing between the recirculating units in mm
 K_t = Load-bearing length in mm
 Q = Average rail spacing in mm

12 Load carrying capacity and service life

12.1 Basic principles

The load capacities are based on DIN ISO standard 14728 for roller-contact bearings.

In accordance with DIN, in most applications a permanent overall deformation of 0.0001 times the rolling element diameter can be permitted without adversely affecting the operating behavior of the bearing. This is referred to as the static capacity, C_0 . When designing a new application, we recommend the equivalent static load be in line with the dynamic load capacity (C) to avoid plastic deformation.

The dynamic loading capacity C is the load at which a nominal service life L of 100,000 meters of travel is achieved. It is important to note when calculating the service life that not only the load, which acts vertically on the guideway, should be taken into account but the load range of all acting forces and moments.

The service life corresponds to the travel distance in meters, which is travelled from a guideway. This is before the first sign of material fatigue occurs within the roller guideway elements. The nominal service life is achieved when 90 % of the guideways of identical construction reach or exceed the corresponding travel distances under normal operating conditions.

Critical for the dimensioning of the guideways are the loads occurring in the ratio with the dynamic loading capacity C .

Definition of service life

As previously mentioned, the dynamic loading capacity C_{100} is based on a service life of 100,000 meters. Other manufacturers frequently indicate the loading capacity C_{50} for a service life of 50,000 meters. The resulting load capacities from this are more than 20 % higher than specified in the DIN ISO standard.

Conversion examples

For balls

Convert load capacities in accordance with DIN ISO standard to C_{50} :

$$C_{50} = 1.26 \cdot C_{100}$$

Convert C_{50} load capacities in accordance with DIN ISO standard to:

$$C_{100} = 0.79 \cdot C_{50}$$

For rollers and needles

Convert load capacities in accordance with DIN ISO standard to C_{50} :

$$C_{50} = 1.23 \cdot C_{100}$$

Convert C_{50} load capacities in accordance with DIN ISO standard to:

$$C_{100} = 0.81 \cdot C_{50}$$

C_{50} = dynamic loading capacity C in N for 50,000 meters of travel distance

C_{100} = dynamic loading capacity C in N for 100,000 meters of travel distance defined in accordance with DIN ISO standard

12 Load carrying capacity and service life

12.2 Short strokes

We talk about short stroke applications when a rolling element does not travel past the position of the next rolling element during a stroke.

A continuous lubricating film forms below the rolling element

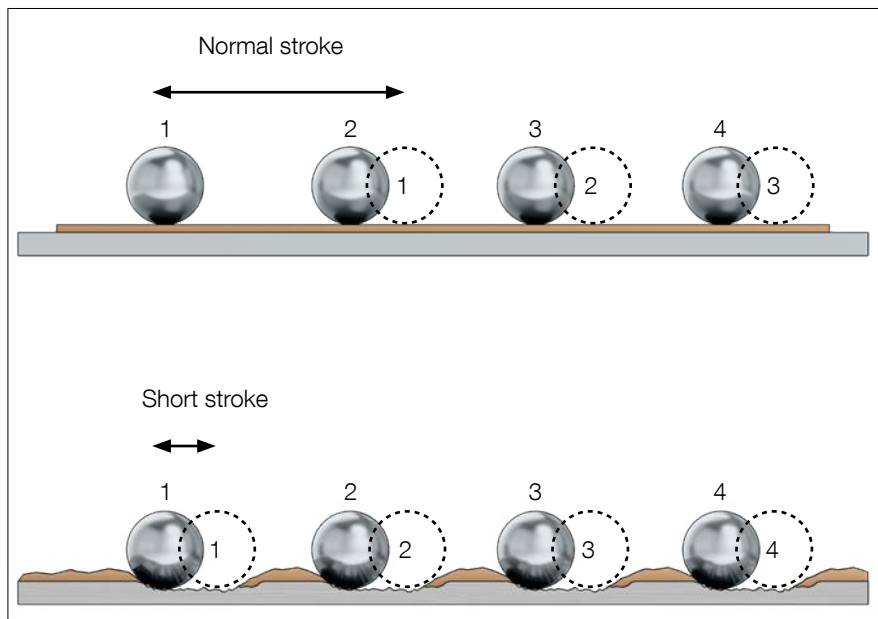

Local depressions from wear and tear form on the tracks.
At highly frequent strokes the lubricating film is also interrupted

Because the tracks are concentrated at these points (depressions from wear and tear form), the precision and service life of the guideway is reduced. When the strokes are highly frequent, a standard lubricant is no longer able to reach the points of contact.

Wear and tear can be deferred with **suitable lubricants** and regular **lubrication strokes**.

Short strokes curtail the service life of the guideway considerably. The service life of the guideway(s) can only be determined by means of testing.

12 Load carrying capacity and service life

12.3 Calculating the service life L in accordance with the DIN ISO standard

The formulas for calculating service life are:

For rollers and needles:

$$L = a \cdot \left(\frac{C_{\text{eff}}}{P} \right)^{\frac{10}{3}} \cdot 10^5 \text{ m}$$

For balls:

$$L = a \cdot \left(\frac{C_{\text{eff}}}{P} \right)^3 \cdot 10^5 \text{ m}$$

a	= Event probability factor
C_{eff}	= Effective load carrying capacity per rolling element in N
P	= Dynamic, equivalent load in N
L	= Nominal service life in m

Event probability factor a

The load carrying capacities for roller-contact bearings correspond to the DIN ISO standard. This represents a value from the service life calculation, which is exceeded with a probability of 90 % during operational use of the guideway.

If the previously mentioned theoretical service life probability factor of 90% is not adequate, the service life values will need to be adjusted by a factor a.

Event probability in %	90	95	96	97	98	99
Factor a	1	0.62	0.53	0.44	0.33	0.21

Effective load carrying capacity C_{eff}

External influences such as track hardness and temperature can reduce the loading capacity C which means that C_{eff} needs to be calculated.

$$C_{\text{eff}} = f_H \cdot f_T \cdot C$$

C_{eff}	= Effective load carrying capacity per rolling element in N
f_H	= Hardness factor
f_T	= Temperature factor
C	= Max. permissible load carrying capacity per rolling element in N

12 Load carrying capacity and service life

Hardness factor f_H

Materials in a frictionless guideway, which deviate from the standard conditions (HRC 58 - 62), can be recorded with the factor f_H :

Track hardness in HRC	20	30	40	50	55	56	57	58-62
Hardness factor f_H	0.1	0.2	0.3	0.6	0.8	0.88	0.95	1

Temperature factor f_T

Increased temperatures influence the operating conditions (material properties) and must be taken into account using the factor f_T .

Temperature of the guideway in °C	150	200	250	300
Temperature factor f_T	1	0.9	0.75	0.6

Example calculation for C_{eff}

Guideway type R6 => Hardness 58 - 62 HRC => $f_H = 1$
 Temperature 200°C => $f_T = 0.9$
 Cage AA 6 => $C = 530$ N per roller

$$C_{eff} = f_H \cdot f_T \cdot C = 1 \cdot 0.9 \cdot 530 = \underline{477 \text{ N}}$$

12 Load carrying capacity and service life

Dynamically equivalent load P

The loads (F) acting on a linear guideway system are subject to frequent fluctuations during operation. This set of circumstances should be taken into account when calculating service life. The varying load absorption of the guideway at varying operating conditions during the travel distance is described as being the dynamic equivalent load P.

Stepped load

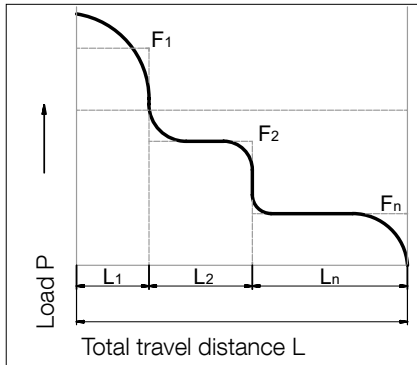

Formula for rollers and needles:

$$P = \sqrt[10]{\frac{1}{L} (F_1^{10} \cdot L_1 + F_2^{10} \cdot L_2 + \dots + F_n^{10} \cdot L_n)}$$

Formula for balls:

$$P = \sqrt[3]{\frac{1}{L} (F_1^3 \cdot L_1 + F_2^3 \cdot L_2 + \dots + F_n^3 \cdot L_n)}$$

Sinusoidal load

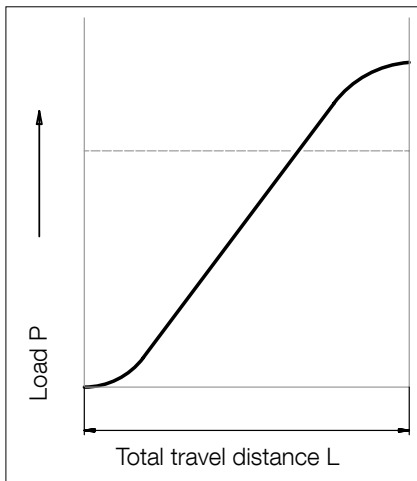

$$P = 0.7 F_{max}$$

P	= Equivalent load in N
F ₁ ... F _n	Individual load in N during the partial travel distance L ₁ ... L _n
F _{max}	Max. load in N
L	= L ₁ + ... + L _n = total travel during one load cycle in mm
L ₁ ... L _n	= partial travel distance in mm of one individual load during a load cycle

Example calculation with a linear guideway of type RNG 6-300 with KBN 6 cage

- an event probability of 97% is selected; this corresponds to a factor a of 0.44
- the dynamic loading capacity of a roller (for KBN 6 cage) is 1'800 N. If 16 rollers are used, the loading capacity of the guideway is 16 · 1'800 N = (28'800 N)
- the application generates a total load on to the guideway of 10'000 N

With the previously mentioned values, the following calculation for service life L is:

$$L = a \cdot \left(\frac{C_{eff}}{P} \right)^{\frac{10}{3}} \cdot 10^5$$

$$L = 0.44 \cdot \left(\frac{28'800 \text{ N}}{10'000 \text{ N}} \right)^{\frac{10}{3}} \cdot 10^5 = 1'495'412 \text{ m}$$

If the service life is requested in hours, the travelled stroke H (in meters) and the time t (in seconds) required for the stroke movement must be known.

The service life L_h is calculated as follows:

$$L_h = \frac{L \cdot t}{H \cdot 3'600} = \text{Service life in hours}$$

12 Load carrying capacity and service life

The correction factor R_{Tmin}

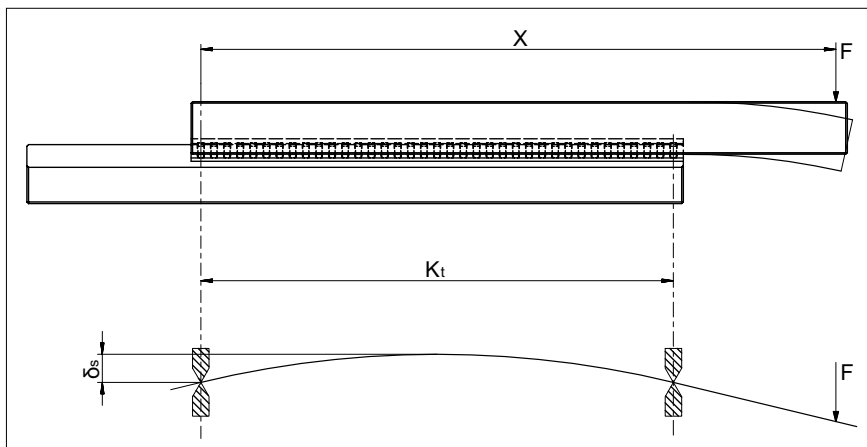

It was explained on the above pages how service life should be calculated from the given load carrying capacity and the occurring load. In doing so, the number of load bearing rolling elements per cage (R_T) should be taken into account.

Similarly important is estimating the behavior of the surrounding structure when transmitting forces to the frictionless guideway. Then an elastic deformation or a geometric error in a machine bed lead to the fact that only a part of the installed rolling element effectively absorbs load.

Reliable statements on this application-specific issue can usually only be made with a great deal of difficulty, for example by taking measurements on functioning models or using calculations based on the method of finite elements. The result of this is that normally dimensioning takes place by taking simplified measures, i.e. the external load is divided up on to few rolling elements using the correction factor R_{Tmin} .

To determine R_{Tmin} first of all the connecting structure must be assessed based on the following values from historical experience:

- A = Rigid structure
 $\delta_S \leq 0.1 \cdot \delta_A$
- B = Normal structure
 $\delta_S > \delta_A$

δ_S = deformation of the connecting structure in μm
 δ_A = deformation of the rolling element including the guide rail in μm
 (see chapter 12.5)
 F = load in N
 X = distance in mm
 K_t = load-bearing cage length in mm

12 Load carrying capacity and service life

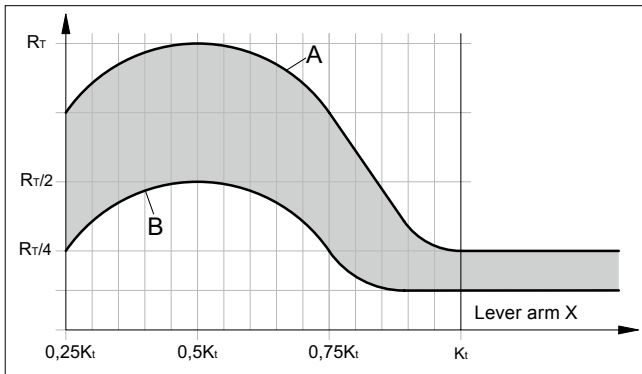

To calculate R_{Tmin} according to the diagram applies

structure	A (rigid)	B (normal)
$X > K_t$	R_{Tmin} to $R_T/4$	R_{Tmin}
$X < K_t$	as per diagram	as per diagram

For R_{Tmin} the following applies	Rolling element type	Cage types
2	Balls	AK
1	Rollers	AA, AC, EE, KBN and KBS
5	Needles	SHW and HW
0.5	Recirculating unit with rollers	SR and NRT
1	Recirculating unit with balls	SK, SKD and SKC

Example calculation No. 1

AK 6 cage

X measures 200 mm

K_t measures 90 mm

Consequently the method of calculation applies in accordance with " $X > K_t$ "

Calculation for a rigid structure:

- In accordance with the table, a ball count applies of R_{Tmin} to $R_T/4$
- R_{Tmin} corresponds to 2 balls
- $R_T/4$ corresponds to 2.25 balls

Calculation for a normal structure:

- In accordance with the table R_{Tmin} corresponds to 2 balls

Example calculation No. 2

AK 6 cage

X measures 80 mm

K_t measures 90 mm

Consequently the method of calculation applies in accordance with " $X < K_t$ "

Calculation for a rigid structure:

- In accordance with the diagram, X 0.88 from K_t is corresponding (80 mm : 90 mm) and consequently $R_T/2$
For 9 load bearing balls, this results in 4.5 balls (9 load bearing balls : 2)

Calculation for a normal structure:

The following applies in accordance with diagram R_{Tmin} , which corresponds to 2 balls in accordance with the table

12 Load carrying capacity and service life

12.4 Example calculations

The following example calculations illustrate the procedure for some typical problems.

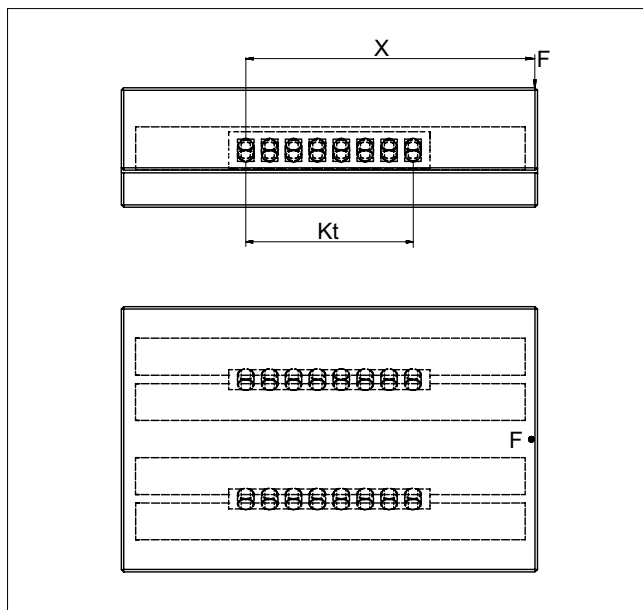

Example 1

Searched for:

Equivalent load P per roller

Assumption:

Linear guides type R 6

AC 6 cage with 8 rollers (= R_A)

$F = 350$ N

$X = 120$ mm

For the roller cage type AC 6 the following applies:

$K_t = (R_A - 1) \cdot t = (8 - 1) \cdot 9 = 63$

$R_{Tmin} = 1$ roller

$C = 530$ N

(see technical data for the AC 6 cage)

Note:

The asymmetric distribution of force is most safely taken into account when the load on the number of load bearing rolling elements (R_{Tmin}) for the guideway is reduced.

Calculation for P per roller

$$P = \frac{F \cdot x}{K_t \cdot 2} \cdot \frac{1}{R_{Tmin}}$$

$$= \frac{350 \cdot 120}{63 \cdot 2} \cdot \frac{1}{1} = 334 \text{ N}$$

P is smaller than C. The design is correct in this way.

P	= Equivalent load in N per roller
F	= load in N
C	= Max. permissible load carrying capacity per rolling element in N
X	= distance in mm
R_{Tmin}	= Correction factor
R_A	= Total available rolling element per cage
t	= cage division in mm
K_t	= Load-bearing length in mm

12 Load carrying capacity and service life

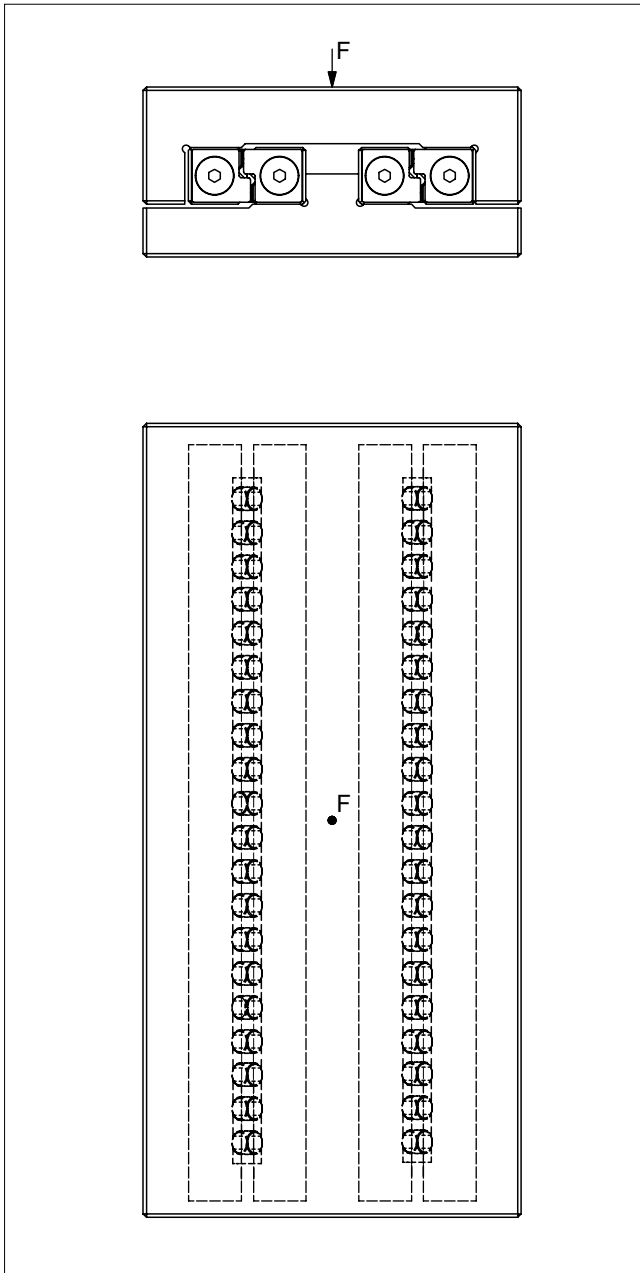

Example 2

Searched for:

Equivalent load P per roller

Assumption:

Linear guides type R 6

Roller cage type AC 6 cage with 20 rollers (= R_A)

$F = 6500 \text{ N}$

$C = 530 \text{ N}$ (according to techn. data for the AC 6 cage)

$$R_T = \frac{R_A}{2}$$

$$= \frac{20}{2} = 10 \text{ rollers}$$

Calculation for P per roller

$$P = \frac{F}{2} \cdot \frac{1}{R_T}$$

$$= \frac{6'500}{2} \cdot \frac{1}{10} = 325 \text{ N}$$

P is smaller than C. The design is correct in this way.

w = Distance from cage start to the middle of the first rolling element in mm
 t = cage division in mm
 P = Equivalent load in N per roller
 F = load in N
 C = Max. permissible load carrying capacity per rolling element in N
 R_T = Number of load-bearing rolling elements per cage

12 Load carrying capacity and service life

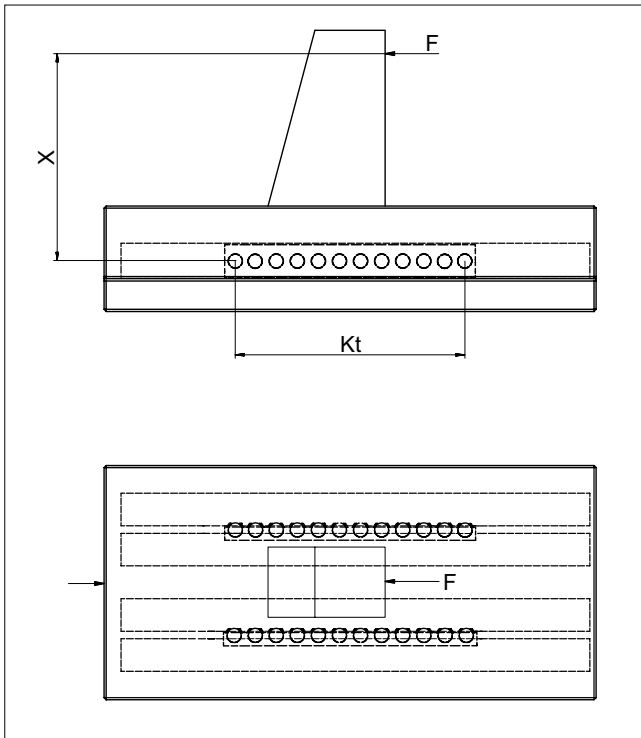

Example 3

Searched for:

Equivalent load P per ball

Assumption:

Rigid slide structure

Linear guides type R 6

Cage type AK 6 with 12 balls (= R_A); $t = 9$ mm

(according to techn. data for the AK 6 cage)

$$R_A = R_T = 12 \text{ balls}$$

$$R_{Tmin} = 3 = R_T/4 \text{ according to diagram on page 101}$$

$$K_t = (R_A - 1) \cdot t$$

$$F = 240 \text{ N}$$

$$X = 75 \text{ mm (distance F to opposing force)}$$

$$C = 65 \text{ N (according to chapter 5.1, technical data for the AK 6 cage)}$$

Calculation for P per ball:

$$P = \frac{F}{K_t} \cdot \frac{X}{2} \cdot \frac{1}{R_{Tmin}}$$

$$= \frac{240}{99} \cdot \frac{75}{2} \cdot \frac{1}{3} = 30 \text{ N}$$

P is smaller than C. The design is correct in this way.

t	= cage division in mm
P	= Equivalent load in N per ball
F	= load in N
C	= Max. permissible load carrying capacity per rolling element in N
R_{Tmin}	= Correction factor
R_A	= Total available rolling element per cage
R_T	= Number of load-bearing rolling elements per cage
K_t	= Load-bearing length in mm

12 Load carrying capacity and service life

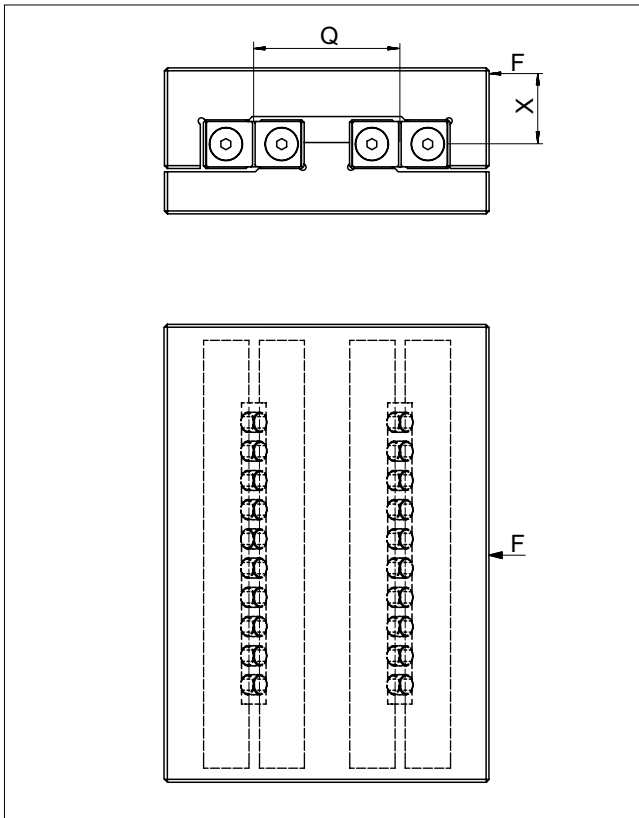

Example 4

Searched for:

Equivalent load P per roller and the suitable size RNG guideways

Assumption:

Type RNG linear guideways

Roller cage type KBN with 10 rollers (R_A)

$F = 15'000 \text{ N}$

$X = 50 \text{ mm}$

$Q = 100 \text{ mm}$

$$R_T = \frac{R_A}{2}$$

$$= \frac{10}{2} = 5 \text{ rollers}$$

Calculation for P per roller

$$P_1 = \frac{F \cdot X}{Q} \cdot \frac{1}{R_T}$$

$$= \frac{15'000 \cdot 50}{100} \cdot \frac{1}{5} = 1'500 \text{ N}$$

$$P_2 = \frac{F}{R_A}$$

$$= \frac{15'000}{10} = 1'500 \text{ N}$$

$$P = P_1 + P_2$$

$$= 1'500 + 1'500 = 3'000 \text{ N}$$

P (P_1, P_2)	= Equivalent loads in N per roller
F	= load in N
X	= distance in mm
Q	= Medium linear guideway distance in mm
C	= Max. permissible load carrying capacity per rolling element in N
R_T	= Number of load-bearing rolling elements per cage
R_A	= Total available rolling element per cage

Definition of the suitable guideway size:

According to product specification for the KBN cage (chapter 5.2 or 5.3) if $C = 3'900 \text{ N}$ were to be selected

Type	Size	Dw	t	w	C per roller in N
KBN	4	4.5	6.5	approx. 4	850
	6	6.5	8.5	approx. 5	1800
	9	9	12	approx. 7.5	3900
	12	12	15	approx. 9	6500

The roller size 9 is suitable. Thus select cage KBN 9 and the linear guideway RNG 9, provided the service life has been fulfilled.

12 Load carrying capacity and service life

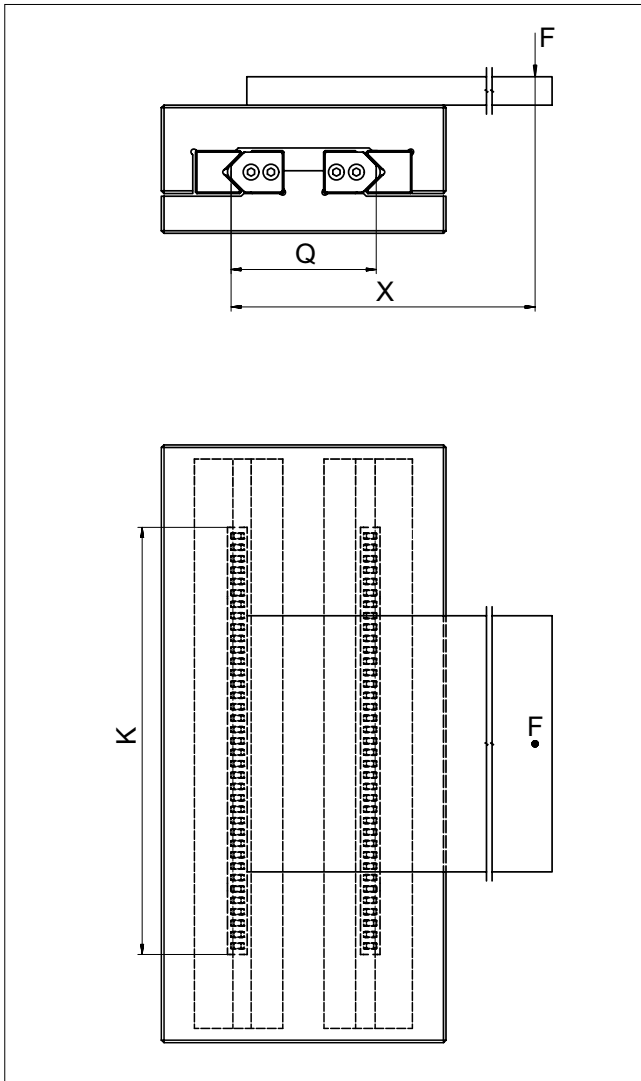

Example 5

Searched for:

Equivalent load P per needle

Assumption:

Linear guideways type N/O 2025

SHW 15 cage, cage length $K = 194$ mm

($w = 2.9$ mm according to techn. specifications of the SHW 15 cage)

$F = 5'000$ N

$X = 280$ mm

$Q = 75$ mm

$C = 750$ N (according to techn. specifications for the AC 15 cage)

$$R_A = \left(\frac{K - 2w}{t} + 1 \right) \cdot 2$$

$$= \left(\frac{194 - 5.8}{4} + 1 \right) \cdot 2 = 96 \text{ needles}$$

$$R_T = \frac{R_A}{2} = 48 \text{ needles}$$

Calculation for P per needle:

$$P = \frac{F \cdot X}{Q} \cdot \frac{1}{R_T}$$

$$= \frac{5'000 \cdot 280}{75} \cdot \frac{1}{48} = 389 \text{ N}$$

P is smaller than C. The design is correct in this way.

w	= Distance from cage start to the middle of the first rolling element in mm
t	= cage division in mm
P	= Equivalent load in N per needle
F	= load in N
X	= distance in mm
Q	= Medium linear guideway distance in mm
C	= Max. permissible load carrying capacity per rolling element in N
R_T	= Number of load-bearing rolling elements per cage
R_A	= Total available rolling element per cage
K	= Cage length in mm

12 Load carrying capacity and service life

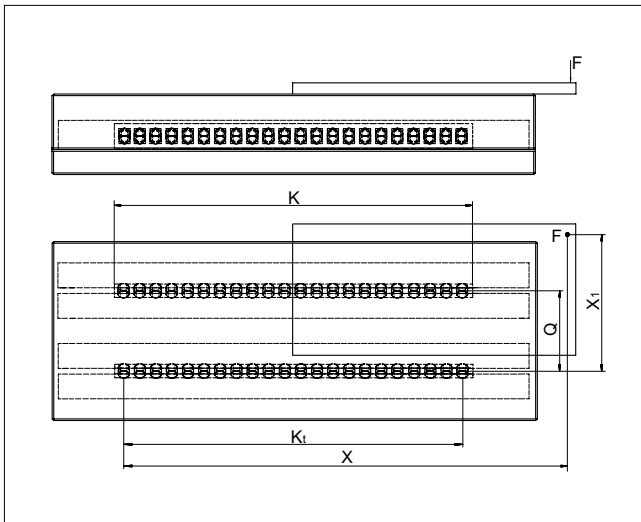

Example 6

Searched for:

Equivalent load P per roller

Assumption:

Rigid structure

Linear guides type R 12

Cage type AC 12, length K = 400 mm

F = 2'000 N

X = 500 mm

X₁ = 200 mm

Q = 100 mm

C = 2'500 N (see chapter 5.1, technical specifications for the AC 12 cage)

For the roller cage AC 12 the following applies:

$$K_t = K - 2w = 400 - 22 = 378 \text{ mm}$$

$$R_A = \frac{K_t}{t} + 1 = \frac{378}{18} + 1 = 22 \text{ rollers}$$

$$R_T = \frac{R_A}{2} = \frac{22}{2} = 11 \text{ rollers}$$

$X > K_t = R_T/4$ (according to the diagram on page 101)

$$R_{TQ} = R_T$$

$$R_{TL} = \frac{R_T}{4} = \frac{11}{4} = 2.75 \text{ rollers (rounded down to 2)}$$

Calculation for P per roller

Load laterally

$$P_Q = \frac{F \cdot X_1}{Q} \cdot \frac{1}{R_{TQ}} = \frac{2'000 \cdot 200}{100} \cdot \frac{1}{11} = 364 \text{ N}$$

Load longitudinally

$$P_L = \frac{F \cdot X}{K_t \cdot 2} \cdot \frac{1}{R_{TL}} = \frac{2'000 \cdot 500}{378 \cdot 2} \cdot \frac{1}{2} = 662 \text{ N}$$

$$P = P_Q + P_L = 364 + 662 = 1'026 \text{ N}$$

P is smaller than C. The design is correct in this way.

w	= Distance from cage start to the middle of the first rolling element in mm
t	= cage division in mm
P	= Equivalent load in N per roller
F	= load in N
X	= distance in mm
X ₁	= distance in mm
Q	= Medium linear guideway distance in mm
C	= Max. permissible load carrying capacity per rolling element in N
R _T	= Number of load-bearing rolling elements per cage
R _A	= Total available rolling element per cage
K	= Cage length in mm
K _t	= Cage length in mm
... _L	= Load-bearing length in mm
... _Q	= Longitudinally
	= Laterally

12 Load carrying capacity and service life

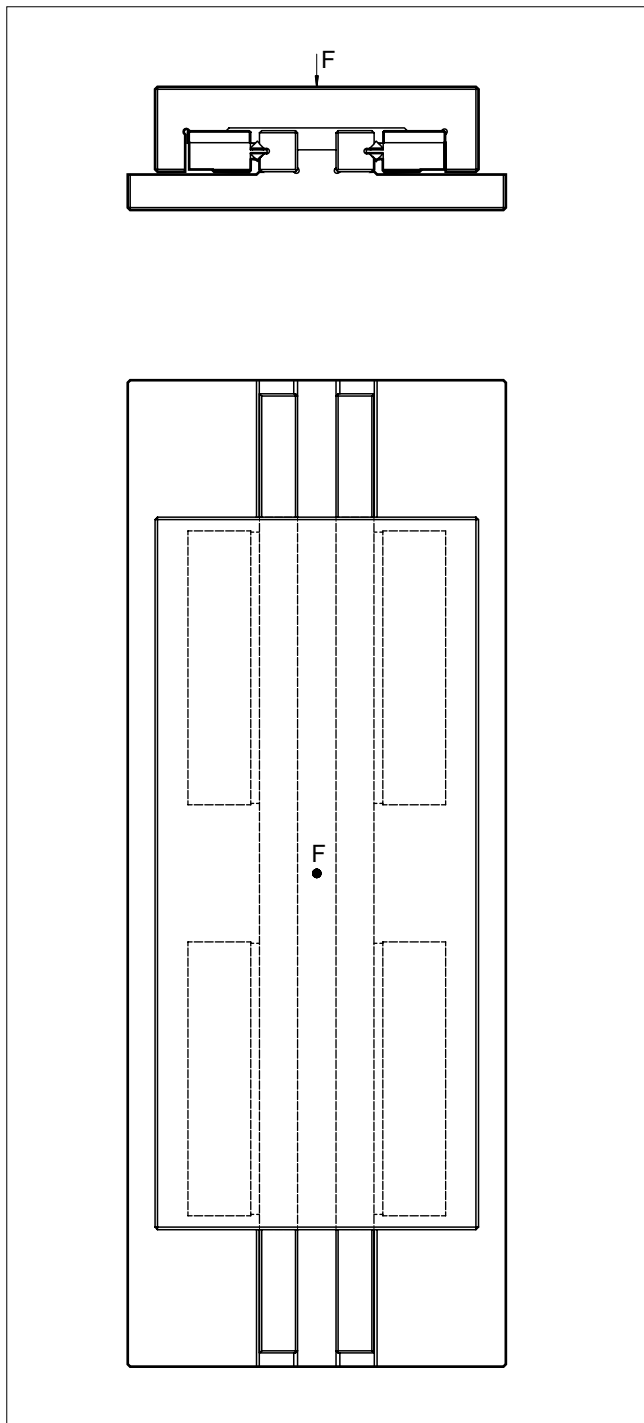

Example 7

Searched for:
Equivalent load P

Assumption:
Recirculating unit type SR 6-100
Linear guides type R 6
 $R_T = 2$ recirculating unit
 $F = 6'000$ N
 $C = 2'150$ N (see chapter 6.3, technical specifications for the recirculating unit)

Calculation for P:

$$P = \frac{F}{2} \cdot \frac{1}{R_T}$$

$$= \frac{6'000}{2} \cdot \frac{1}{2} = 1'500 \text{ N}$$

P is smaller than C. The design is correct in this way.

P = Equivalent loads in N
F = load in N
C = Max. permissible load carrying capacity in N
 R_T = Number of load-bearing recirculating units

12 Load carrying capacity and service life

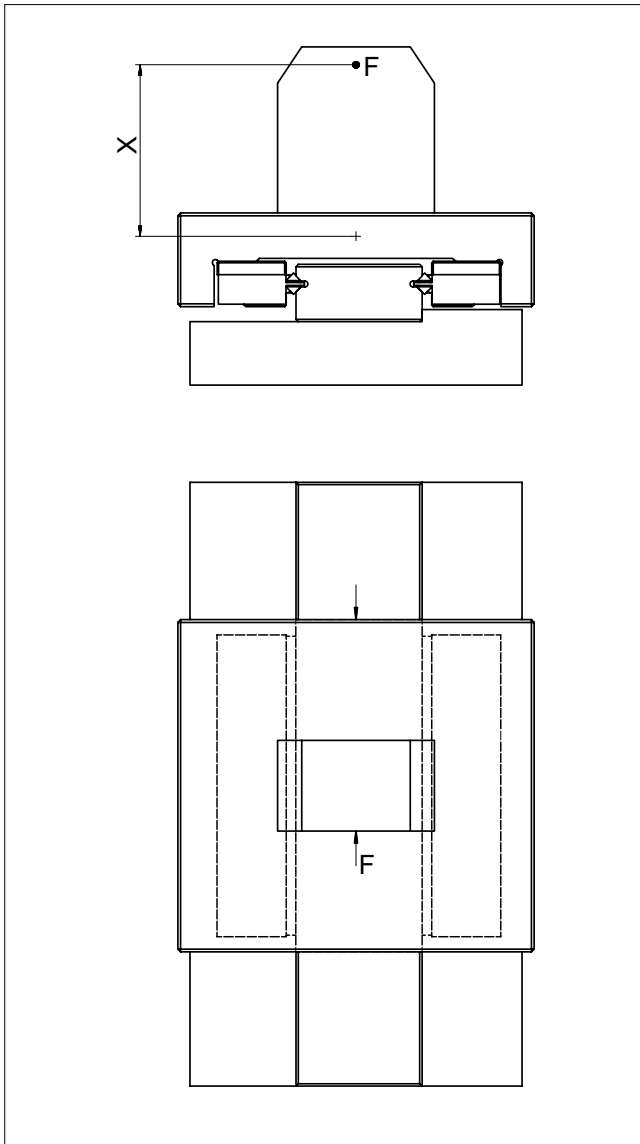

Example 8

Searched for:

Moment load M in Nm longitudinally and laterally

Assumption:

Recirculating unit type SR 6-150

Linear guideways type RD 6

$M_L = 112$ Nm (according to chapter 6.3, technical specifications

for the recirculating unit)

$X = 45$ mm (distance F to opposing force)

$F = 2'000$ N

Calculation for M :

$$M = F \cdot X = 2000 \cdot 0,045 = 90 \text{ Nm}$$

The moment load M is below the permissible load M_L . Thus the design is correct.

M = Moment load in Nm longitudinally and laterally

M_L = Permitted moment load in Nm longitudinally and laterally

X = distance in mm

F = load in N

12 Load carrying capacity and service life

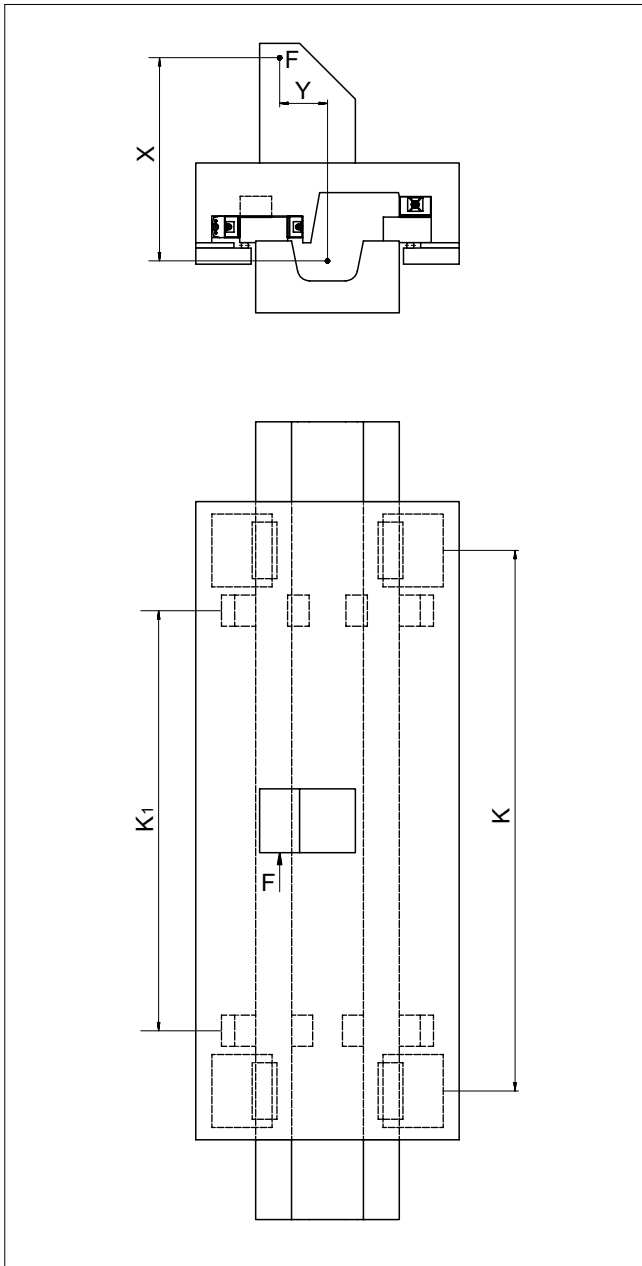

Example 9

Searched for:

Equivalent loads P_L and P_Q

Assumption:

Recirculating unit top type NRT 26 111 ($C = 98'000$ N)

Recirculating unit bottom type NRT 19 077 ($C = 43'000$ N)

Recirculating unit side type NRT 19 077 ($C = 43'000$ N)

$K = 700$ mm

$K_1 = 450$ mm

$R_{Tmin} = 0.5$ (according to table on page 101)

$F = 83'000$ N

$X = 500$ mm

$Y = 100$ mm

Calculation for P_L and P_Q :

Load longitudinally

$$P_L = \frac{F \cdot X}{K \cdot 2} \cdot \frac{1}{R_{Tmin}}$$

$$= \frac{83'000 \cdot 500}{700 \cdot 2} \cdot \frac{1}{0.5} = 59'286 \text{ N}$$

Load laterally

$$P_Q = \frac{F \cdot Y}{K_1 \cdot 2} \cdot \frac{1}{R_{Tmin}}$$

$$= \frac{83'000 \cdot 100}{450 \cdot 2} \cdot \frac{1}{0.5} = 36'889 \text{ N}$$

P	= Equivalent load in N
P_L	= Equivalent load longitudinally in N
P_Q	= Equivalent load laterally in N
F	= load in N
X	= distance in mm
Y	= distance in mm
C	= Max. permissible load carrying capacity per recirculating unit in N
R_{Tmin}	= Correction factor
K	= distance in mm
K_1	= distance in mm

12 Load carrying capacity and service life

12.5 Elastic deformation and rigidity of linear bearings

Linear guideways

The total deformation δ_A (that is the deformation of the rolling element in connection with hardened tracks (min. 58 HRC)) can be deduced from the following diagrams.

The elastic deformation of the linear guideways of type R with rollers

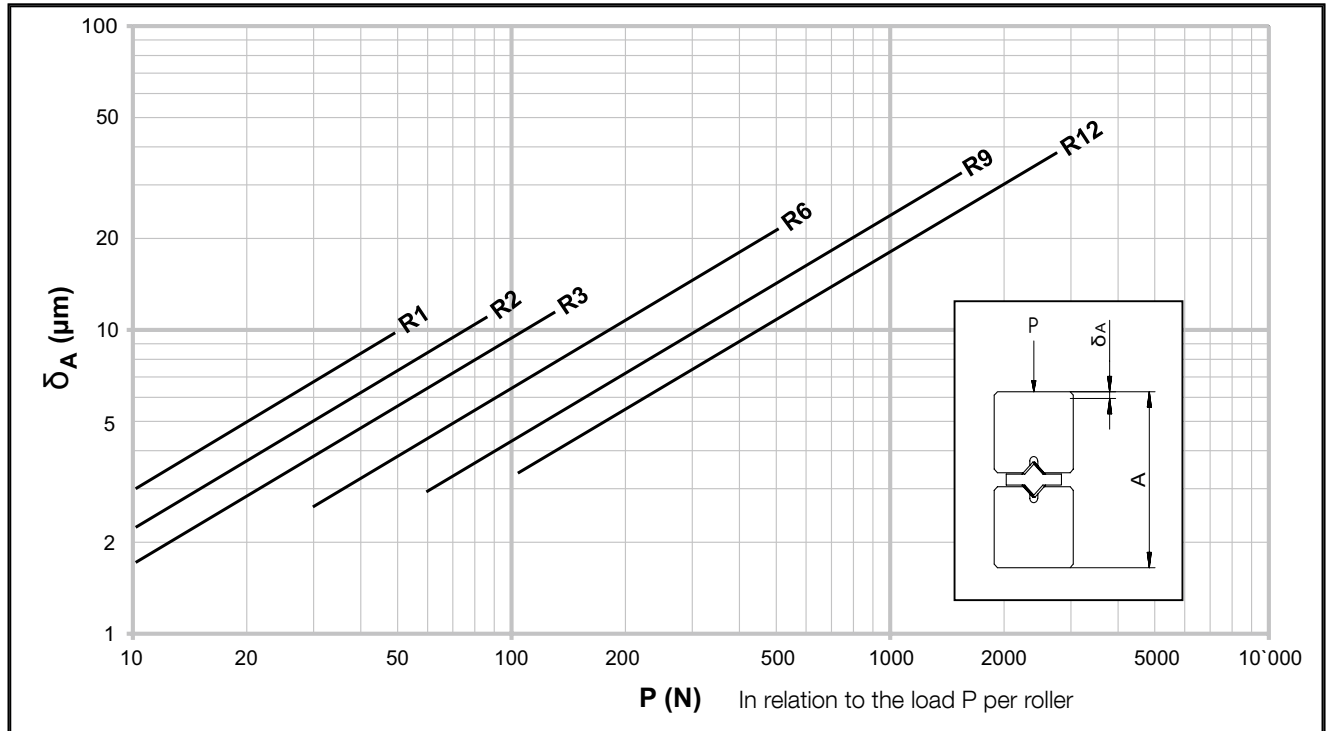

The elastic deformation of the linear guideways of type R with balls

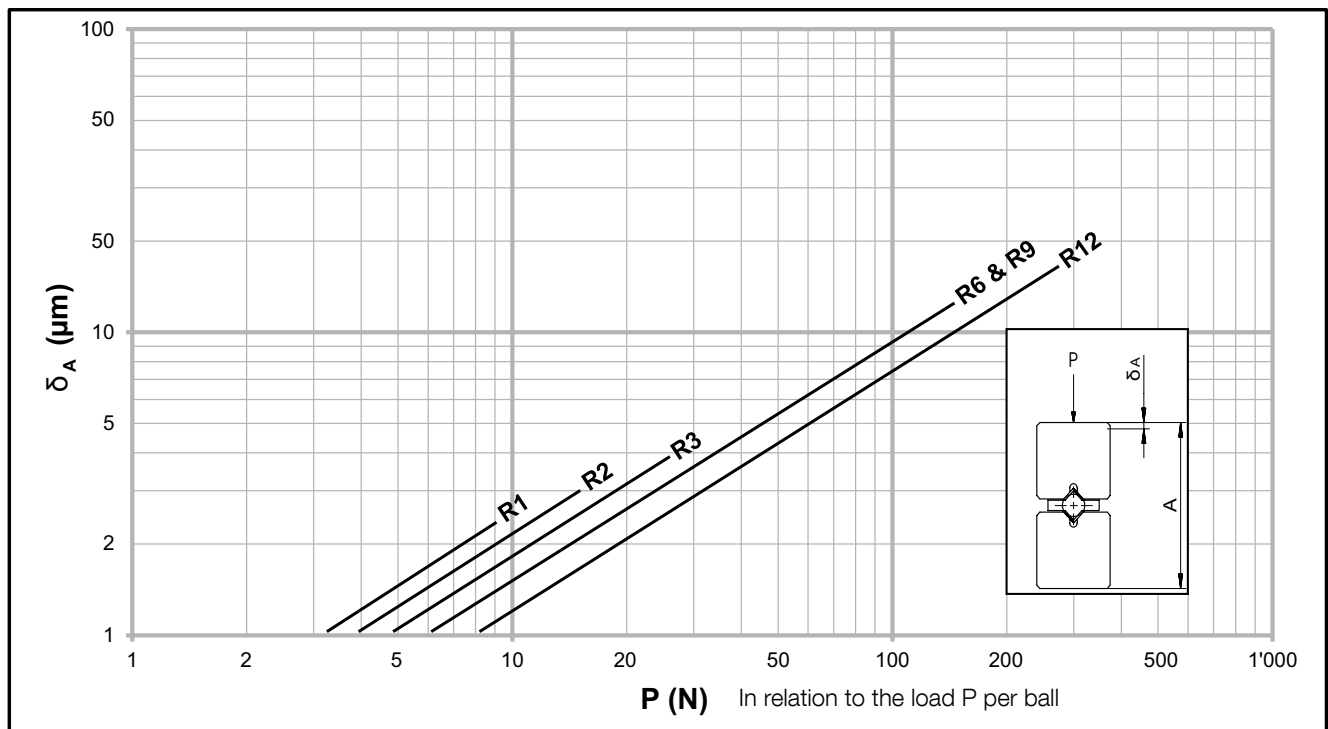

12 Load carrying capacity and service life

The elastic deformation of the linear guideways for type RN and RNG.

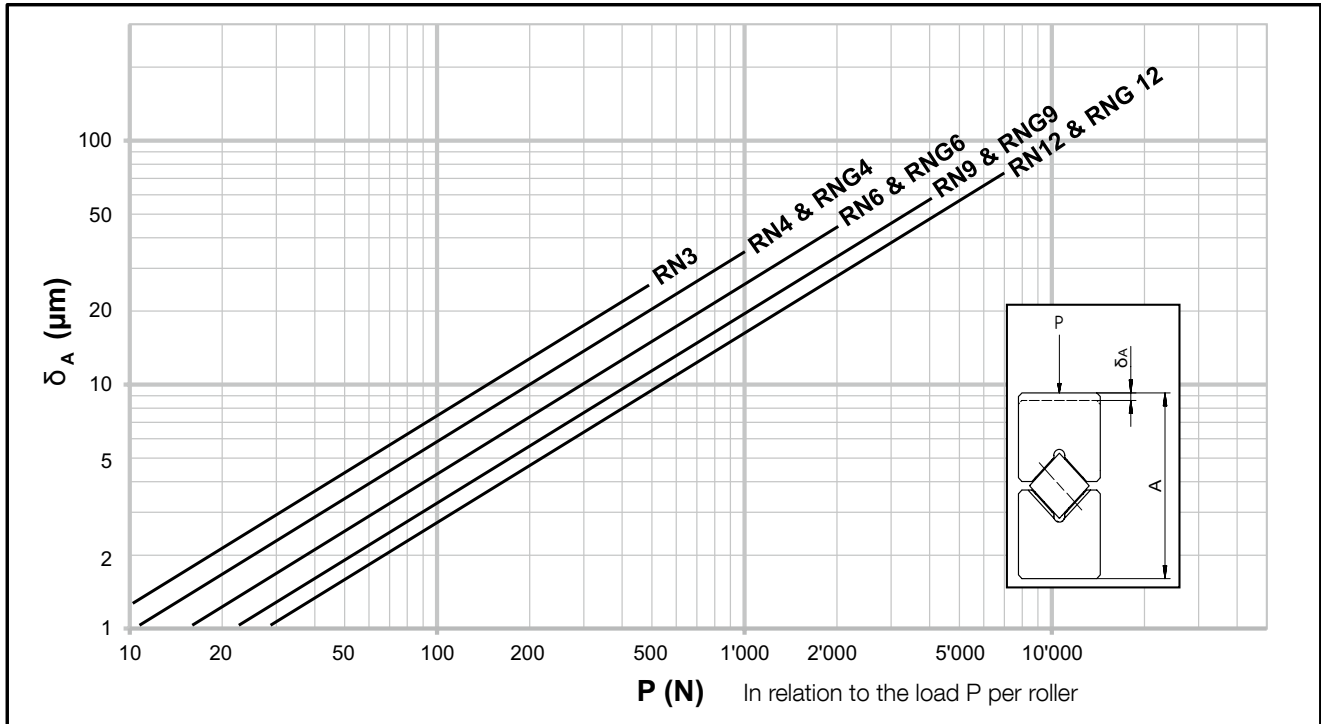

The elastic deformation of the linear guideways of types N/O and M/V upon use with the following types of cages

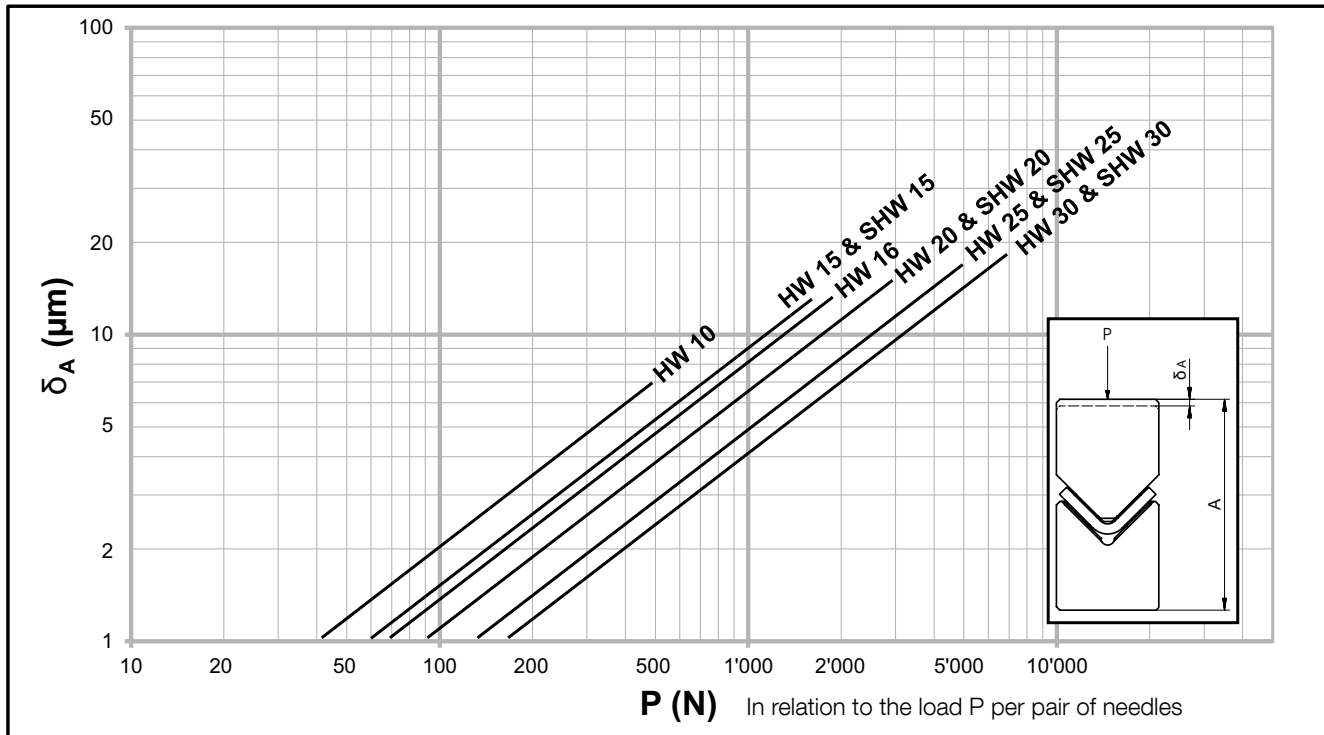

12 Load carrying capacity and service life

12.6 Elastic deformation and rigidity of recirculating units

The elastic deformation of the recirculating unit of type SK in connection with linear guideways type R or RD.

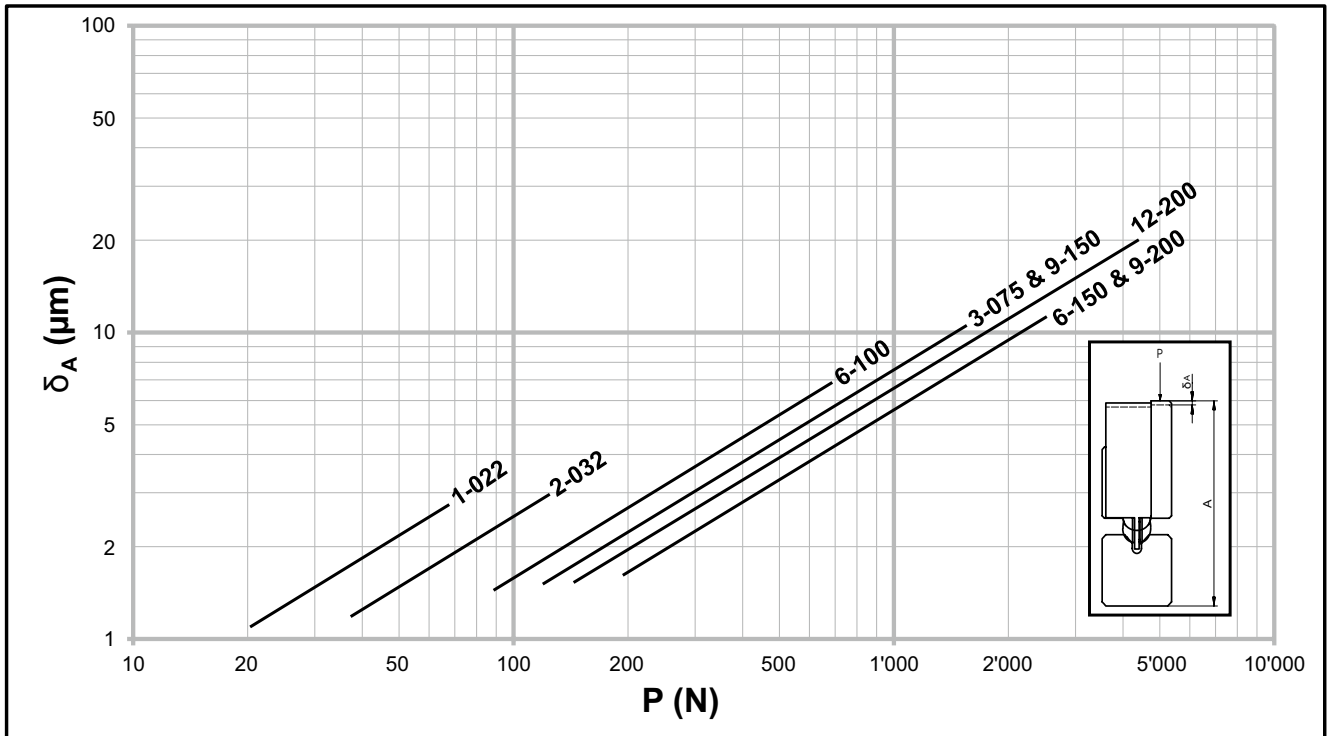

The elastic deformation of the recirculating unit of type SKD in connection with linear guideways type R or RD.

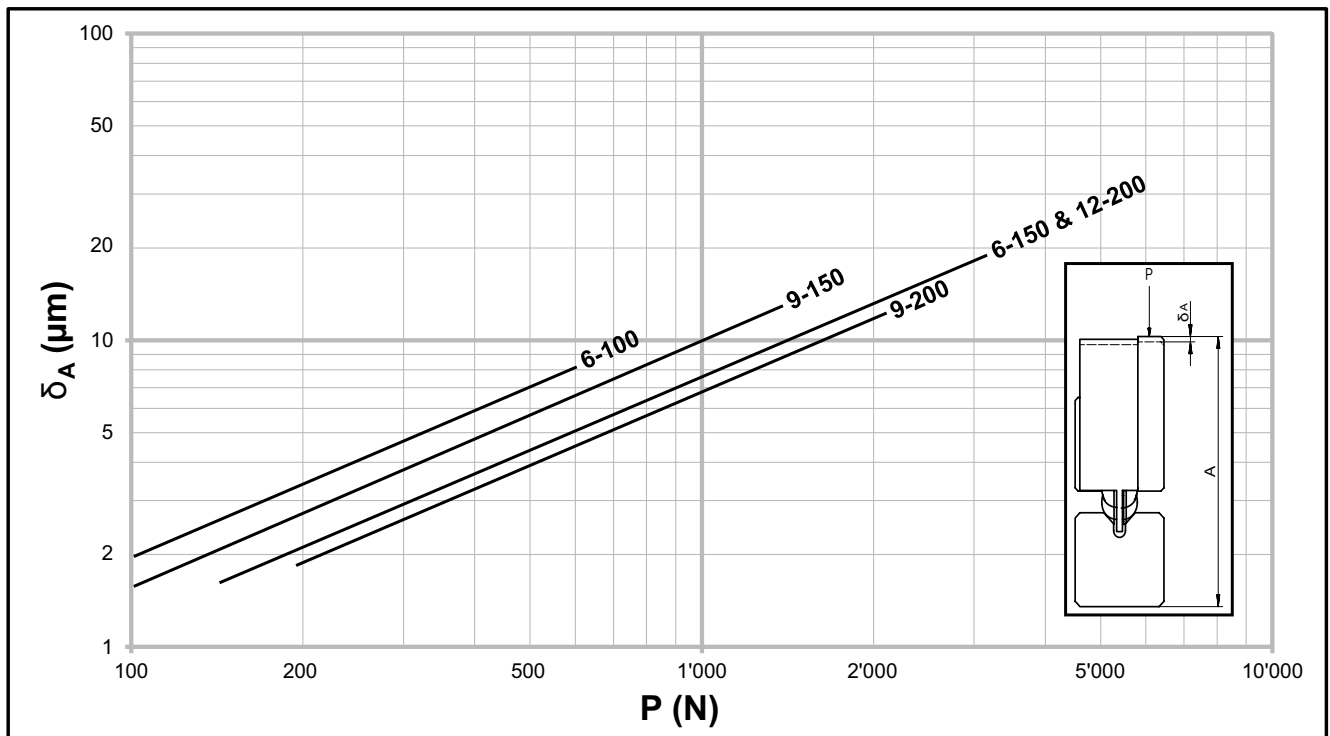

12 Load carrying capacity and service life

The elastic deformation of the recirculating unit of type SKC in connection with linear guideways type R or RD. The total length of the straight lines applies for lubricated recirculating units, the dotted straight line for unlubricated ones.

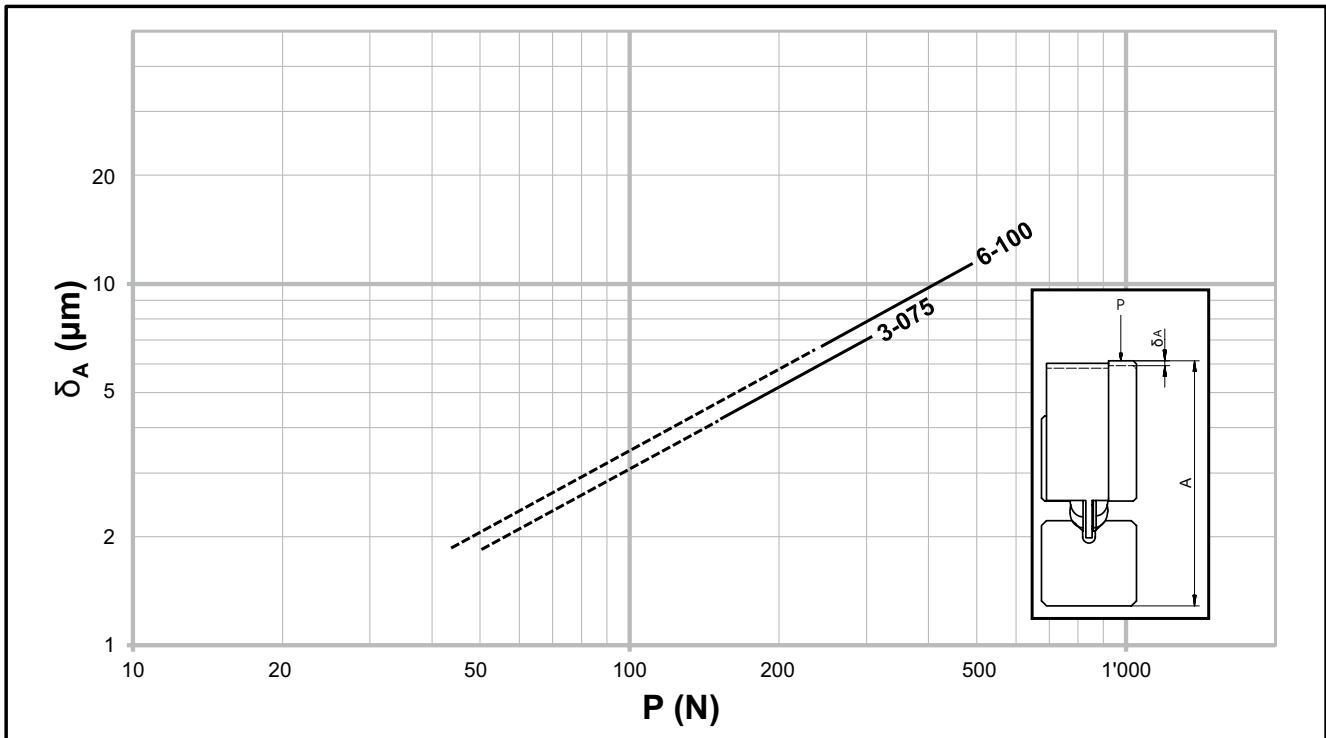

The elastic deformation of the recirculating unit of type SR in connection with linear guideways type R or RD.

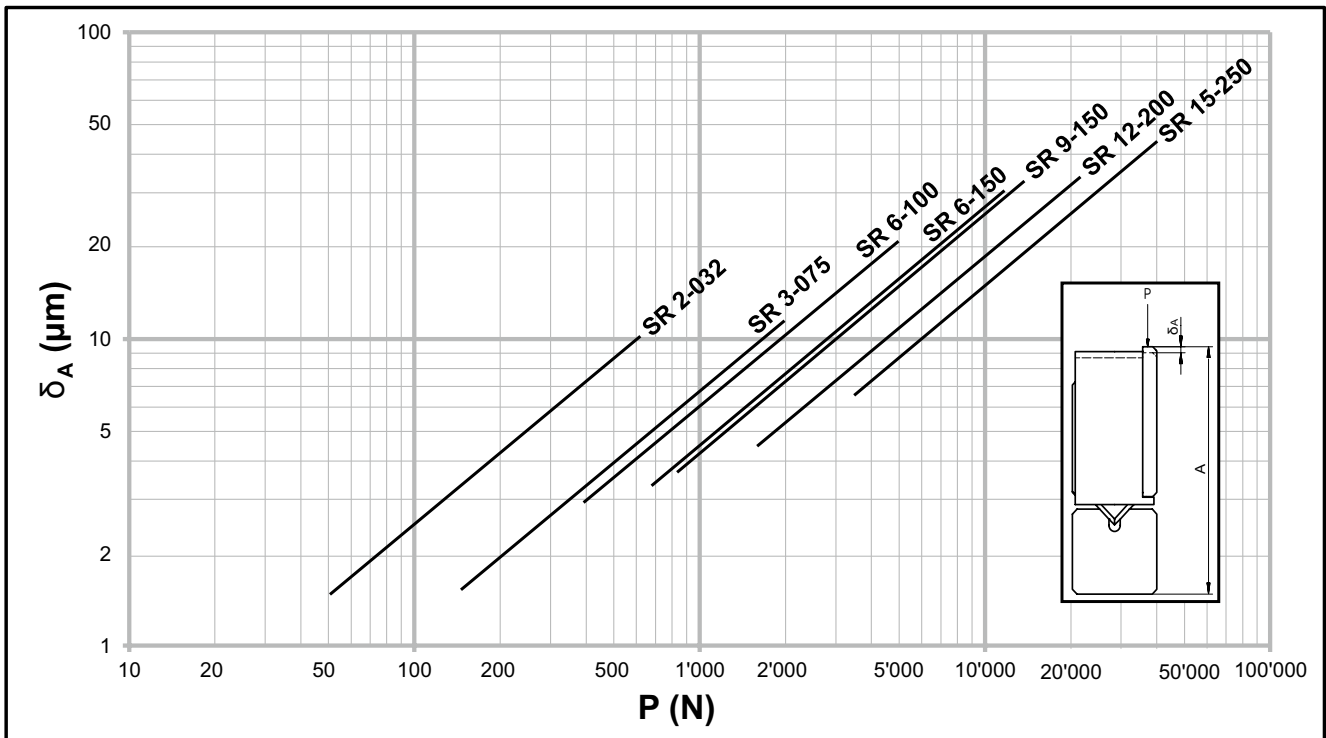

12 Load carrying capacity and service life

The elastic deformation of the recirculating unit type NRT.

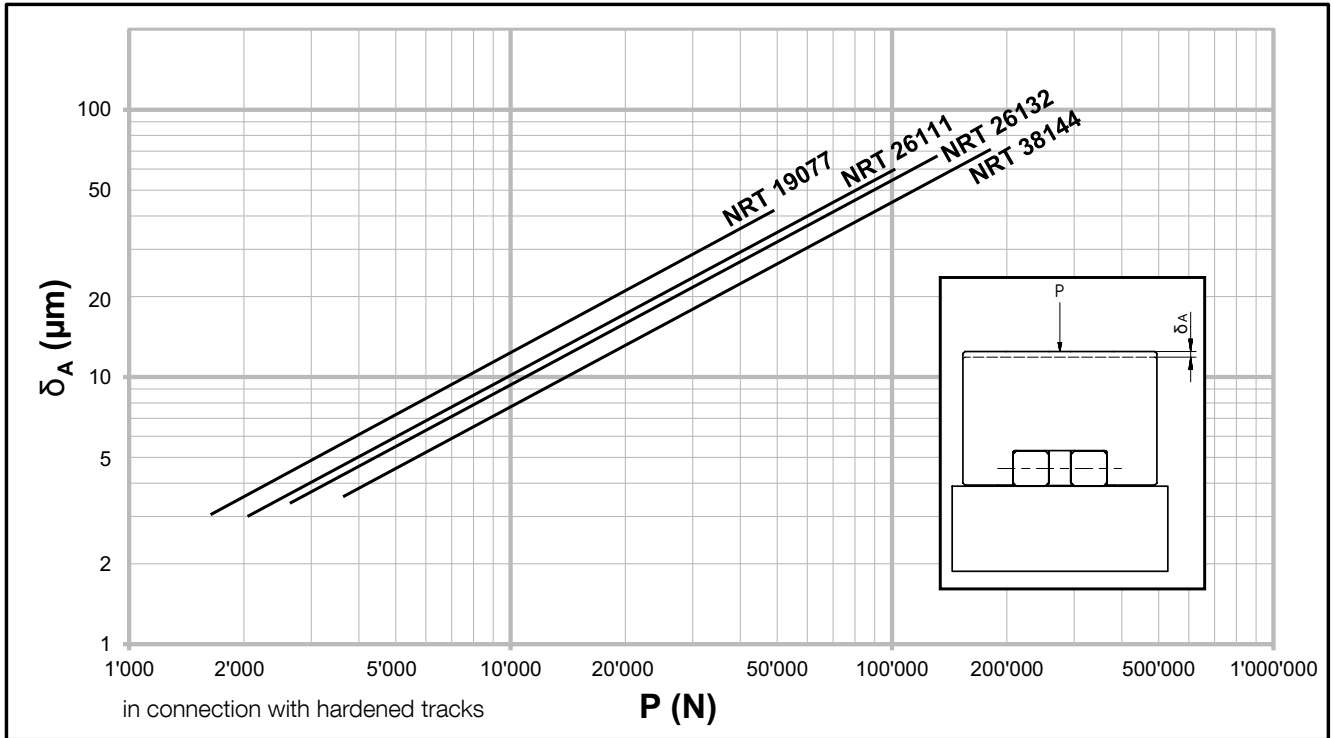

13 Construction and installation guidelines

13.1 The connecting structure and its influence on service life

Linear guideways are high-precision components. The requirements for the connecting structure are also high to ensure the accuracy of the guideways are maximized.

The quality of the reference and supporting surfaces as well as the rigidity of the connecting structure must meet the most stringent requirements. If this is not the case, smoothness, precision and service life of the guideway will be significantly affected.

To exploit the full potential of the linear guideways, assembly on a rigid and ground substrate is recommended. Connecting structures made of light metal are only suitable in certain instances - due to their lower rigidity and limited machining accuracy.

13.2 Configuration of the connecting structure

Parallelism of the reference and locating surfaces

They must be compatible with those of the linear guideway (also applies when using linear guideways with recirculating units):

- NQ Normal quality
- SQ Special quality
- SSQ Super special quality

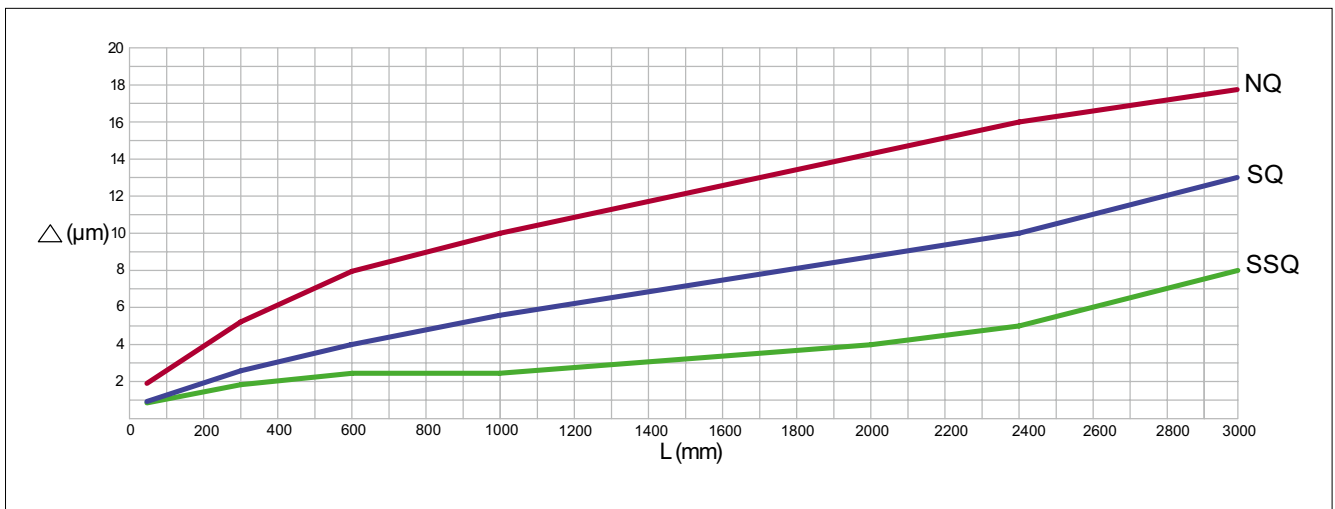

Surface quality

The accuracy of the application critically determines the required surface quality of the reference and locating surfaces. For high-precision applications they must demonstrate a maximum Ra value of 0.4. An Ra value of 1.6 may not be exceeded for standard applications.

13 Construction and installation guidelines

Angular error

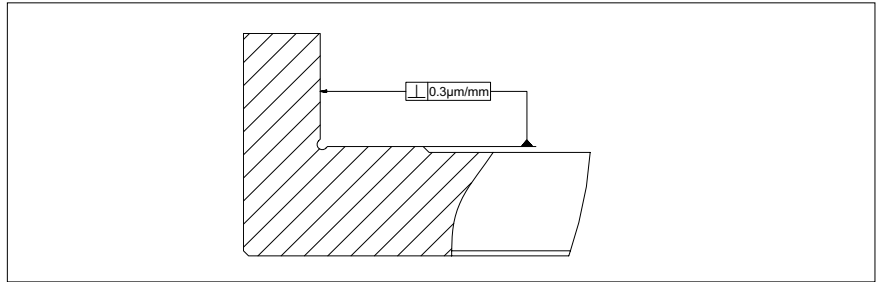

The angular errors for the supporting and locating surface should not exceed $0.3 \mu\text{m}/\text{mm}$.

Height offset for linear guideways

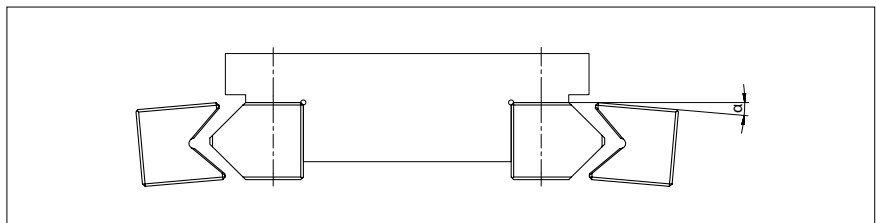

The angular errors resulting from height offset and/or elastic deformations may not exceed the following values:

Balls or rollers:	$0.3 \mu\text{m}/\text{mm}$
Needles	$0.1 \mu\text{m}/\text{mm}$

Parallelism of the supporting and locating surfaces in the case of the recirculating unit

The parallelism of the supporting and locating surfaces in relation to the mating track can be derived from the diagram below:

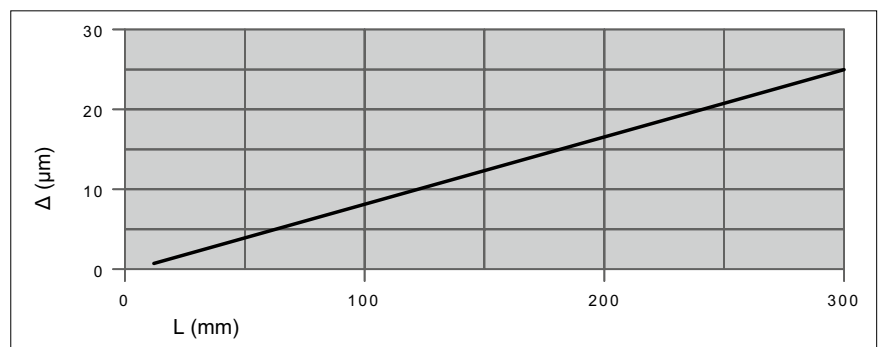

13 Construction and installation guidelines

Height offset for recirculating units

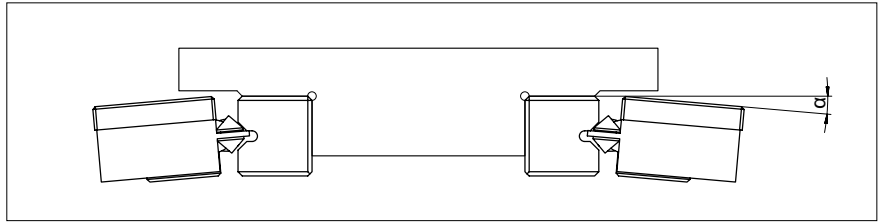

The angular errors results from height offset and/or elastic deformations may not exceed the following values:

For types SK, SKD and SKC	3.0 µm/mm
For types SR	0.3 µm/mm

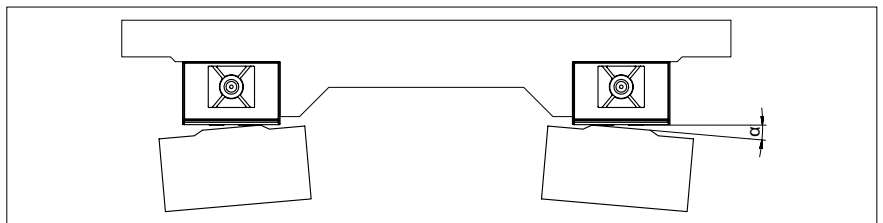

For types NRT 0.3 µm/mm

Combination of recirculating unit NRT with preload wedge NRV

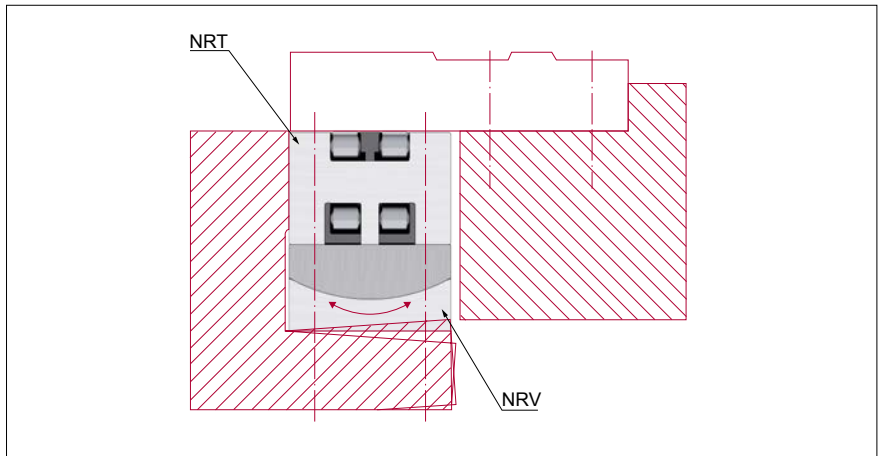

So that straight run-off is guaranteed, the recirculating unit NRT must always be oriented against the locating surface. The preload wedge NRV should be aligned opposite the recirculating unit and compensates for angular errors.

13 Construction and installation guidelines

13.3 Installation methods

SCHNEEBERGER linear guideways are not designed to be load-bearing structural components, but as guideway components.

Horizontal installation indicates direction of movement runs horizontally. Likewise, vertical installation indicates direction of movement deviates from the horizontal plane.

Enclosed configuration

The enclosed configuration is a fixed/fixed bearing. It can be loaded by moments and forces in any direction. Rigidity and running accuracy can be influenced by a change in the preload.

The advantages and characteristics of an enclosed configuration:

- Supports any operation position, load direction and moment load
- Supports a small guideway base
- Must be preloaded. Consequently, rigidity and accuracy are increased.

An example involving linear guideways of type R, RN or RNG

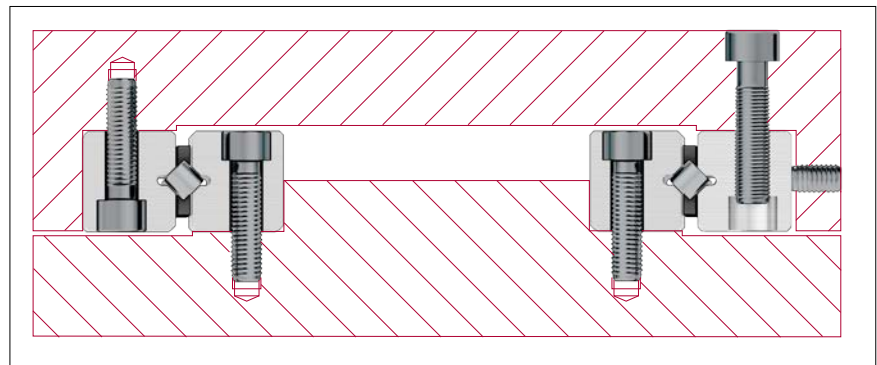

An example involving linear guideways of type N/O or M/V

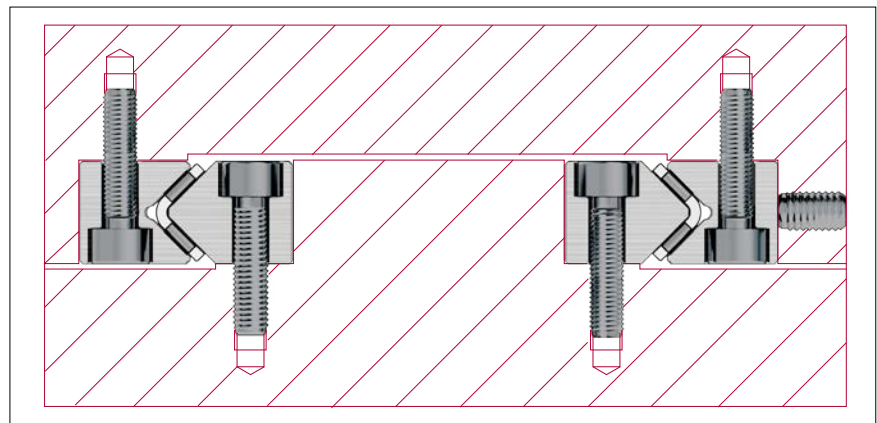

13 Construction and installation guidelines

Example with recirculating units of type SK, SKD, SKD or SR combined with the double V-shaped guide RD

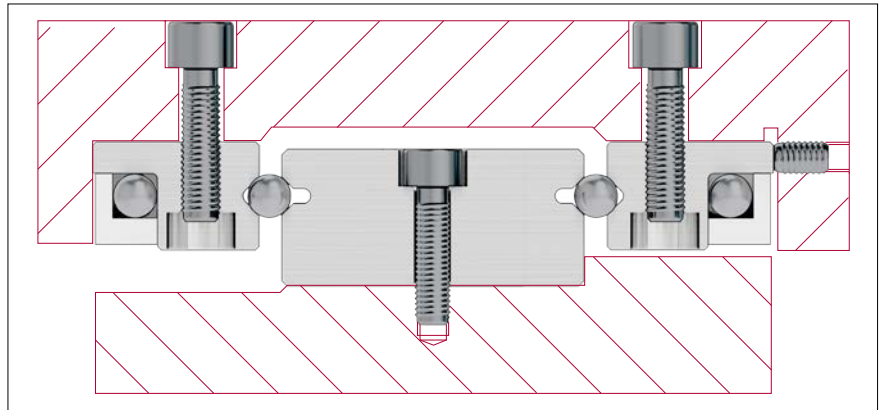

Example involving recirculating unit of type SK and linear guideways of type R

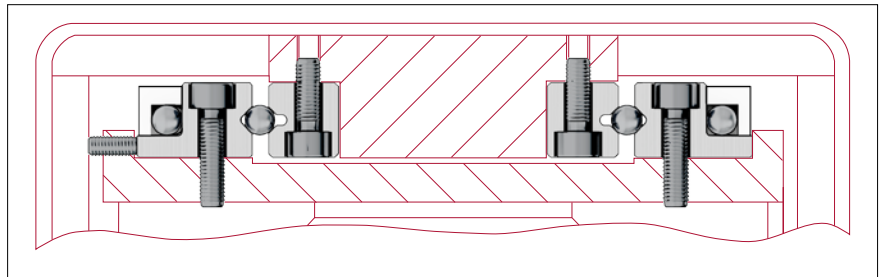

Example involving recirculating unit of type NRT and surface guideways of type E

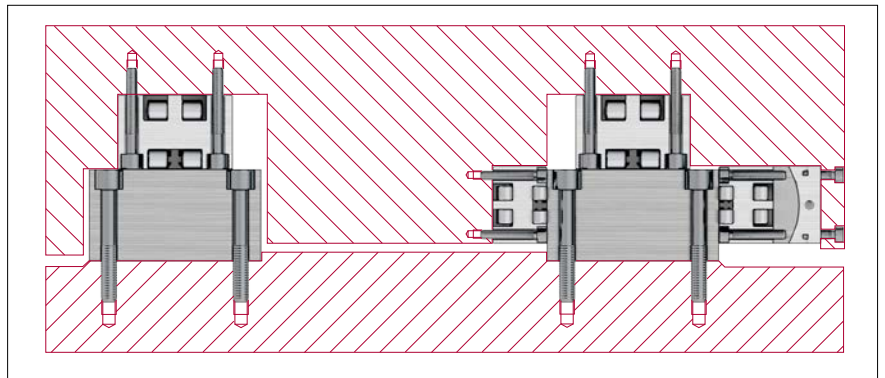

13 Construction and installation guidelines

Open configuration

The open configuration is a fixed/loose bearing offering the following advantages and characteristics:

- Is mainly used when the load acts centrally and vertically on to the guideway plane and no deformations may occur by tensioning the surrounding structure.
- Thermal lateral variations are evened out
- Large bearing spans can easily be bridged
- Requires a large guideway base
- Very installation-friendly as the machine component can easily be seated and/or lifted off

Example involving linear guideways of type R, RN or RNG combined with a surface guideway of type W/Z. In the case of open configurations, the height A for both pairs of guideways must be height-matched (see chapter 7.5).

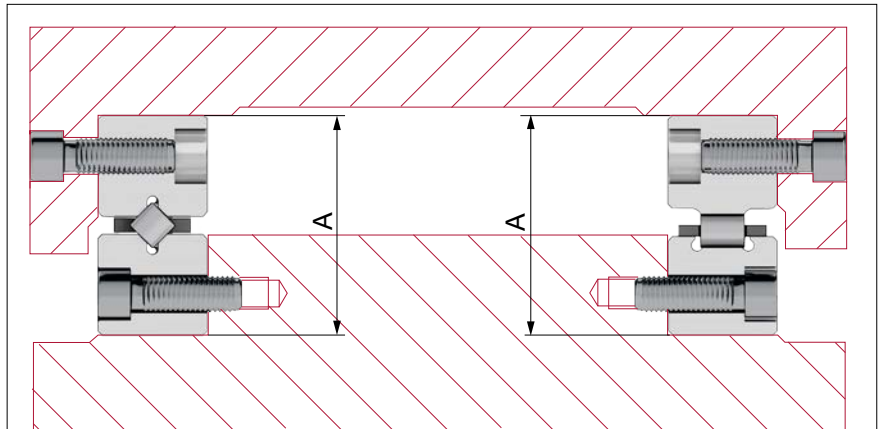

13 Construction and installation guidelines

Example of a suspended linear guideway of type N/O or M/V combined with a surface guideway of type L/M. The dimensions A and B must be height-matched.

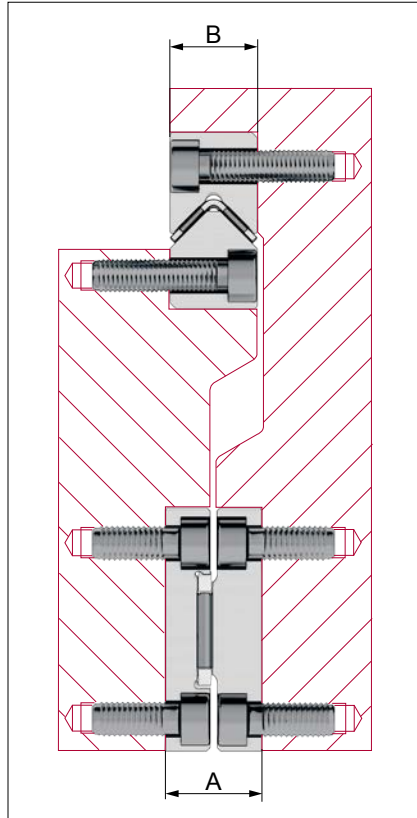

Example involving recirculating unit of type NRT and surface guideways of type E. The vertical load is born by height-matched NRT

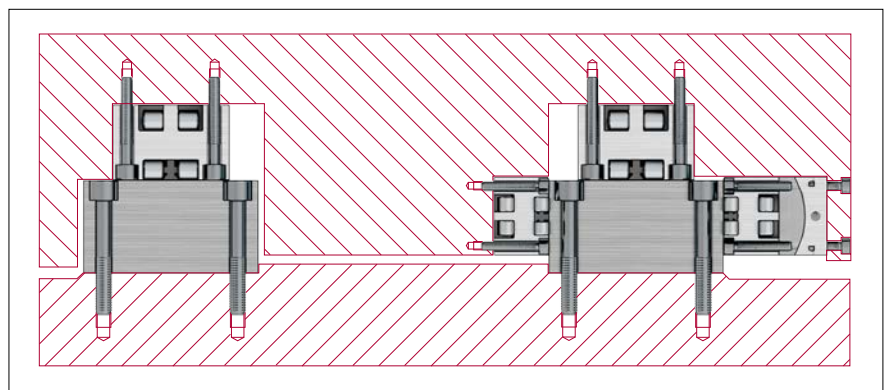

13 Construction and installation guidelines

13.4 Fastening

Linear guideways

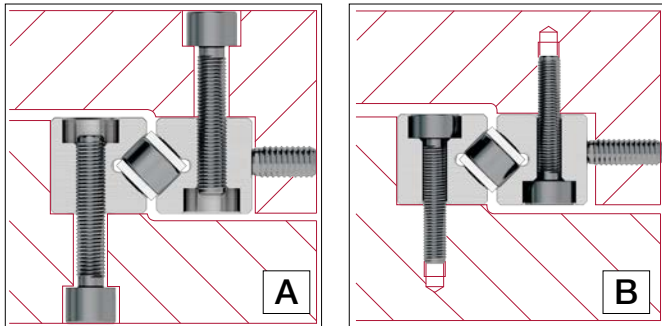

Fastening variants

The SCHNEEBERGER linear guideways and recirculating units can be fastened to the connecting structure in two different ways:

- A** The use of the tapped boreholes
- B** The use of through holes

Method A is preferred because a powerful fastening is possible based on the screw size

Method B provides added flexibility combined with the fastening screws with a thin shaft (see chapter 5).

Recirculating units

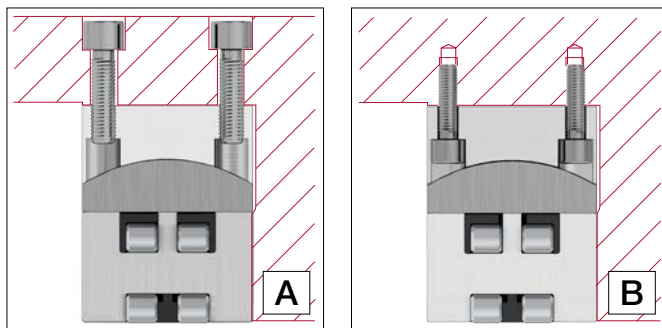
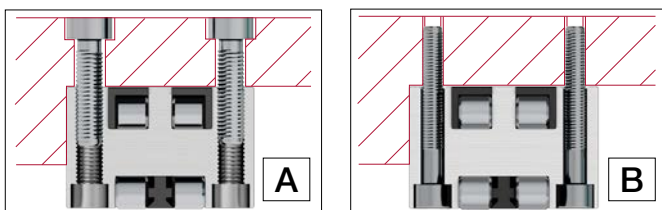
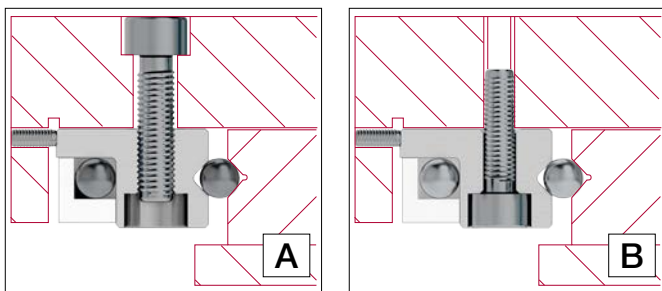

13 Construction and installation guidelines

13.5 Torque settings for fastening screws

The recommended torque settings can be found in the table. These values apply in respect of oiled screws.

By using greases containing MoS₂, the required torque can drop to half of the values set out below.

Strength grade 8.8

Sizes	Torque in Ncm	
	Fastening screws DIN 912	Fastening screws with thin shaft, type GD or GDN
M 2	35	28
M 2.5	73	58
M 3	128	102
M 4	290	232
M 5	575	460
M 6	990	792
M 8	2400	1920
M 10	4800	3840
M 12	8300	6640
M 14	13200	10560
M 16	20000	--

13 Construction and installation guidelines

13.6 Preload

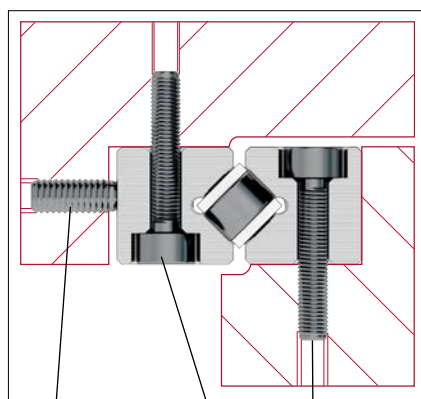

Adjusting screws

Fastening screws

The size of the preload is guided by the intended use of the guideways. A high preload ...

- ... increases rigidity of the guideway and guarantees zero-backlash
- ... reduces moment loads, maximum loads on the rolling element
- ... increases displacement resistance
- ... reduces the service life

A positive effect of preload is achieved with 5 % - 20 % of the permissible load C.

General approach

The preload can be consistently set using a torque wrench. In so doing the friction between screw and tapped fixing hole must be taken into account (to be determined by means of tests).

When using **wedge adjusters or adjusting plates**, the ideal preload must be determined based on the elastic total deformation δ_A (see chapter 12.5) and the deformation of the connecting structure.

When setting an R-guideway with **cage type EE**, the cage must first be slightly compressed before the rollers are applied.

As mentioned above, the preload increases the rigidity of the guideway. A high preload, however, requires a stable connecting structure. Otherwise unwanted edge loads occur to rollers and needles as a result of angular errors, which in turn has a negative impact on load carrying capacity.

Procedure for linear guideways

A guideway is normally set with zero-backlash using **adjusting screws**. A zero-backlash, uniform sequence is only achieved when advancing exclusively takes place where the cage with the rolling elements is located (see also chapter 13.9).

At least one **adjusting screw** must be provided per **fastening screw**, the thread size of which should match the **fastening screw**. In the case of **overrunning cages**, the shorter rail should preferably be advanced.

13 Construction and installation guidelines

Example calculation for the infeed force per adjusting screw (Pvs) of their tightening torque (Mds)

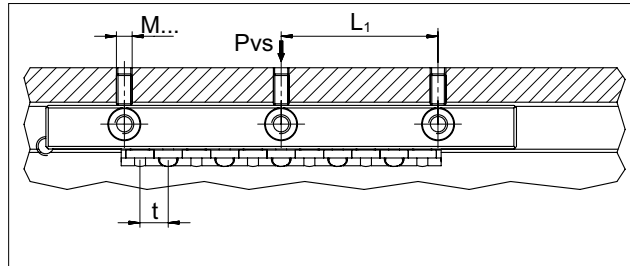

Required information per calculation:

- Linear guide type R 3 L₁ = 25 mm
- Roller cage type AC 3 t = 5 mm
- Diameter of the adjusting screw C = 130 N
= M4
- Factor f (for rollers = 1; for balls / needles = 2) f = 1
- Preload p (2 % to 20 % of C) p = 10 %
- Factor a in cm (as per the following table)

Thread	Factor a
M2	0.0238
M2.5	0.0294
M3	0.035
M4	0.0469
M5	0.058
M6	0.0699
M8	0.0926
M10	0.1152
M12	0.1378
M14	0.1591
M16	0.1811

Calculation of the infeed force per adjusting screw Pvs

$$P_{vs} = L_1 / t \cdot C \cdot p / 100 \cdot f$$

$$= 25 / 5 \cdot 130 \cdot 10 / 100 \cdot 1 = 65 \text{ N}$$

Calculation of tightening torque Mds

$$M_{ds} = P_{vs} \cdot a$$

$$= 65 \cdot 0.0469 = 3.05 \text{ Ncm}$$

13 Construction and installation guidelines

Other technical possibilities for preloading linear guideways include:

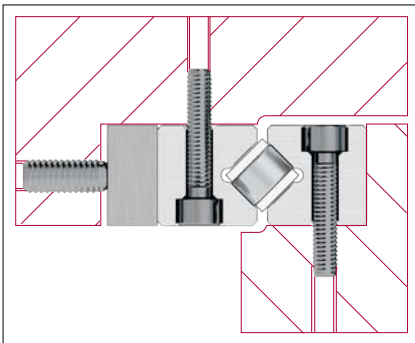

Setting using an **adjusting strip**

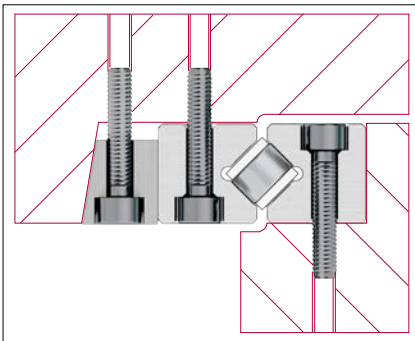

Setting using a **wedge adjuster**

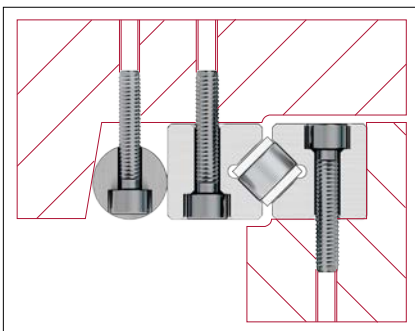

Setting using a **cylinder adjuster**

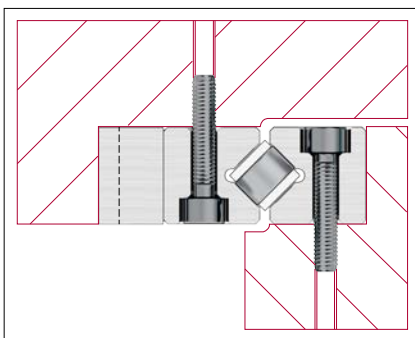

Setting using a **longitudinal wedge**

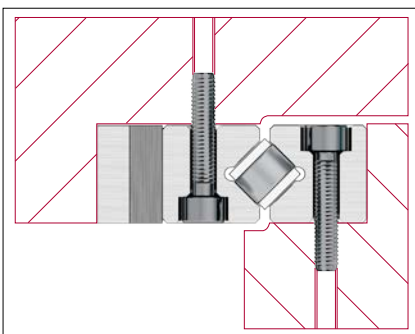

Setting using a **double longitudinal wedge**

13 Construction and installation guidelines

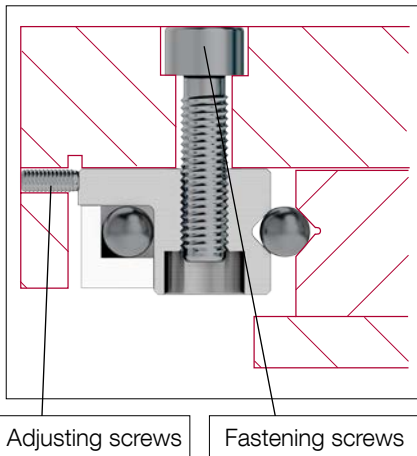

Procedure when preloading recirculating units (SK, SKD, SKC and SR)

A recirculating unit is normally set with zero-backlash using **adjusting screws**. At least one adjusting screw must be provided per **fastening screw**, the thread size of which should match the fastening screw.

Example calculation for the infeed force per adjusting screw (Pvs) of their tightening torque (Mds)

Required information per calculation:

- Recirculating unit SK 6-100 C = 715 N
- Diameter of the adjusting screw = M4
- Number of adjusting screws N = 2
- Factor f ("1" for roller, "2" for balls) = 2
- Preload p (5 % to 20 % of C) = 10%
- Factor a in cm as per the following table

Thread	Factor a
M2	0.0238
M2.5	0.0294
M3	0.035
M4	0.0469
M5	0.058
M6	0.0699
M8	0.0926
M10	0.1152
M12	0.1378
M14	0.1591
M16	0.1811

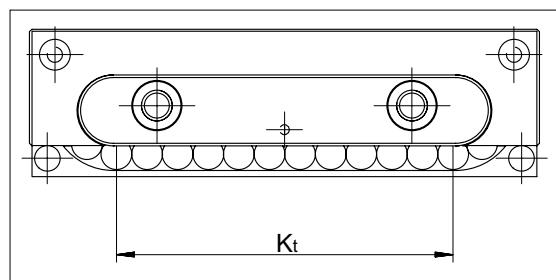

Calculation of the infeed force per adjusting screw Pvs

$$P_{vs} = C / N \cdot p / 100 \cdot f$$

$$= 715 / 2 \cdot 10 / 100 \cdot 2 = 71.5 \text{ N}$$

Calculation of tightening torque Mds

$$M_{ds} = P_{vs} \cdot a$$

$$= 71.5 \cdot 0.0469 = 3.35 \text{ Ncm}$$

Its advance must always remain within the load-bearing length K_t !

13 Construction and installation guidelines

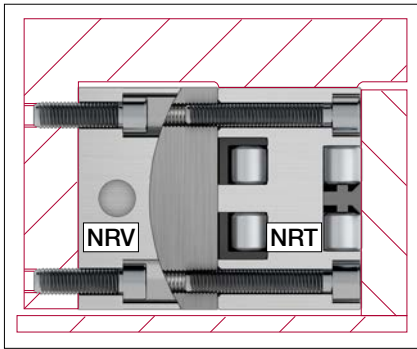

Procedure for recirculating unit NRT with preload wedge type NRV

For preload using preload wedge NRV the following infeed values apply:

Type	Size	Max adjustment range in terms of height (mm)	Height difference per revolution of the preload screw A
NRV	19077	0.35	0.0350
	26111	0.40	0.0625
	26132	0.40	0.0625
	38144	0.40	0.0750

After successfully setting the preload, always tighten the two lock nuts alternately and use the wrench applying the same amount of torque!

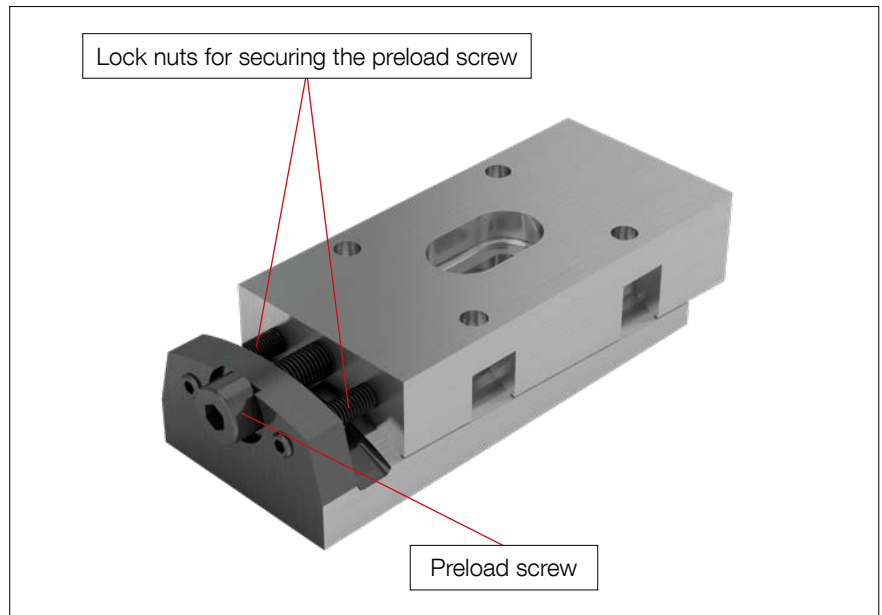

If preloading takes place without preload wedge NRV it is important to ensure that the advance must always remain within the load-bearing length K_t .

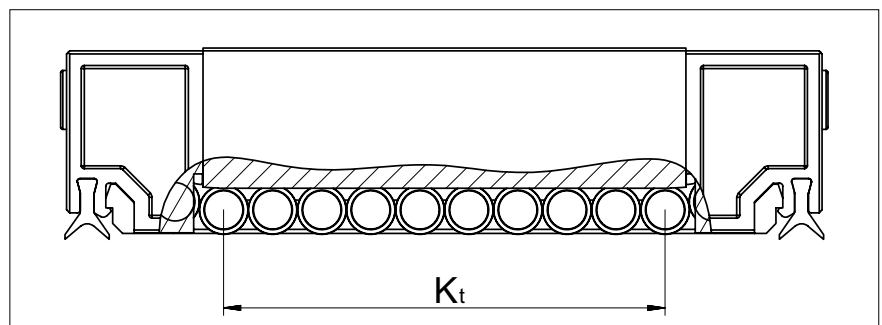

13 Construction and installation guidelines

Other technical possibilities for preloading the NRT include:

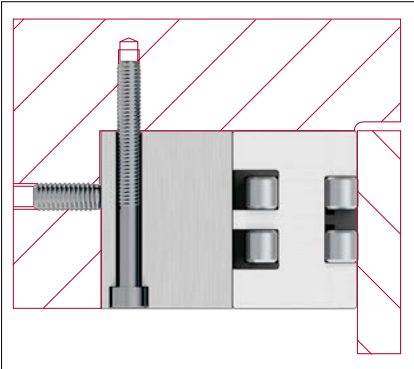

Setting using an **intermediate plate**

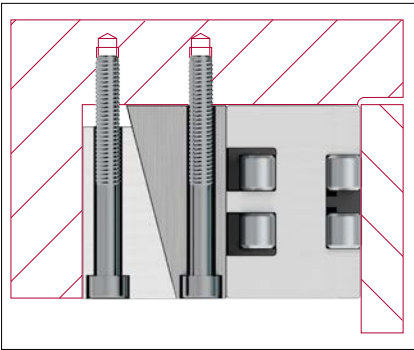

Setting using a **wedge adjuster**

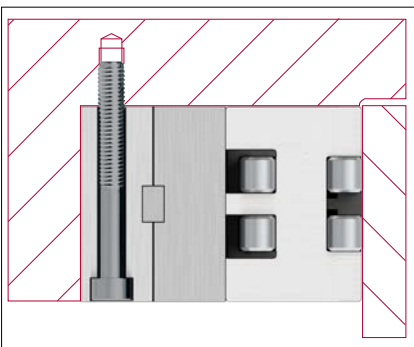

Setting using a **double longitudinal wedge**

13 Construction and installation guidelines

13.7 Sealing and covers

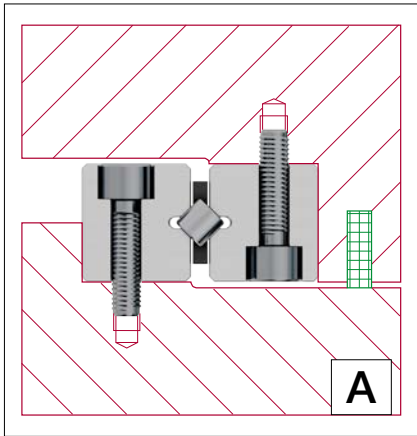

The method of sealing or covering is significant for the smooth operation and service life of the guideways.

Where there is only a small amount of dirt, wipers are sufficient to keep the tracks clean. Their braking effect can generally remain unattended. We offer a variety of standard wipers, which are described in detail in the respective product specifications.

Covers are used when there is some danger of harmful contamination of the guideway. While wipers only push the dirt off the running surfaces in the area of their movement, covers provide the opportunity of also keeping penetrating dirt away at the sides.

Some design options are listed below:

- A = Wiper sideways
- B = Diverting swarf and coolant away using a cover
- C = Labyrinth seals offer an effective and economically viable protection
- D = Simple metal cover
- E = Roll-up cover
- F = Bellows above or below
- G = Telescopic cover

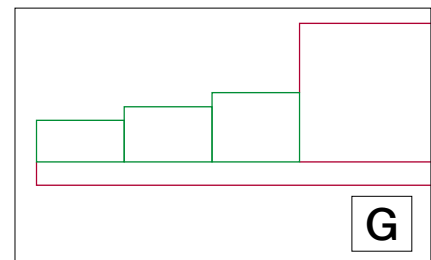
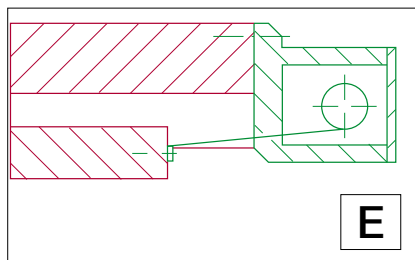
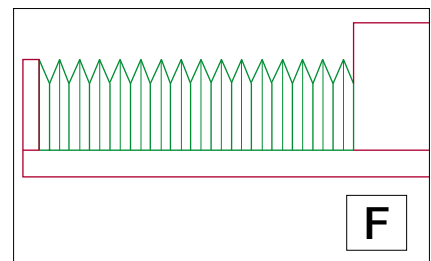
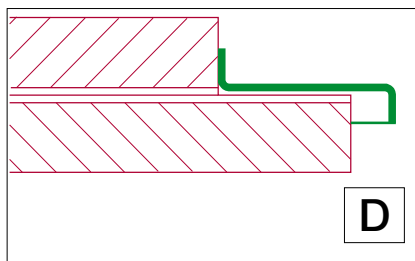
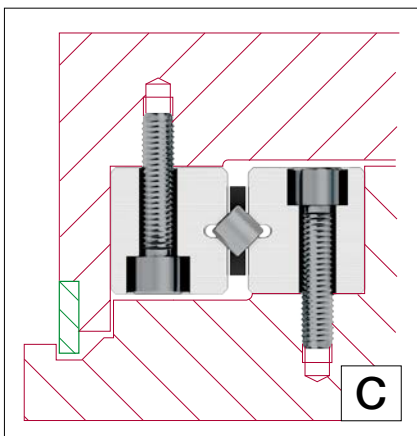
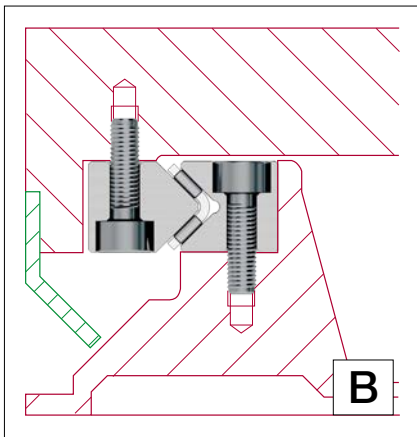

13 Construction and installation guidelines

13.8 Lubrication

Lubrication is a design element and must therefore be defined during the development phase of a machine or application. If the lubrication is only selected after design and construction is complete, based on experience this is likely to lead to considerable difficulties. A carefully thought out lubrication concept is therefore a sign of a state-of-the-art and well devised design.

Parameters to be taken into account in selecting the lubricant, amongst others, include:

- Operating conditions (speed, accelerations, stroke, load, installation orientation)
- External influences (temperature, aggressive media or radiation, dirt accumulating, moisture)
- Subsequent lubrication (period of time, quantity, compatibility with other lubricants)
- Compatibility (with corrosion protection, with integrated materials such as plastic cages)
- Tracks (geometry, surface roughness, hardness, material, coating, wettability)

Technical and economic considerations determine the lubricant and process to be used. Generally lithium-soap-based roller bearing grease are used to lubricate (alloyed greases KP2K in accordance with DIN 51502 or DIN 51825). Oil dispensers or occasional oiling via oil nipples fully meet the demands of the guideways. For minimal roller frictional resistance lubrication with mineral-oil-based oils is recommended (CLP or HLP in viscosities of ISO VG 15 to 100 in accordance with DIN 51519).

The lubricants are normally applied through the spacing between the linear guideways and the recirculating units or through the lubrication holes in some instances available as standard or lube nipples in the recirculating units. If this is not supported by the design (e.g. in the case of vertical installation), on request linear guideways with lube holes can also be supplied. Particularly advantageous are oil mist lubrication methods, which help to prevent dirt accumulating on the guideways with their slight excess pressure. Their acceptability is greatly limited, however, due to their environmental impact. Cutting-oils or water soluble coolants are to be kept away from the guideways, however, because they dilute or wash away the available lubricant. In addition, coolants tend to stick when drying out. Lubricants with solid additives are inappropriate.

Subsequent lubrication intervals depend on the aforementioned operating conditions and external influences and cannot be therefore be calculated. That is why the lubrication point must be observed over a lengthy period of time.

Values based on historical experience show that with normal use subsequent lubrication of up to 2 to 5 times is sufficient, spread over the calculated service life.

13 Construction and installation guidelines

Lubrication of the recirculating unit NRT

There are three ways of lubricating the NRT

Variant A: Lube nipple on each end face

Variant B: Lube opening on the top

Variant C: Optional connection for a centralised lubricating system

Variant A: Lubrication by means of the lube nipple

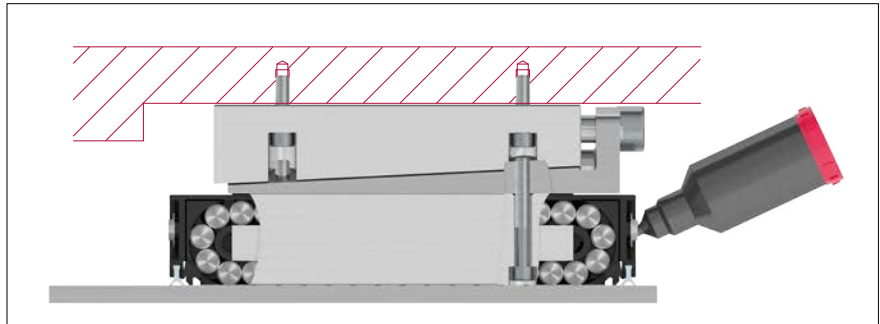

Variants B:

Oil delivery through the lube opening on the top

Oil delivery through the lube opening on the top through the preload wedge NRV

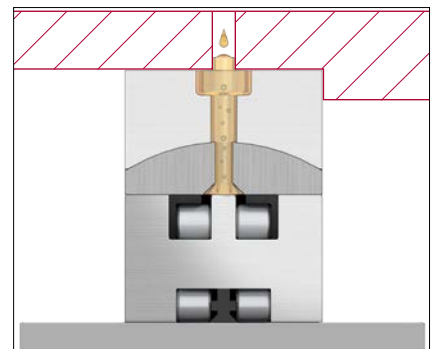
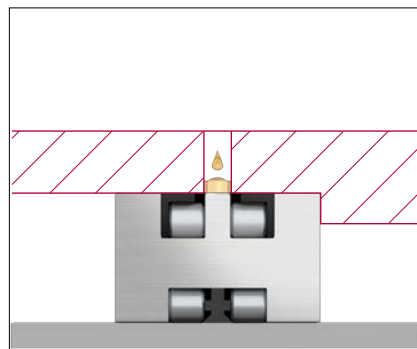

Variant C: Centralized lubricating system (option ZS)

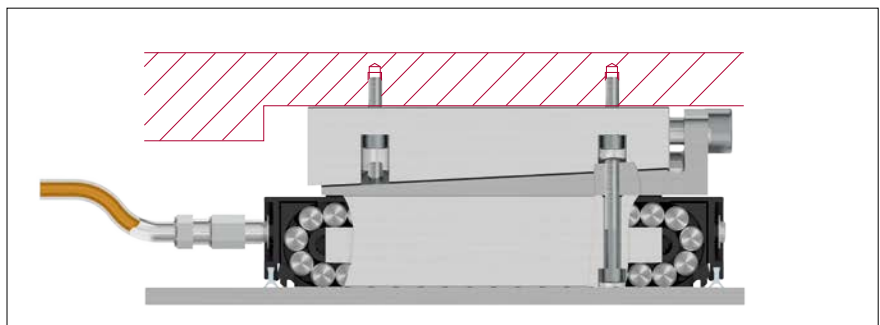

13 Construction and installation guidelines

13.9 Transport, handling and storage

Linear guideways and recirculating units are high-precision components and should therefore be handled with care. They should always be transported in their original packaging to protect them from damage and be stored at room temperature and in a dry environment.

Improper handling of the guideways can lead to preliminary damage and thus to premature failure. That is why their assembly may only be undertaken by expert professional staff.

13.10 Installation guidelines

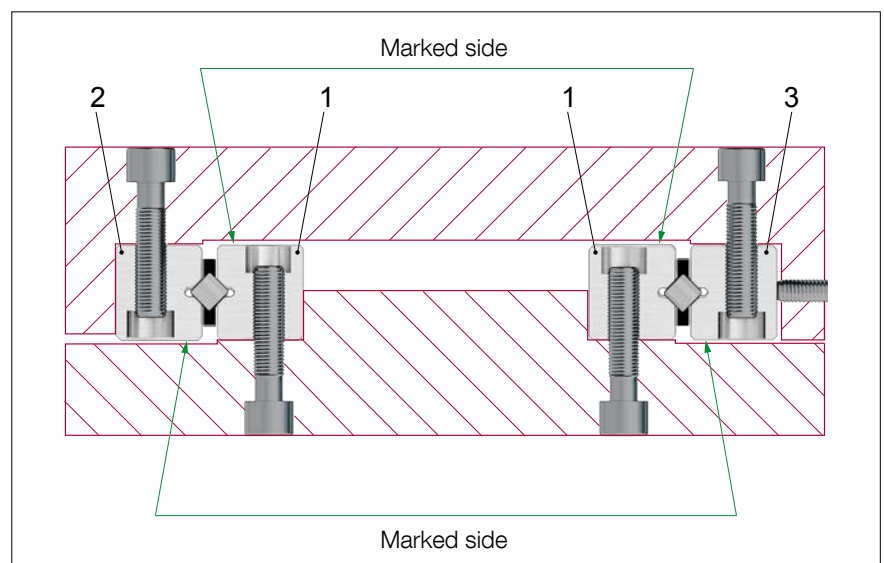

Linear guideways

With careful, clean preparation and a step by step approach, by adopting a rational procedure you will achieve a perfect guide system.

The following installation instructions applies by analogy for all types of SCHNEEBERGER linear guideways.

- To guarantee a perfect support for the guide rails, any remaining burrs or ridges are to be removed with a fine whetstone.
- Before installation, the linear guideways and supporting surfaced should be cleaned. By means of a subsequent light lubrication they will be protected from any consequential damage.

Tip for long or multi-part guide rails:

- Due to the bore hole tolerances of the rails, the fastening holes in the supporting surfaces should be drilled according to the holes in the linear guideways. By using fastening screws with a thin shaft differences in hole spacings can also be evened out (see chapter 5).
- The marked side of the guide rail may not be used as a supporting surface!

13 Construction and installation guidelines

- The fixed pair of linear guideways (1) is pressed against the supports using an appropriate clamping element and the fastening screws are tightened (use a torque wrench! For tightening torque see chapter 13.5.)

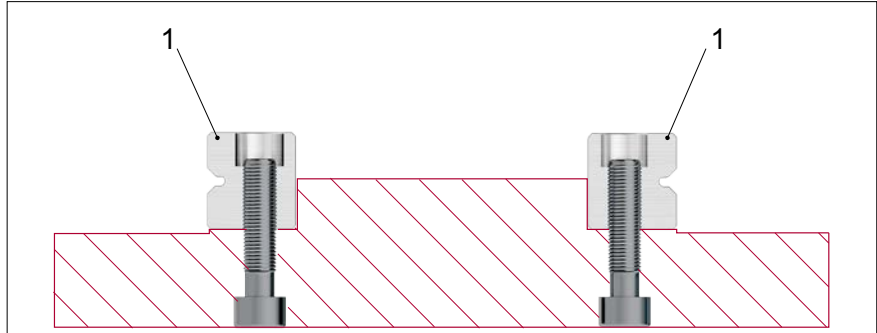

- Check parallelism ΔA and ΔP . The parallelisms measured must fall within the tolerances of the linear guideway (see chapter 7.1)

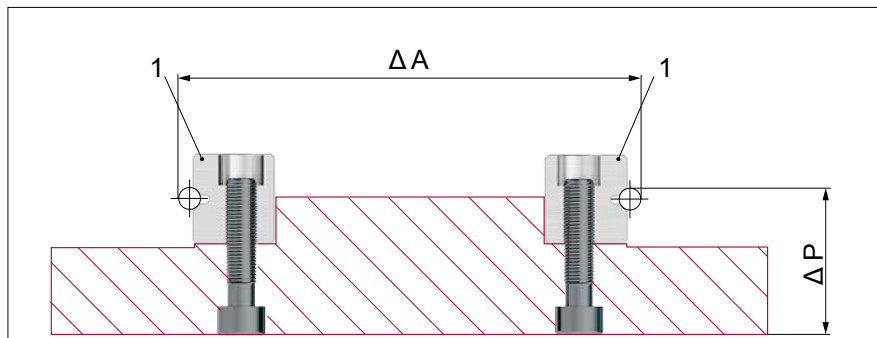

- Install the fixed rail (2) of the opposing pair.

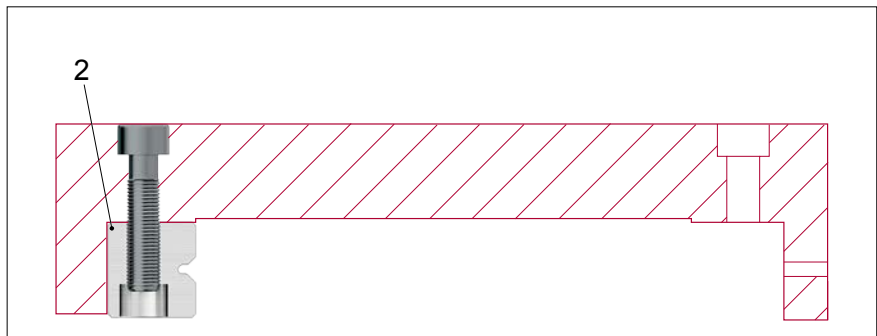

13 Construction and installation guidelines

- Install the rail (3) and in so doing only lightly tighten the fastening screws.
- Lubricating (see chapter 13.8)

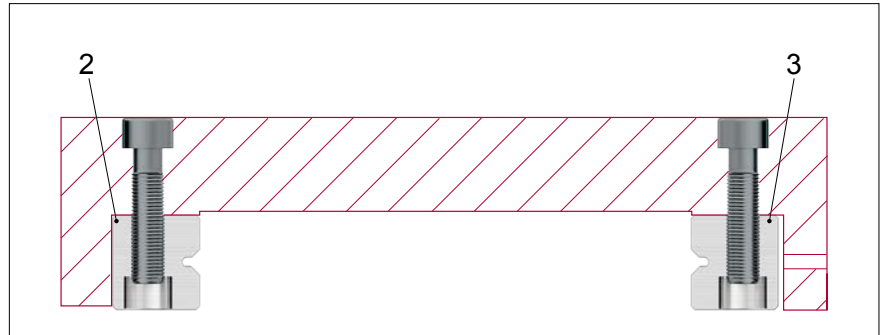

- Insert and center the cages (4). After that the linear bearings must be preloaded (please refer to the following page).

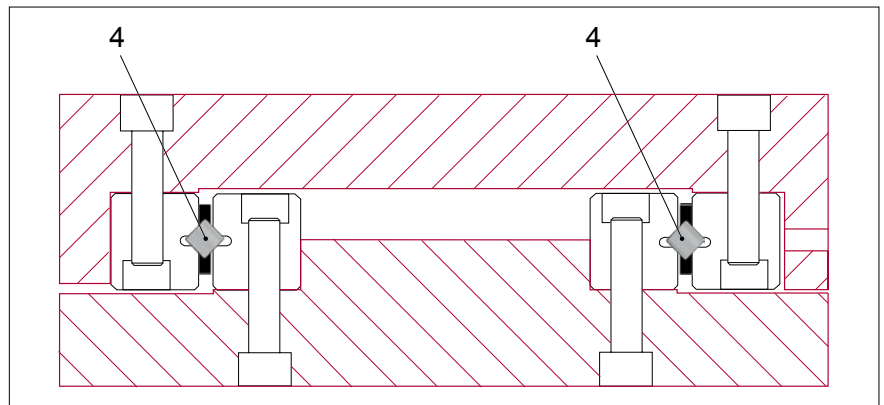

13 Construction and installation guidelines

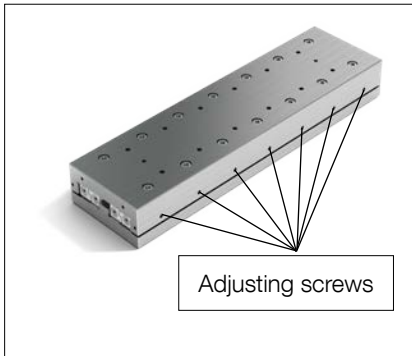

- Set and/or preload the linear guideway with zero-backlash (see chapter 13.5).

Application of the preload using the adjusting screws should be carried out from the centre of the rail outwards using the following steps (the sequence can be worked out from the figures):

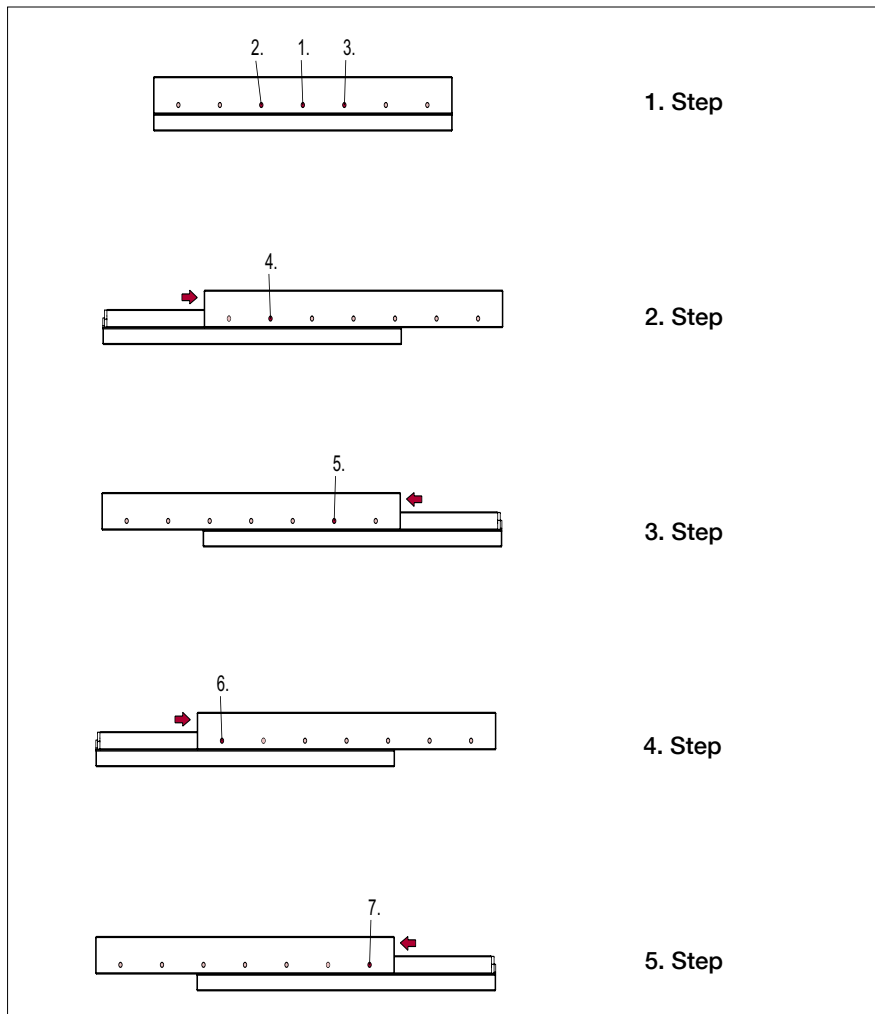

- Tighten the fastening screws for the rail (3).
- Install the end pieces

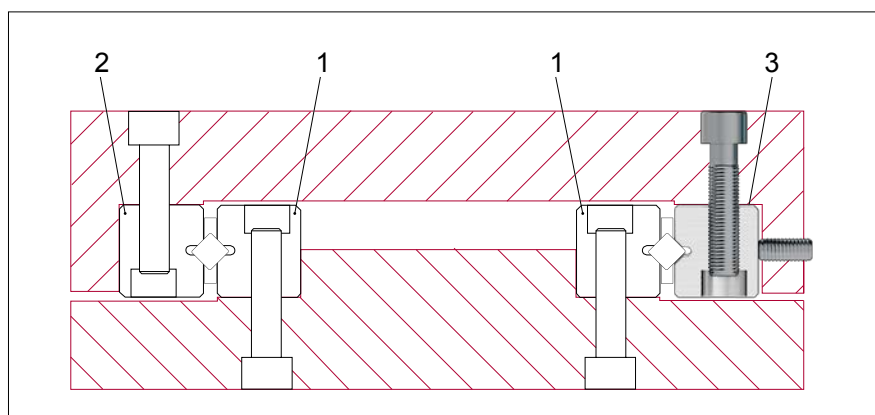

14 Order descriptions

Examples for linear guideways

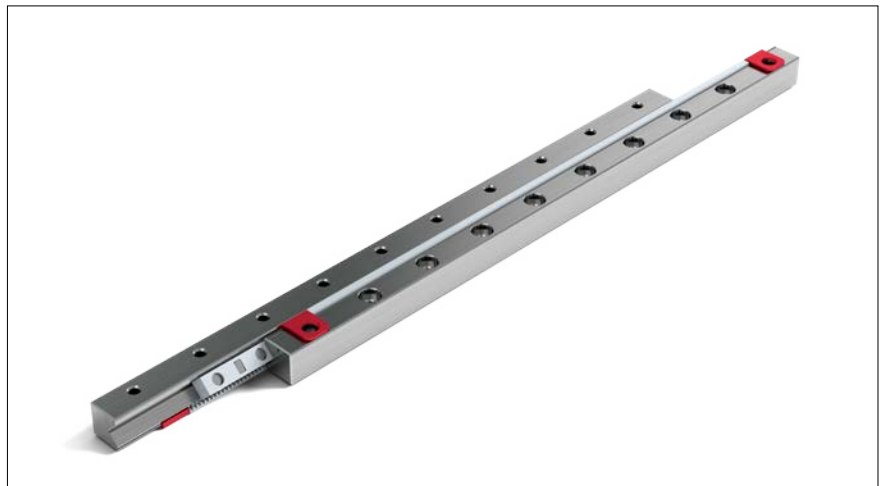

Example 1	Quantity	Type and size	Length in mm	Options
Guide rails	80	RNG 6	- 300	-RF-SSQ-KS
Cage	40	KBS 6 x 20*		-RF

Example 2	Quantity	Type and size	Length in mm	Options
Guide rails	20	R 9	- 800	
Guide rails	20	R 9	- 600	-EG
Cage	20	AC 9 x 22*		
End pieces	40	GC 9		

* corresponds to the number of rolling elements

Note: In the case of cage types HW and SHW the cage length must be indicated in mm!
(e.g. SHW 20 x 155 mm)

Example recirculating unit

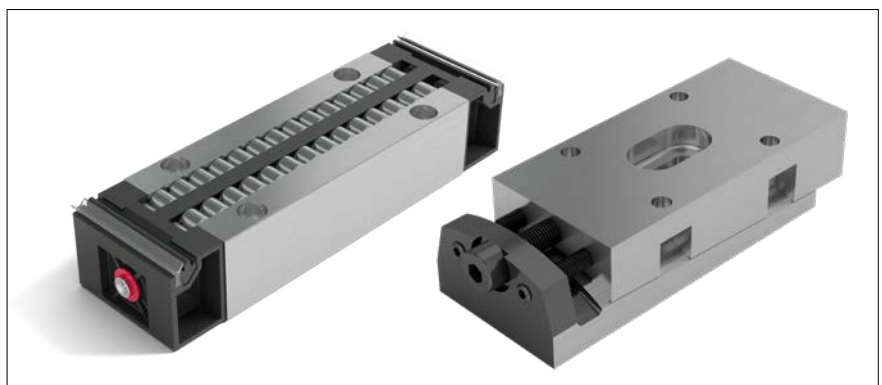

	Quantity	Type and size	Options
Recirculating units	150	NRT 26111	-GP
Preload wedge	150	NRV 26111	

PROSPECTUSES

- COMPANY BROCHURE
- CUSTOMIZED BEARINGS
- GEAR RACKS
- LINEAR BEARINGS and RECIRCULATING UNITS
- MINERAL CASTING SCHNEEBERGER
- MINISLIDE MSQscale
- MINI-X MINIRAIL / MINISCALE PLUS / MINISLIDE
- MONORAIL and AMS profiled linear guideways with integrated measuring system
- MONORAIL and AMS application catalog
- POSITIONING SYSTEMS
- SLIDES



www.schneeberger.com

www.schneeberger.com/contact