



User Manual

PCE-XXM 20 Spectrophotometer



User manuals in various languages (français, italiano, español, português, nederlands, türk, polski, русский, 中文) can be found by using our product search on: www.pce-instruments.com

Last change: 1 August 2019
v1.0



Contents

1	Safety notes	1
2	Working principle	2
3	Technical specifications	3
4	Device description	3
5	Operation	4
5.1	Powering On and Off	4
5.2	Calibration	5
5.3	Comparative measurement	6
5.4	Checking XYZ, RGB, CMYK and Pantone values	6
6	Functions menu	7
6.1	Set time	7
6.2	Set language	8
6.3	Energy saving	9
6.4	Set number of measurements for average calculation	9
6.5	Set tolerance	9
6.6	Set colour formula	9
6.7	USB connection	10
6.8	Bluetooth connection	10
7	Memory	10
8	Charging the battery	10
9	Troubleshooting	11
10	Warranty	12
11	Disposal	12

1 Safety notes

Please read this manual carefully and completely before you use the device for the first time. The device may only be used by qualified personnel and repaired by PCE Instruments personnel. Damage or injuries caused by non-observance of the manual are excluded from our liability and not covered by our warranty.

- The device must only be used as described in this instruction manual. If used otherwise, this can cause dangerous situations for the user and damage to the meter.
- The instrument may only be used if the environmental conditions (temperature, relative humidity, ...) are within the ranges stated in the technical specifications. Do not expose the device to extreme temperatures, direct sunlight, extreme humidity or moisture.
- Do not expose the device to shocks or strong vibrations.
- Avoid corrosive media and heavy dust.
- The case should only be opened by qualified PCE Instruments personnel.
- Never use the instrument when your hands are wet.
- You must not make any technical changes to the device.
- The appliance should only be cleaned with a damp cloth. Use only pH-neutral cleaner, no abrasives or solvents.
- The device must only be used with accessories from PCE Instruments or equivalent.
- Before each use, inspect the case for visible damage. If any damage is visible, do not use the device.
- Do not use the instrument in explosive atmospheres.
- The measurement range as stated in the specifications must not be exceeded under any circumstances.
- This instrument contains a lithium battery. Therefore, avoid high temperatures and strong magnetic environments to protect the battery from damage.
- Non-observance of the safety notes can cause damage to the device and injuries to the user.

We do not assume liability for printing errors or any other mistakes in this manual.

We expressly point to our general guarantee terms which can be found in our general terms of business.

If you have any questions please contact PCE Instruments. The contact details can be found at the end of this manual.

2 Working principle

Tristimulus principle: The light source is reflected at the surface of the object and the colour sensor receives the reflected light. After the digitalisation of the sensor data, the colour coordinates are calculated and can then be used to determine colour deviations between the standard and the sample. To do so, use the colour difference formula below.

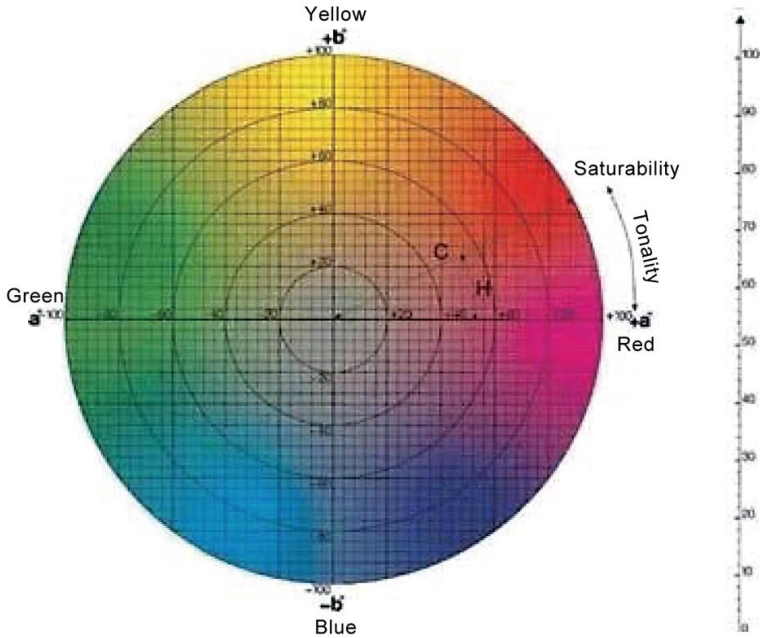

Colour difference formula:

$$\Delta E^* = \sqrt{(\Delta L^*)^2 + (\Delta a^*)^2 + (\Delta b^*)^2}$$

ΔE^* = the total colour difference

ΔL = L^* standard - L^* samples

Δa = a^* standard - a^* samples

Δb = b^* standard - b^* samples

$\Delta L+$ = more white

$\Delta a+$ = more red

$\Delta b+$ = more yellow

$\Delta L-$ = more dark

$\Delta a-$ = more green

$\Delta b-$ = more blue

Classification of colour difference ranges

ΔE	Classification
0 ... 0.5	Minor difference
0.5 ... 1.0	Small to medium difference, acceptable in some applications
1.0 ... 2.0	Medium difference, acceptable in some applications
2.0 ... 4.0	Large difference, acceptable for specific applications
4.0	Very large difference, unacceptable

Explanation: Colour differences are classified differently depending on the industry. Please familiarise with the industry-specific requirements.

3 Technical specifications

Color space	CIELAB CIEXYZ RGB, Pantone, CMYK
Color difference formula	ΔE^*_{Lab} (CIE76/CIE94)
Measuring aperture	Ø 8mm
Measuring geometry	45°/diffused illumination
Type of light source	LED
Sensor	RGB silicon photoelectric diode
Viewing angle	CIE 10°Standard angle
Measurement interval	1.5 s
Battery	Li-ion battery, chargeable via USB
Operating conditions	0 ... 40 °C <80 %
Storage conditions	10 ... 30 °C <70 %

4 Device description

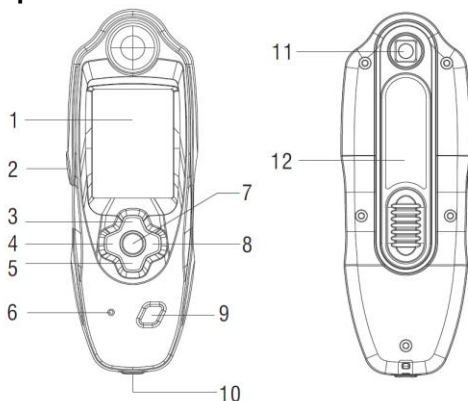

1. LC display

Shows colour information, status and options

2. MEAS button

Press to measure

3. Up button

Move cursor up

4. Left button

Move cursor left

5. Down button

Move cursor down

6. Speaker

For beeping sound

7. MEAS/ENTER button

Selects menu items and shows notes

8. Right button

Move cursor right

9. Power button

Turns instrument on and off

10. USB port

For charging and software connection

11. Measurement optics

Illumination of measuring area, colour measurement

12. White reference slider

Positions the calibration tile for measurement or calibration/storage

Front, side and rear view

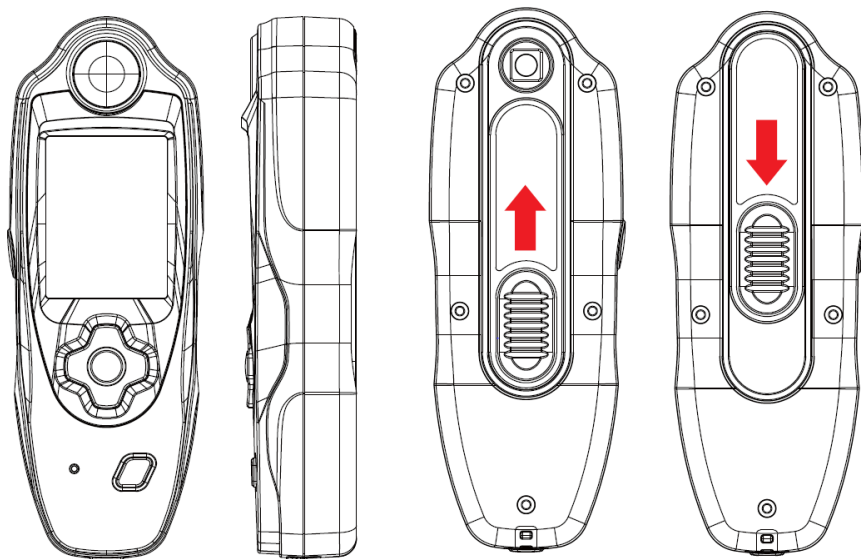

5 Operation

5.1 Powering On and Off

Turn on the instrument by pressing the Power button. The start screen looks as follows:



To turn off the meter, press the Power button again.

5.2 Calibration

When your instrument is first turned on, you should perform a calibration. Thereafter, a calibration is required every hour or if a 5 °C temperature change has occurred. Calibration of the instrument ensures optimum colour matching performance.

1. Move the white reference slider to the closed/calibration position over the optics.
2. Power on the instrument, then go the "Calibration" menu (left button – down button until cursor is on "Calibration" – confirm with MEAS/ENTER). The display will show the following:



3. Use the arrow keys to select "StandWhite" and press MEAS to initiate the calibration.
4. Open the optics and align the measuring aperture in the air without aligning it directly with a light source. Go to the "Calibration" menu and select "StandZero". Then press the MEAS key to carry out the calibration.
5. If the calibration was successful, "StandWhite" or "StandZero" will be ticked. If not, there will be an "X" instead.
6. Make sure to always reposition the slider back to "Measure" location (optics opened) before making a measurement.

Note: The calibration reference is dramatically affected by smudge marks and dust and must be kept clean. It is recommended that the instrument is cleaned regularly.

5.3 Comparative measurement

Power on the instrument, initiate a calibration and then do measurement on selected standard sample (Select standard from main menu – Standard or use your own standard). Press button MEAS or MEAS/ENTER to measure and get the measurement result as shown in photo 1. If the measurement has already been made or if the measuring time was too short, an error message will appear. The result will be shown as in photo 1. When the value has stabilised, press right button to view more results as in photo 2. Then measure your desired sample by pressing MEAS or MEAS/ENTER.

S = standard measurement value
 B = sample reading
 ΔE = overall colour difference

The meter will then compare the test results and either show “Pass” (photo 2.1, high conformity) or “Fail” (photo 2.2, low conformity).

The three mentioned values will be saved to the memory automatically.



Photo 1



Photo 2

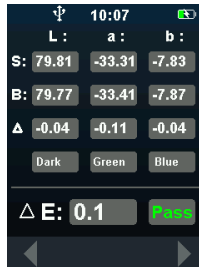

Photo 2.1



Photo 2.2

5.4 Checking XYZ, RGB, CMYK and Pantone values

After a measurement, when the display looks as in photo 1, press the up or down key to check the XYZ, RGB, CMYK or Pantone value (as shown in photo 2).



Photo 1



Photo 2

6 Functions menu

After powering on, press the left key to enter the main menu that looks as follows:



6.1 Set time

In the “Settings” menu, press the up and down keys to select “DateTime” and confirm with MEAS/ENTER. Go to the respective menu items by using the up and down keys and press MEAS/ENTER to be able to change the values. Set the hours and then the minutes by using the arrow keys. The seconds cannot be changed. Confirm the individual entries with the MEAS/ENTER key.

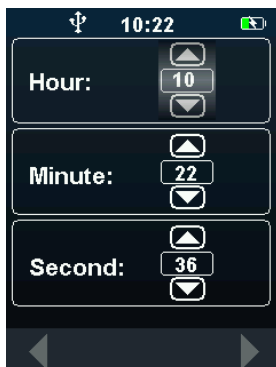



6.2 Set language

In the main menu, go to "Settings" by pressing the up and down keys and confirm with MEAS/ENER. The display will show the following:



On this page, select "MeterSetup" in the same way to enter the following page:

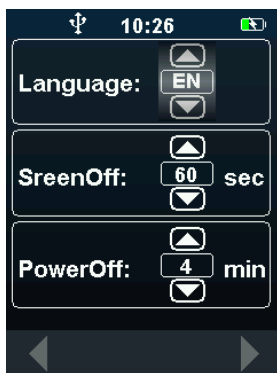

Confirm with MEAS/ENTER. You can then change the language (English or Chinese) with the up and down keys. After making your selection, confirm with MEAS/ENTER.

6.3 Energy saving

To save energy, you can set a time after which the display backlight or the device itself switches off automatically. When you are in the main menu, use the up and down keys to select “Settings” and confirm with the MEAS/ENTER key. Then select “MeterSetup” with the arrow keys and confirm with MEAS/ENTER again get to the respective submenus.

These submenus SreenOff and PowerOff can be opened with the MEAS/ENTER key. Changes can be made by using the up and down keys and confirmed with MEAS/ENTER.

The following can be selected:

SreenOff: 1 ... 99 seconds

PowerOff: Off (No), 10, 20, 30 minutes

6.4 Set number of measurements for average calculation

In the “Settings” menu, select “MeasSetup” with the up and down keys and confirm with MEAS/ENTER. Go to the menu item “AverTime” by using the up and down keys and press MEAS/ENTER. Now set the desired number of measurements you want to be included in the average calculation with the up and down keys and confirm with MEAS/ENTER.

6.5 Set tolerance

In the “Settings” menu, select “MeasSetup” with the up and down keys and confirm with MEAS/ENTER. Go to the menu item “DeSetting” by using the up and down keys and press MEAS/ENTER. Now set the desired tolerance with the up and down keys and confirm with MEAS/ENTER. A tolerance of 1.0 is preset.

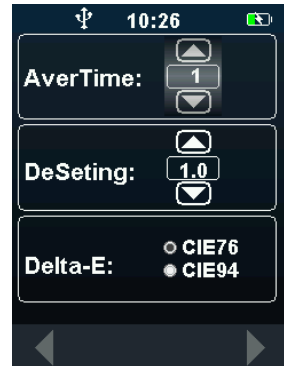
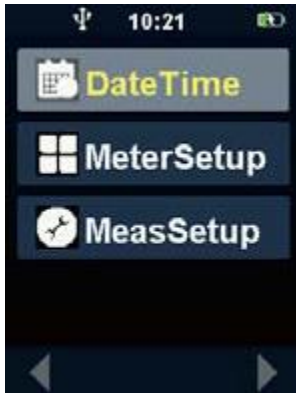

6.6 Set colour formula

In the “Settings” menu, select “MeasSetup” with the up and down keys and confirm with MEAS/ENTER. Go to the menu item “Delta-E” with the down key and press MEAS/ENTER. Now select the desired colour formula (CIE76 or CIE94) by using the up and down keys and confirm with MEAS/ENTER.



6.7 USB connection

Connect the meter to your computer by using the Micro USB cable. The colour meter is recognised as a HID device and all drivers will be installed automatically. When the installation is completed, the PCE-XXM 20 will be recognised as follows:

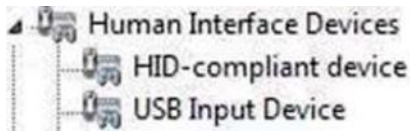

Download the PC software from the following link:

https://www.pce-instruments.com/english/download-win_4.htm

Install and start the software. Further instructions can be found in the help file of the software.

Note:

The meter can only connect to the software if the USB icon is shown in the upper left part of the display.

6.8 Bluetooth connection

Connect the instrument to smartphone via Bluetooth to transfer the measuring data to the Android or iOS app.



7 Memory

The colour meter has memory capacity for up to 20 groups of data (S = standard measurement value, B = sample reading, DE = overall colour difference) which are saved automatically after a comparative measurement. In order to read out the memory, go to the menu item “DataLog” in the main menu and confirm with the MEAS/ENTER key. To view a group of data, select it by means of the up and down keys and confirm your selection with MEAS/ENTER. With the arrow right key, you can delete the selected individual group of data. To delete all groups of data, select “Delete All” from the overview and confirm with MEAS/ENTER.

Note:

When clearing the complete memory, you will not be asked to confirm that you wish to delete all data.

8 Charging the battery

Before using the colorimeter for the first time, it is important that you fully charge the battery. Otherwise, the internal lithium-ion battery may experience a shortened life.

The meter can be charged when switched off or when switched on. However, operation during charging is not possible. Connect the supplied USB cable or a USB cable of the same type to the colour meter and to your computer's USB port. If the meter is on, you will see this icon  when the meter is charging. A full charge of a completely empty battery will take approx. 6 hours.

Battery icon information



fully charged



half charged - sufficient for a substantial number of measurements



low - measurements still possible but battery should be charged soon



charging.

9 Troubleshooting

Variables that may affect the measuring results and should be avoided include:

- Sensor blocked
- Environmental temperature too low – slow display reaction, limited accuracy
- Improper use of the instrument or unsuitable sample:
 - The instrument does not lie flat on the sample.
 - The sample has an uneven texture.
 - The sample is dirty.
 - The sample contains fluorescent, metallic, or pearlescent colorants.
 - The sample looks different when viewed at different angles.



10 Warranty

You can read our warranty terms in our General Business Terms which you can find here: <https://www.pce-instruments.com/english/terms>.

11 Disposal

For the disposal of batteries in the EU, the 2006/66/EC directive of the European Parliament applies. Due to the contained pollutants, batteries must not be disposed of as household waste. They must be given to collection points designed for that purpose.

In order to comply with the EU directive 2012/19/EU we take our devices back. We either re-use them or give them to a recycling company which disposes of the devices in line with law.

For countries outside the EU, batteries and devices should be disposed of in accordance with your local waste regulations.

If you have any questions, please contact PCE Instruments.



PCE Instruments contact information

Germany

PCE Deutschland GmbH
Im Langel 4
D-59872 Meschede
Deutschland
Tel.: +49 (0) 2903 976 99 0
Fax: +49 (0) 2903 976 99 29
info@pce-instruments.com
www.pce-instruments.com/deutsch

Germany

Produktions- und
Entwicklungsgesellschaft mbH
Im Langel 26
D-59872 Meschede
Deutschland
Tel.: +49 (0) 2903 976 99 471
Fax: +49 (0) 2903 976 99 9971
info@pce-instruments.com
www.pce-instruments.com/deutsch

The Netherlands

PCE Brookhuis B.V.
Institutenweg 15
7521 PH Enschede
Nederland
Telefoon: +31 (0)53 737 01 92
Fax: +31 53 430 36 46
info@pcebenelux.nl
www.pce-instruments.com/dutch

United States of America

PCE Americas Inc.
711 Commerce Way suite 8
Jupiter / Palm Beach
33458 FL
USA
Tel: +1 (561) 320-9162
Fax: +1 (561) 320-9176
info@pce-americas.com
www.pce-instruments.com/us

France

PCE Instruments France EURL
23, rue de Strasbourg
67250 Soultz-Sous-Forêts
France
Téléphone: +33 (0) 972 3537 17
Numéro de fax: +33 (0) 972 3537 18
info@pce-france.fr
www.pce-instruments.com/french

United Kingdom

PCE Instruments UK Ltd
Unit 11 Southpoint Business Park
Ensign Way, Southampton
Hampshire
United Kingdom, SO31 4RF
Tel: +44 (0) 2380 98703 0
Fax: +44 (0) 2380 98703 9
info@industrial-needs.com
www.pce-instruments.com/english

Chile

PCE Instruments Chile S.A.
RUT: 76.154.057-2
Calle Santos Dumont N° 738, Local 4
Comuna de Recoleta, Santiago
Tel. : +56 2 24053238
Fax: +56 2 2873 3777
info@pce-instruments.cl
www.pce-instruments.com/chile

Turkey

PCE Teknik Cihazları Ltd.Şti.
Halkalı Merkez Mah.
Pehlivan Sok. No.6/C
34303 Küçükçekmece - İstanbul
Türkiye
Tel: 0212 471 11 47
Faks: 0212 705 53 93
info@pce- cihazlari.com.tr
www.pce-instruments.com/turkish

Spain

PCE Ibérica S.L.
Calle Mayor, 53
02500 Tobarra (Albacete)
España
Tel. : +34 967 543 548
Fax: +34 967 543 542
info@pce-iberica.es
www.pce-instruments.com/espanol

Italy

PCE Italia s.r.l.
Via Pesciatina 878 / B-Interno 6
55010 Loc. Gragnano
Capannori (Lucca)
Italia
Telefono: +39 0583 975 114
Fax: +39 0583 974 824
info@pce-italia.it
www.pce-instruments.com/italiano

Hong Kong

PCE Instruments HK Ltd.
Unit J, 21/F., COS Centre
56 Tsun Yip Street
Kwun Tong
Kowloon, Hong Kong
Tel: +852-301-84912
jyi@pce-instruments.com
www.pce-instruments.cn

China

PCE (Beijing) Technology Co., Limited
1519 Room, 6 Building
Zhong Ang Times Plaza
No. 9 Mentougou Road, Tou Gou District
102300 Beijing
China
Tel: +86 (10) 8893 9660
info@pce-instruments.cn
www.pce-instruments.cn