

FEATURES

- Rectangular Active Area
- Excellent Stability after EUV Exposure
- Windowless Package for Responsivity to 1 nm
- Ceramic Package

Electro-Optical Characteristics at 25 °C

Parameters	Test Conditions	Min	Typ	Max	Units
Active Area	22.05 mm x 15.85 mm		331		mm ²
Responsivity	See attached graph				A/W
Shunt Resistance	@ ± 10 mV	5			MOhms
Reverse Breakdown Voltage, V _R	I _R = 1 μA	20	25		Volts
Capacitance, C	V _R = 0 V			40	nF
Response Time, tr	RL = 50 Ω, V _R = 0 V			10	usec

Thermal Parameters

Storage and Operating Temperature Range	Units
Ambient	-10 ° to 40 °C
Nitrogen or Vacuum	-20 ° to 80 °C
Maximum Junction Temperature	70 °C
Lead Soldering Temperature ¹	N/A

¹ Soldering not recommended. Use with AXUV300CTS socket or equivalent.

Typical Photon Responsivity

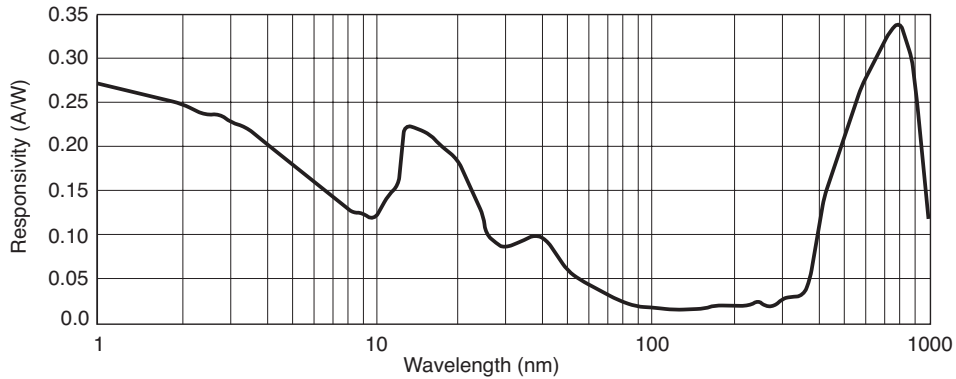

Package Information

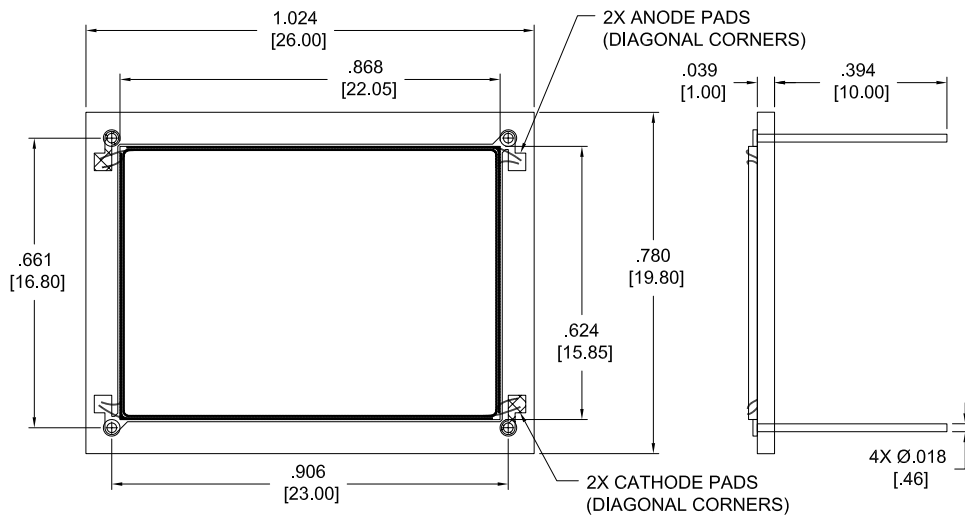

Dimensions are in inch [metric] units.

Specifications are subject to change without prior notice.