

SMA Terminated Laser Module

Item Number ST-115-976-105-1-1.5-SMA-R01
Item Description DIRECT DIODE 115W SPECIFICATION

ECCN: EAR99 ¹

	Units	Lower Spec	Typical	Upper Spec
Optical				
CW Output Power (in fiber)	W		115	
CW Output Power (as measured)	W	99	111	
Wavelength Centroid	nm	975	976	977
Spectral Width (FWHM)	nm		0.7	1.0
Power within 0.17 NA	%		95	
Fiber Core / Clad Diameter	um		105 / 125	
Fiber NA / Index Type	-		0.22 NA / Step Index	
Electrical				
Electrical-to-Optical Efficiency	%		38	
Threshold Current	A			1
Operating Current	A		14.0	14.0
Operating Voltage	V		21.4	22.5
Wavelength Stabilized Operating Current	A	12.0		16.0
Mechanical				
Mass ³	g		440	
Fiber Length	m	1.5	2.0	2.1
Fiber Bend Radius (Active / Storage)	mm	25		
Fiber Jacketing	-		Stainless Steel or Hytrel	
Fiber Termination	-		SMA	
Thermal				
Thermal Resistance ⁴	C/W		0.3	
Waste Heat	W		185	
Operating (Housing) Temperature ²	°C		+30	
Wavelength Temperature Coefficient	nm / C		0.01	
Wavelength Current Coefficient	nm / A		N/A	

Outline Drawing

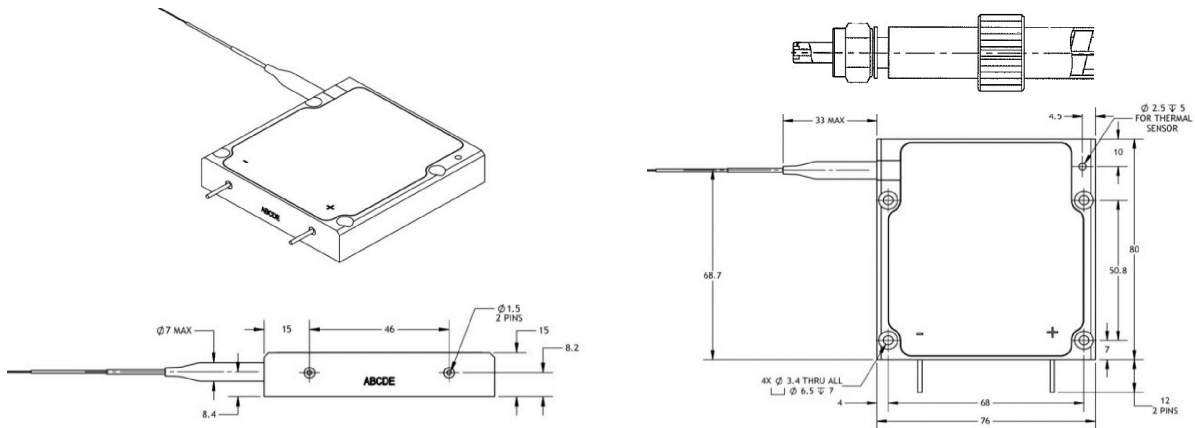

Notes

- ¹Export Control Classification Number (ECCN) as defined by the Export Administration Regulations (EAR)
- ²Operating temperature defined by the water temperature and ambient temperature. Acceptable operating range is 20 - 35C, but performance may vary
- ³Does not include mass of fiber
- ⁴Clean water with 100um filter



819 SE 14th Loop, Suite 101K - Battle Ground WA 98604 USA
www.sakartek.com - sales@sakartek.com