

SBIG® STC-7

Take stunning astrophotos with this all-inclusive imaging package. The SBIG STC-7 features an ultra-sensitive and low noise 7 megapixel cooled CMOS sensor, integrated 8 position filter wheel, plus a complete set of LRGB and narrowband filters, and an opaque filter for convenience in making dark frames.



Get stunning images on your first night. You can easily connect the STC-7 to your telescope via either the front T-Thread mount or the included 2" focuser adapter. The integrated filter wheel design ensures minimal back-focus distance for maximum compatibility with modest-sized refractors, and small catadioptric or Newtonian telescopes.

The STC-7 package also includes MaxIm LT for Windows – all the software you need to take images, calibrate, stack, and do essential image processing. Other software is supported via included ASCOM drivers. Mac OS and Linux drivers are also available.

For even better results, the STC-7 is compatible with our SBIG StarChaser SC-2 off-axis guide camera for accurate guiding of your telescope. The StarChaser also supports the SBIG AO-8A adaptive optics accessory, which helps you get pinpoint star images.

FEATURES AND BENEFITS

The SBIG STC-7 camera highlights:

High sensitivity, low noise 7.1 megapixel Sony IMX428 imaging sensor for results in less time	SmartCooling™ active temperature regulation to 0.1°C for high calibration stability
Electronic global shutter for fast exposure times (0.001 to 3600 s) for bright and faint targets	Integrated 8-Position Filter Wheel with LRGB + H-alpha, OIII, and SII filters, plus an opaque filter for dark frames. No need to buy extras
High-speed USB 3.0 interface and USB 2.0 compatible for longer cables	Compatible with SBIG StarChaser SC-2 off-axis guiding camera for precise star tracking
Downloads in under 90 milliseconds (depending on computer speed)	Supports AO-8A adaptive optics unit via StarChaser SC-2 makes real-time corrections
StackPro™ automatic in-camera sub-exposure stacking saves disk space	MaxIm LT control software so you are ready to go on the first night
Regulated two-stage cooling with delta T of -30°C for low noise on warm nights	Multiplatform software API and sample code available for software developers

SBIG STC-7

TECHNICAL SPECIFICATIONS

A/D Converter	12-bit with dual gain modes
Adaptive Optics Option	AO-8A via StarChaser SC-2
Binning Modes	1×1, 2×2
Computer Interface	USB 3.0, USB 2.0 compatible
Cooling Delta	Approximately 30°C
Dark Current	0.1 e-/p/s at -5°C
Exposure	0.001 – 3600 s
Filter Wheel	Built-in 8 position, 7 quality filters included
Full Frame Download	<90 ms
Imaging / Pixel Array	3208 x 2200 pixels
Imaging Sensor	Sony IMX428 CMOS sensor
Off-Axis Guider	StarChaser SC-2 recommended option
Peak QE	78% typical
Pixel Size	4.5 x 4.5 μm
Power	12VDC, 4A max
Read Noise (Typical)	1.9 e- High Gain, 2.5 e- Med Gain, 5 e- Low Gain
Sensor Size	14.4 mm X 9.9 mm
Shutter	Global Shutter (electronic), Opaque Slot on Filter Wheel for Dark Frames
Temperature Regulation	Yes
Total Pixels	7.1 megapixel

OPTIONAL ACCESSORIES

SBIG AO-8A Adaptive Optics

StarChaser SC-2 / AO-8A Bundle

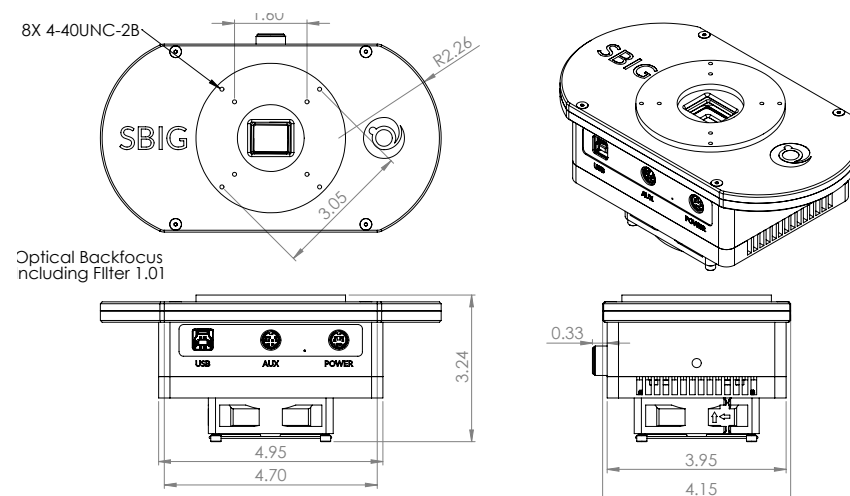

 **SBIG**® IMAGING SYSTEMS

DIFFRACTION LIMITED

59 Grenfell Cr., Unit B,
Ottawa, ON K2G 0G3
Canada
+1-613-225-2732

diffractionlimited.com

ORDER THE SBIG SCIENTIFIC CAMERA OF YOUR DREAMS THIS YEAR FROM OUR WORLDWIDE NETWORK OF DEALERS

Specifications subject to change without notice – January 2021

SBIG®, Aluma®, and Cyanogen Imaging® are registered trademarks of Diffraction Limited. StarChaser, ST-4, STXL, STX, MaxIm DL, MaxIm LT are trademarks of Diffraction Limited. All other trademarks, service marks, and trade names are the property of their respective owners.