

**SBIG®**  
**STC-428-OEM**

**SBIG STC-428-OEM SCIENTIFIC CMOS  
IMAGING CAMERA EVALUATION PACKAGE.**

The STC-428 is designed to be used as a component in instruments for medical imaging, laboratory instruments, low-light industrial inspection, and other applications. The basic camera platform can be modified to meet your mechanical requirements including mounting, packaging, accessories, and more. Options such as a mechanical shutter or filter wheel can be added. Software API support is provided for a variety of operating systems including embedded Linux applications.



For years mature CCD sensor technology, embodied in our venerable STF-8300-OEM camera, set the standard for high sensitivity, low noise, high dynamic range, and images free of pattern noise.

The new STC-428-OEM scientific CMOS camera represents a major improvement over CCD technology. Compared with previous CCD models, the STC-428-OEM features higher sensitivity (78% QE versus 56%), significantly lower read noise (2.5 e- versus 9.3 e-), and 20X faster readout.

While a single exposure on the Sony IMX428 sensor can equal CCD dynamic range, the combination of fast readout and very low read noise allows for stacking many shorter to produce greater dynamic range than previously possible. The built-in StackPro™ capability can automatically divide your exposure into up to 16 shorter sub-exposures, and stack them inside the camera prior to download. This increases dynamic range without imposing greater processing requirements on the host computer.

Our SmartCooling™ active regulation maintains the sensor temperature to within 0.1°C, and minimizes fan speed based on heat sink temperature for longer life and quieter operation.

## FEATURES AND BENEFITS

The SBIG STC-428-OEM features include:

High sensitivity, low noise 7 megapixel Sony IMX428 imaging sensor	SmartCooling™ active temperature regulation to 0.1°C for high calibration stability
Electronic global shutter for fast exposure times (0.001 to 3600 s)	Application engineering support
High-speed USB 3.0 interface (USB 2.0 compatible)	Customization options for your application, including mechanical shutter, filter wheel, packaging modifications, adapters
Downloads in under 90 milliseconds (depending on computer speed)	Accepts Nikon and Canon EOS lens adapters
StackPro™ automatic in-camera sub-exposure stacking	Windows-based evaluation software available
Regulated two-stage cooling with delta ~ -30°C	Multiplatform software API and sample code available

SBIG MODEL NAME	STC-428-OEM
A/D Converter	12-bit with High Gain / Low Gain modes
Binning Modes	1x1, 2x2
Computer Interface	USB 3.0 (USB 2.0 compatible)
Cooling Delta	30°C
Dark Current	0.1 e-/p/s at -5°C
Exposure	0.001 – 3600 s
Full Frame Download	90 ms
Imaging / Pixel Array	3208 x 2200 pixels
Imaging Sensor	Sony IMX428 CMOS sensor
OS Compatibility	Windows 7, 8, 10 x86/x64, MacOS 10.14 “Mojave” x86 binaries, Ubuntu 18.04 LTS x64, Raspbian Buster armhf, Ubuntu MATE arm64
Peak QE	78% typical
Pixel Size	4.5 x 4.5 $\mu$ m
Power	12VDC, 4A max
Read Noise (Typical)	1.9 e- High Gain, 2.5 e- Med Gain, 5 e- Low Gain
Sensor Size	14.4 mm X 9.9 mm
Shutter	Global Shutter (electronic)
Temperature Regulation	Yes
Total Pixels	7.1 megapixel

**SENSOR SPECIFICATIONS**

17.6 mm diagonal

Typical QE:

- Red (635-700 nm) ~ 63%
- Green (520-560 nm) ~ 78%
- Blue (450-490 nm) ~ 75%

80 dB dynamic range

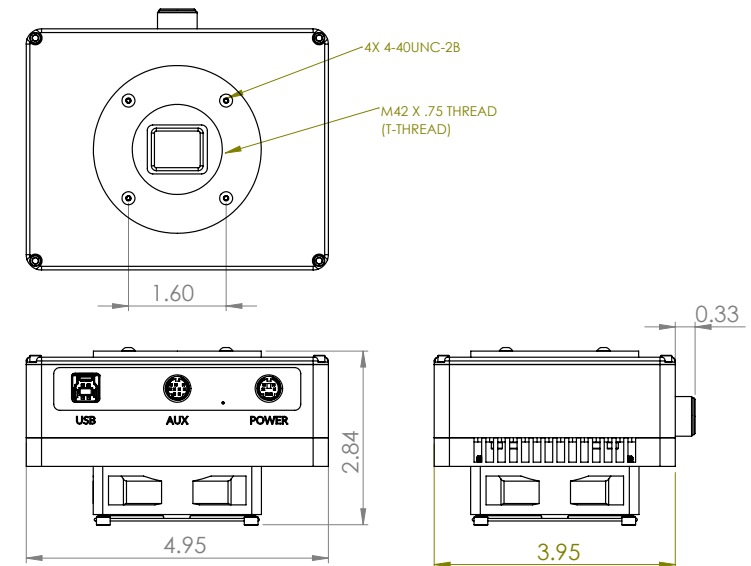

DIFFRACTION LIMITED

 59 Grenfell Cr., Unit B,  
Ottawa, ON K2G 0G3  
Canada  
+1-613-225-2732

[diffractionlimited.com](http://diffractionlimited.com)

ORDER THE SBIG SCIENTIFIC CAMERA OF YOUR DREAMS THIS YEAR FROM OUR WORLDWIDE NETWORK OF DEALERS

Specifications subject to change without notice – January 2021

SBIG®, Aluma®, and Cyanogen Imaging® are registered trademarks of Diffraction Limited. StarChaser, ST-4, STXL, STX, MaxIm DL, MaxIm LT are trademarks of Diffraction Limited. All other trademarks, service marks, and trade names are the property of their respective owners.