

RIO PLANEX™ Series 1550nm Low Phase Noise Narrow Linewidth External Cavity Laser

Key features

- Single longitudinal mode
- Center wavelength: 1530nm-1565nm, ITU -T DWDM 100 GHz C-band or custom
- Very narrow linewidth, long coherence length
- Very low phase noise
- Wavelength tunability
- Ultra low RIN
- Excellent SMSR
- Excellent wavelength stability over life and temperature
- Low sensitivity to vibration and acoustic noise
- CW, modulated and pulsed operations
- Small form factor, 14 pin butterfly
- Low power dissipation
- SMF and PM fiber pigtail options
- Telcordia GR-468 qualified
- RoHS compliant

Applications

- Acoustic & seismic interferometric fiber optic sensing
- Defense and security
- Oil & Gas – exploration and production
- LIDAR
- Metrology
- RF and microwave photonics
- Coherent Communications

Data Sheet
September 2012



Description

The RIO019x Series devices are high-performance cost effective External Cavity Laser (ECL). The design is based on RIO's proprietary planar technology (**PLANEX™**) and consists of a gain chip and a planar lightwave circuit including waveguides with Bragg gratings, forming a laser cavity with significant advantages.

PLANEX™ laser combines high performance, comparable with long cavity fiber lasers, with the low cost, simplicity, small size and reliability of semiconductor lasers.

PLANEX™ laser is an ideal source for multiple commercial and military fiber optic sensors applications, including interferometric and Brillouin DTSS systems for oil & gas, security and smart infrastructures monitoring, coherent Doppler LIDAR for wind measurements, coherent and heterodyne metrology, photonic velocimetry and vibrometry, and coherent communications. Laser is available with various wavelength, phase noise and output power options.

Absolute Maximum Ratings

Operation of the device beyond these maximum conditions may degrade device performance, lead to device failure, shorter lifetime, and will invalidate the device warranty.

Parameter	Min	Max	Unit
Storage temperature	- 40	+ 85	°C
Laser diode reverse voltage		1.2	V
Laser diode forward current		250	mA
Monitor diode reverse voltage		15	V
Monitor diode forward current		25	mA
TEC current		1.5	A
TEC voltage		4.0	V
ESD-susceptibility		500	V
Fiber bend radius	35		mm
Tensile strength, fiber to the package		5	N

Optical and Electrical Specifications

At recommended TEC set temperature T_s and bias current I_b

Parameter	Symbol	Conditions	Min	Typ	Max	Unit
TEC set Temperature	T_{set}	Specified for every laser	15		50	°C
Output Power ¹	P_{out}	CW	see ordering information page			mW
Threshold current	I_{th}	@ T_{set}		10	15	mA
Laser Bias Current	I_b	CW, P_{out}		120	200	mA
Laser Forward Voltage	V_f	CW, @ 100mA		1.6	2	V
Center Wavelength (ITU grid)	λ	± 40 pm standard ²	1530		1565	nm
Side Mode Suppression Ratio	SMSR	CW, at specified P_{out}	40			dB
Wavelength vs. TEC Temperature	$d\lambda/dT$	$T_{set} \pm 2^\circ\text{C}$		12		pm/°C
Wavelength tunability ³	$\Delta\lambda_T$	via TEC temperature change	30			pm
Relative Intensity Noise	RIN	$\geq 1\text{kHz}$			-140	dB/Hz
		$\geq 500\text{kHz}$	Shot noise limited			
Polarization Extinction Ratio ⁴	PER	For PM option, polarization and connector key aligned to slow axis	20			dB
Monitor bias voltage	V_R	Cathode positive to anode	4.75	5	5.25	V
Monitor diode current	I_{mc}	P_{out}	0.05		1	mA
Monitor diode dark current	I_{md}	$V_R = 5\text{V}$			5	nA
Modulation bandwidth			1			GHz
Input Impedance	Z_0			25		Ohm
Optical Isolation	ISO		40			dB

1. Please refer to ordering information page for output power specification
2. Customized wavelength, including ITU-T C-band and wavelength setting tolerance are available. See ordering information.
3. Phase continuous wavelength tuning by changing TEC temperature. Some performance parameters will change over tuning range. Contact RIO for additional information.
4. With PM-fiber PANDA option. See ordering information page

Linewidth and Phase Noise Specifications

At recommended TEC set temperature T_s and bias current I_b ,

Parameter	Symbol	Conditions	Grade 1	Grade 3	Grade 4	Unit
Spectral Linewidth, FWHM ¹	$\Delta\lambda_L$		≤ 15	≤ 5	≤ 2	kHz
Phase Noise Typical Values ²	PhN	@ 10 Hz	123	41	20	$\mu\text{rad}/\text{rt-Hz}$ 1 m OPD
		@ 200 Hz	22	8	4	

1. values based on Lorentzian linewidth model.
2. As measured with RIO's interferometric phase noise test setup, 1m OPD in the SM fiber.

Thermal Specifications

Rev.0.2.0
 Proprietary Information
 © Redfern Integrated Optics (RIO), Inc.
 3350 Scott Blvd, Bldg 62
 Santa Clara, CA 95054 USA

Tel (408) 970 3500
 Fax (408) 970 3200
 sales@rio-inc.com

All preliminary information contained herein is believed to be accurate and is subject to change without notice. No responsibility is assumed for its use. Redfern Integrated Optics, Inc., its subsidiaries and affiliates, or manufacturer, reserve the right to make changes, without notice, to product design, product components, and product manufacturing methods. Some specific combinations of options may not be available. Please contact Redfern Integrated Optics for more information. ©Redfern Integrated Optics, Inc.. All rights reserved.



Parameter	Symbol	Condition	Min	Typ	Max	Unit
Operating temperature range (case)	T_C		-5		+ 75	°C
TEC current	I_{TEC}	$T_{CASE} = 75^{\circ}C, T_S$			1.1	A
TEC voltage	V_{TEC}	$T_{CASE} = 75^{\circ}C, T_S$			3.4	V
Thermistor resistance	R_t	At 25 °C		10		k Ω
Constant of thermistor	β			3950		K
TEC power dissipation	W_0	$T_{CASE} = -5 \text{ to } 75^{\circ}C, T_S$		2.0	3.5	W

Pin-Out

Contact #	Description	Contact	Description
1	Thermistor	8	Not connected
2	Thermistor	9	Package
3	Laser cathode DC Bias Current (-)	10	Package
4	PD Anode (-)	11	Laser Anode (+)
5	PD Cathode (+)	12	Cathode (RF input) [†]
6	TEC +	13	Laser Anode (+)
7	TEC -	14	Package

Mechanical Diagram

Units: mm

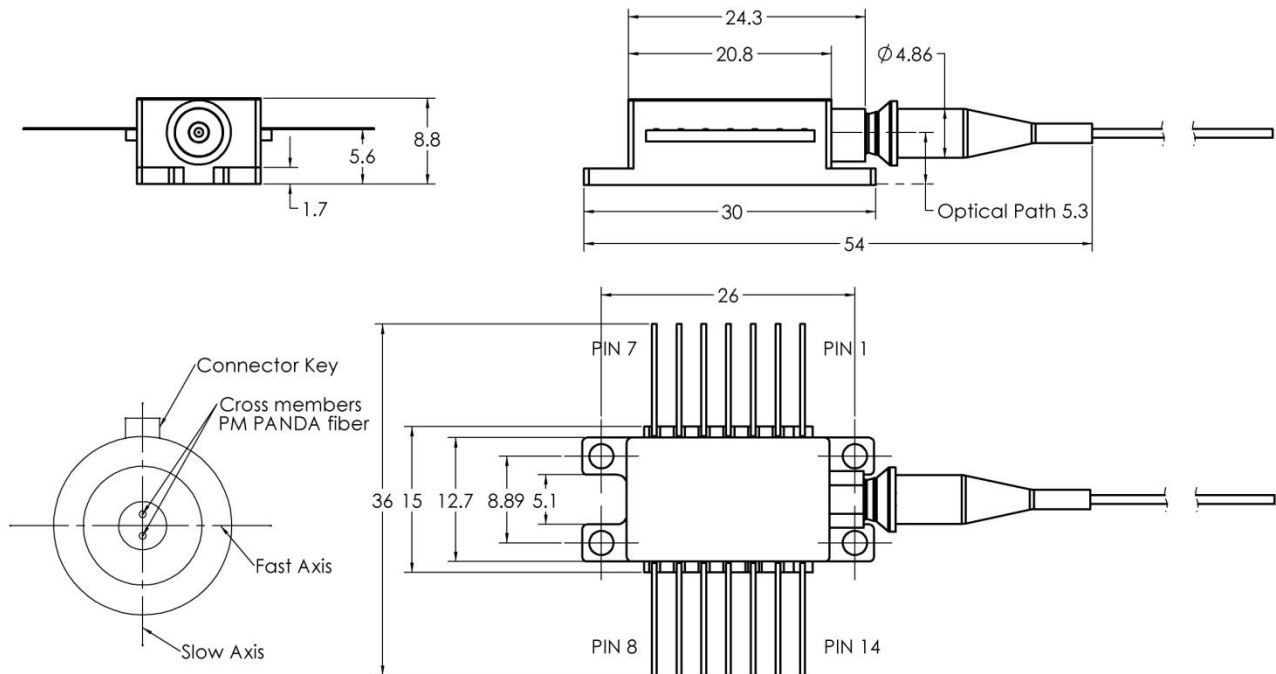

Pigtail options (FC/APC connector):

- SMF 28, 900 μm tight buffer, 1 m
- PMF PANDA, 900 μm loose tube, 1m, key aligned to slow axis

Ordering Information

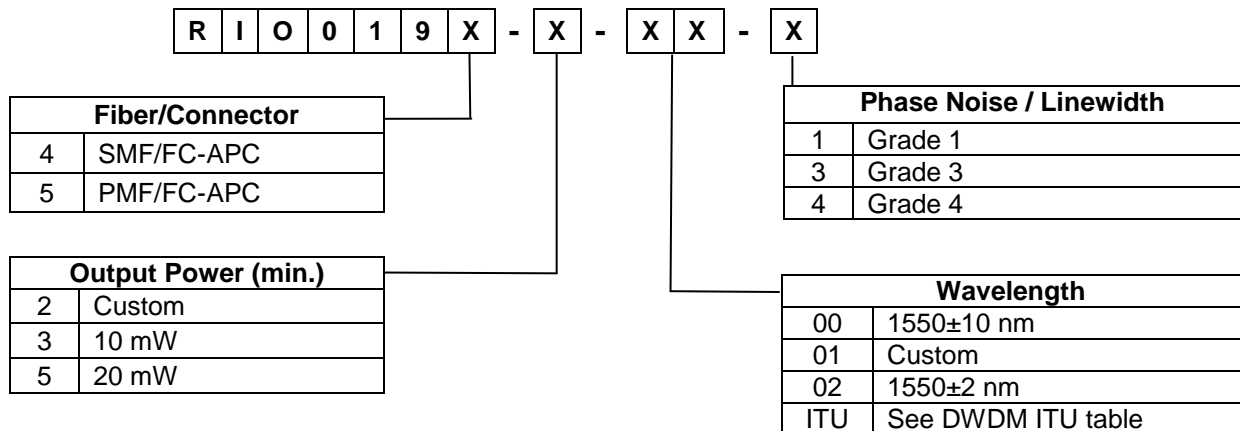

DWDM ITU Wavelength

ITU channel number	ITU Frequency THz	Wavelength nm	ITU channel number	ITU Frequency THz	Wavelength nm	ITU channel number	ITU Frequency THz	Wavelength nm
15	191.50	1565.50	30	193.00	1553.33	45	194.50	1541.35
16	191.60	1564.68	31	193.10	1552.52	46	194.60	1540.56
17	191.70	1563.86	32	193.20	1551.72	47	194.70	1539.77
18	191.80	1563.05	33	193.30	1550.92	48	194.80	1538.98
19	191.90	1562.23	34	193.40	1550.12	49	194.90	1538.19
20	192.00	1561.42	35	193.50	1549.32	50	195.00	1537.40
21	192.10	1560.61	36	193.60	1548.51	51	195.10	1536.61
22	192.20	1559.79	37	193.70	1547.72	52	195.20	1535.82
23	192.30	1558.98	38	193.80	1546.92	53	195.30	1535.04
24	192.40	1558.17	39	193.90	1546.12	54	195.40	1534.25
25	192.50	1557.36	40	194.00	1545.32	55	195.50	1533.47
26	192.60	1556.55	41	194.10	1544.53	56	195.60	1532.68
27	192.70	1555.75	42	194.20	1543.73	57	195.70	1531.90
28	192.80	1554.94	43	194.30	1542.94	58	195.80	1531.12
29	192.90	1554.13	44	194.40	1542.14	59	195.90	1530.33

Laser Safety Information

The PLANEX laser is classified as FDA/CDRH Class IIIb laser products per CDRH, 21 CFR 1040 laser safety requirements.

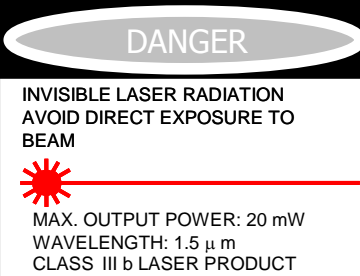
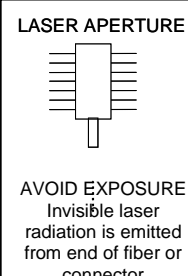
 <p style="text-align: center; font-weight: bold; font-size: 1.2em;">DANGER</p> <p style="text-align: center; font-weight: bold;">INVISIBLE LASER RADIATION AVOID DIRECT EXPOSURE TO BEAM</p> <p style="text-align: center; font-weight: bold;">MAX. OUTPUT POWER: 20 mW WAVELENGTH: 1.5 μm CLASS III b LASER PRODUCT</p>	 <p style="text-align: center; font-weight: bold;">LASER APERTURE</p> <p style="text-align: center; font-weight: bold;">AVOID EXPOSURE Invisible laser radiation is emitted from end of fiber or connector</p>
---	---

Rev.0.2.0

Proprietary Information

© Redfern Integrated Optics (RIO), Inc.
3350 Scott Blvd, Bldg 62
Santa Clara, CA 95054 USA

Tel (408) 970 3500
Fax (408) 970 3200
sales@rio-inc.com

All preliminary information contained herein is believed to be accurate and is subject to change without notice. No responsibility is assumed for its use. Redfern Integrated Optics, Inc., its subsidiaries and affiliates, or manufacturer, reserve the right to make changes, without notice, to product design, product components, and product manufacturing methods. Some specific combinations of options may not be available. Please contact Redfern Integrated Optics for more information. ©Redfern Integrated Optics, Inc.. All rights reserved.

