

plusWAVE2000

Multi-Channel CW Fiber Laser

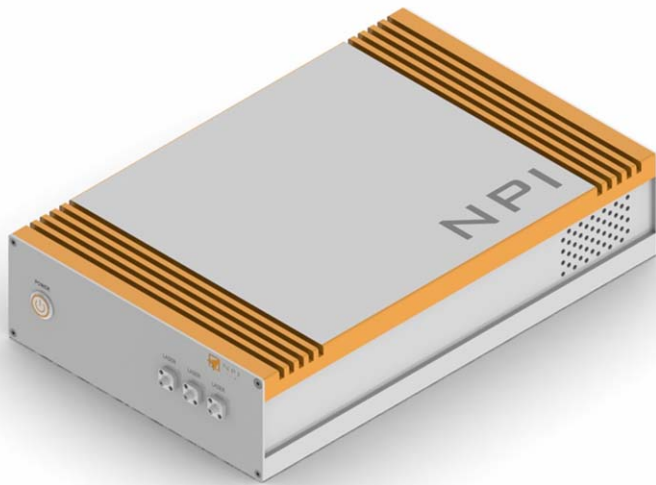

FEATURES

- Customizable wavelengths
- Excellent power stability
- Diffraction limited beam
- Turn-key system
- No maintenance required

NPI's multi-channel CW fiber laser **plusWAVE2000** features multi-wavelength output and excellent output stability, It has many advantages such as compactness, ease of use and low maintenance required.

NPI Lasers is an innovative manufacturer of versatile, reliable and cost-effective fiber laser modules operating in the mid-IR wavelength range. Our team shares a combined optical research/industrial experiences of more than 60 years and this ensures that we understand your specific application needs no matter it is in the field of niche photonics research, industrial sensing and detection, advanced bio-medical procedures, or next-generation laser material processing.

APPLICATIONS

- Gas sensing
- Biomedical analysis
- Spectroscopy
- Test and measurement
- General-purpose light source

SPECIFICATIONS

Parameter	Specification	Parameter	Specification
Operating wavelength	1900-2100 nm selectable (up to 3 ports)	Operating temperature	+10 to +40 °C
Bandwidth	0.8 nm (typical)	Power requirement	AC 100-240 V (50 Hz/60 Hz)
Average Output power	10-100 mW	Power consumption	<20 W
Output power stability	±0.5 % (at +25 °C)	Dimensions	419 mm x 260 mm x 90 mm
Beam quality, M^2	<1.1	Weight	6.0 kg
Output polarization	Random/ Linearly polarized	Connector/fiber type	SM2000 single mode fiber, 1 m pigtail FC/PC or FC/APC connector

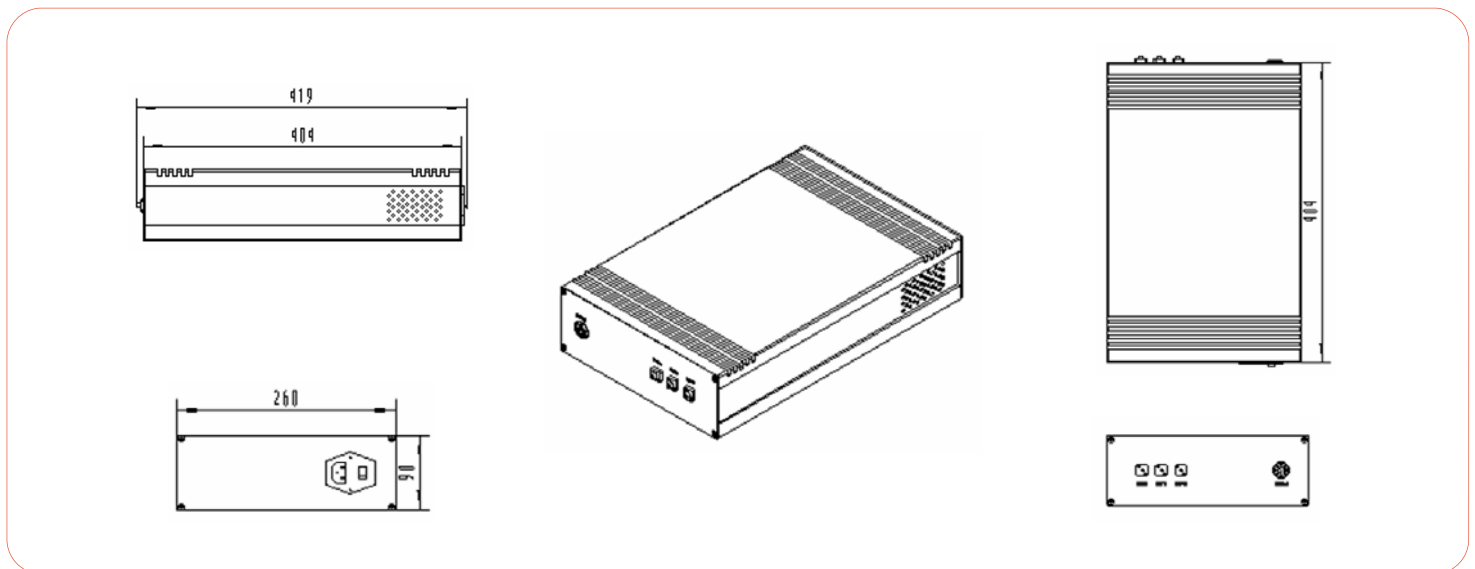

ADDRESS
Floor 4, Cui-Ping Science Park, 37 Jiangjun Avenue,
Jiangning District, Nanjing, 211100, China

CONTACT NUMBER
+86-(0)25-84989433

EMAIL
sales@nplasers.com