



- Adjustable probe holder
- Up to 14 mm/s speed and 15 N thrust
- Plug and play controllers and Joystick included
- 25 mm travel XYZ with resolution finer than 0.05  $\mu\text{m}$
- Programmable or joystick-activated 4th virtual axis to allow approach along probe angle

## Product Description

Zaber's motorized micromanipulator series of products are stand-alone units that are either joystick or computer controlled. They can be mounted to either metric or imperial optical breadboards, and oriented to the left or to the right.

The micromanipulators' probe holders are designed to quickly and easily adjust for probe size and angle. The left thumbscrew on the holder adjusts for the size of the probe (diameters between 2 and 13 mm) and locks it into position. The front face of the holder can be rotated to adjust the angle at which a probe is held, and the top thumbscrew locks it into place.

The X-MCB2 and X-MCB1 controllers connect to the RS-232 or USB port of any computer.

## Dimension Drawings

\*See product page for complete list of available models at [www.zaber.com](http://www.zaber.com)

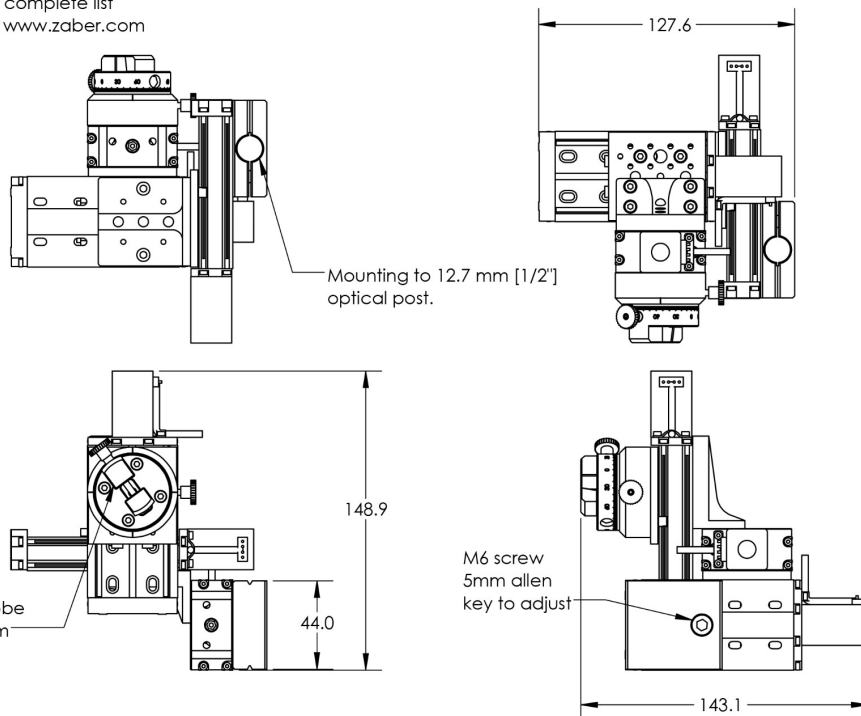

\*See product page for complete list of available models at [www.zaber.com](http://www.zaber.com)

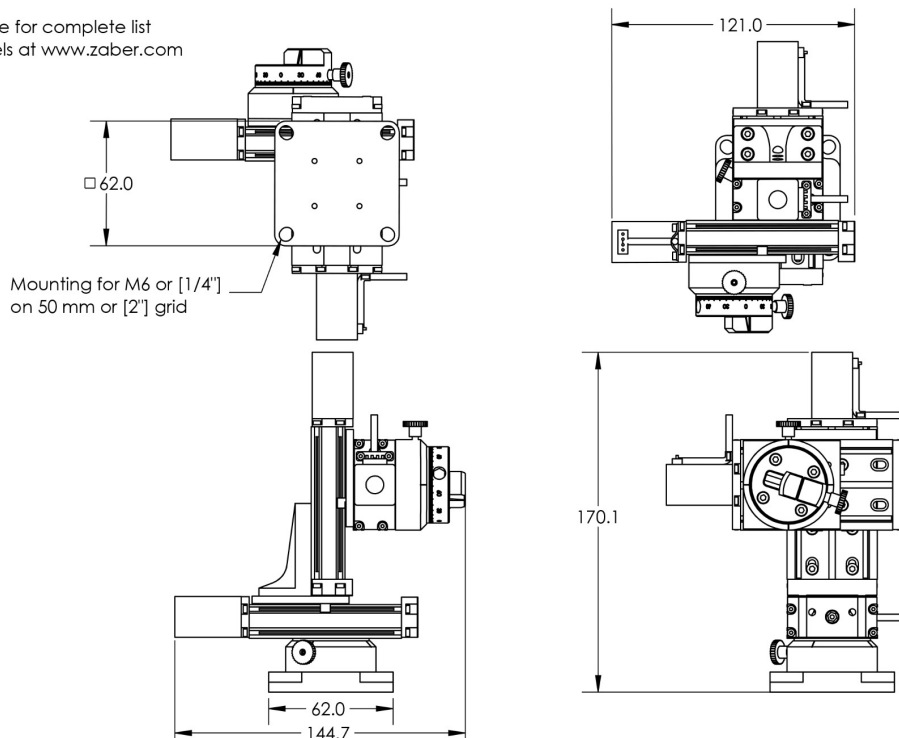

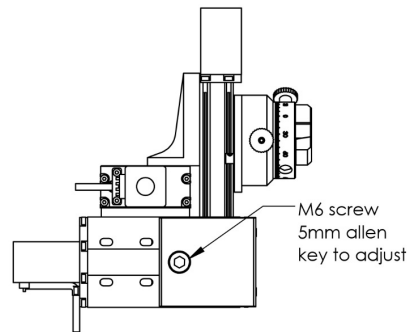
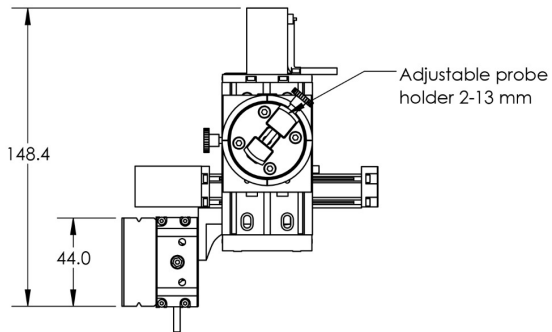
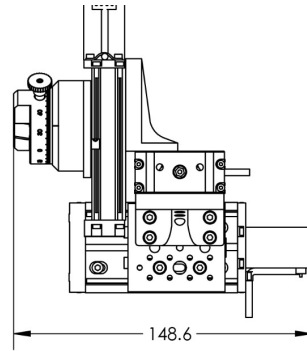
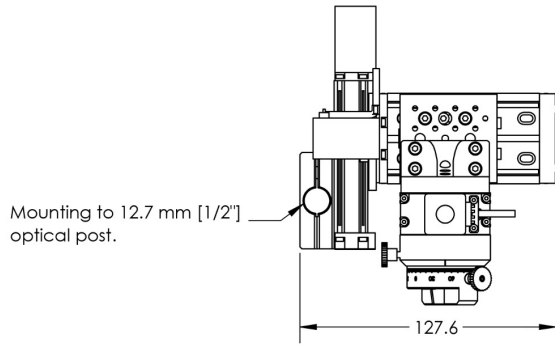

\*See product page for complete list of available models at [www.zaber.com](http://www.zaber.com)

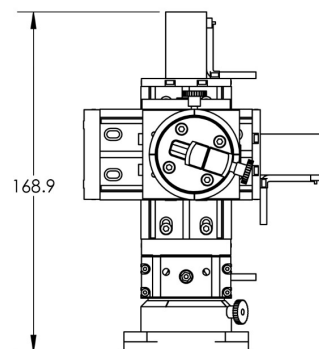
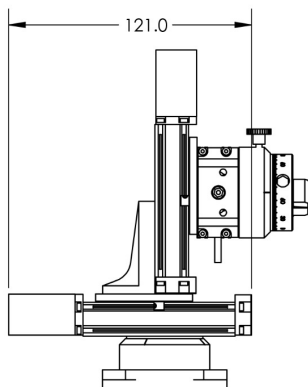
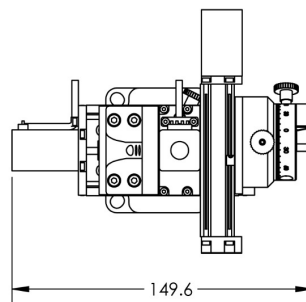
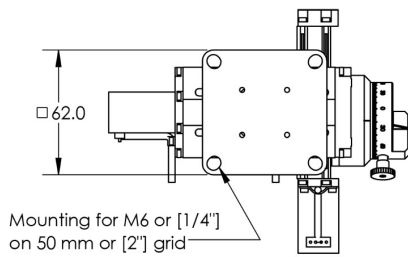

## Product Specifications

Specification	Value	Alternate Unit
Microstep Size (Default Resolution)	0.047625 $\mu\text{m}$	
Recommended Controller	X-MCB2 (24 V) and X-MCB1 (24 V)	
Travel Range	25.4 mm	1.000 "
Accuracy (unidirectional)	8 $\mu\text{m}$	0.000315 "
Repeatability	< 1 $\mu\text{m}$	< 0.000039 "
Backlash	< 3 $\mu\text{m}$	< 0.000118 "
Maximum Speed	14 mm/s	0.551 "/s
Minimum Speed	0.00022 mm/s	0.000009 "/s
Speed Resolution	0.00022 mm/s	0.000009 "/s
Encoder Type	None	
Communication Interface	RS-232	
Communication Protocol	Zaber Binary or Zaber ASCII	
Guide Type	Needle roller bearing	
Vertical Runout	< 8 $\mu\text{m}$	< 0.000315 "
Horizontal Runout	< 12 $\mu\text{m}$	< 0.000472 "
Pitch	0.02°	0.349 mrad
Roll	0.005°	0.087 mrad
Yaw	0.02°	0.349 mrad
Probe Diameter Range	2-13 mm	
Probe Angle Range	360°	6.283 rad
Linear Motion Per Motor Rev	0.6096 mm	0.024 "
Motor Steps Per Rev	200	
Motor Type	Stepper (2 phase)	
Inductance	1.7 mH/phase	
Motor Connection	D-sub 15	
Default Resolution	1/64 of a step	
Mechanical Drive System	Precision lead screw	
Limit or Home Sensing	Magnetic hall sensor	
Axes of Motion	3	
Vacuum Compatible	No	
Operating Temperature Range	0 to 50 °C	
Stage Parallelism	< 25 $\mu\text{m}$	< 0.000984 "

Specification	Value	Alternate Unit
RoHS Compliant	Yes	
CE Compliant	Yes	
Joystick Control	Velocity Mode	
Weight	0.952 kg	2.099 lb

Specification Charts

Thrust Speed Performance

