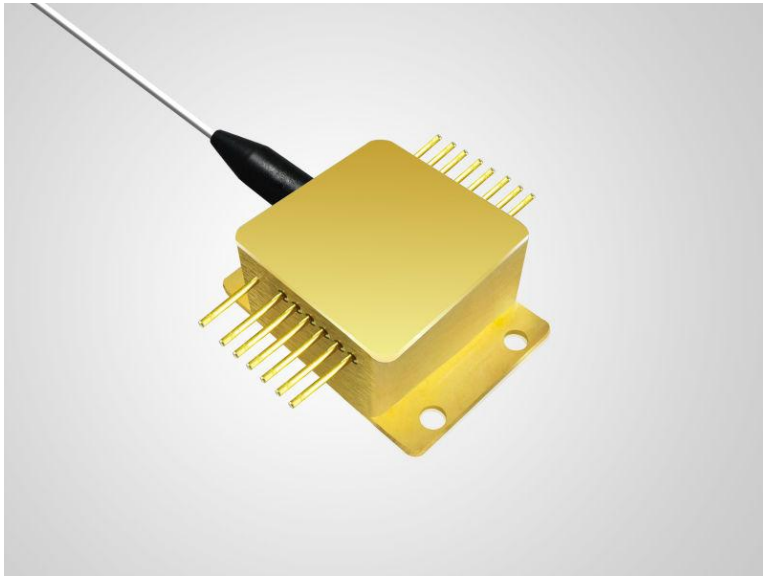

635nm 1.8W Fiber Coupled Diode Laser**K635F15FN-1.800W (Optional Product)****Features:**

- ◆ 635nm wavelength
- ◆ 1.8W output power
- ◆ Standard fiber coupling for 105 μ m core diameter
- ◆ 0.22 NA

Applications:

- ◆ Aiming beam

BWT Beijing's high power diode laser modules are manufactured by adopting specialized fiber-coupling techniques, resulting in volume products with a high efficiency, stability and superior beam quality. The products are achieved by transforming the asymmetric radiation from the laser diode chip into an output fiber with small core diameter by using special micro optics. Inspecting and burn-in procedures in every aspect come to a result to guarantee each product with the reliability, stability and long lifetime.

Our research staffs are constantly improving and innovating the processing technology in the producing process, based on the professional knowledge and experience accumulated in long-terms. We are also continuously developing new products to meet customers' specific needs.

At BWT Beijing, to provide high quality products with reasonable price is our always goal.

635nm 1.8W Fiber Coupled Diode Laser

K635F15FN-1.800W (Optional Product)

Specifications (25°C)		Symbol	Unit	K635EWDRN-5.000W		
				Minimum	Typical	Maximum
Optical Data ⁽¹⁾	CW Output Power	P_o	W	1.8	-	-
	Center wavelength	λ_c	nm	635±5		
	Spectral width(FWHM)	$\Delta\lambda$	nm	-	3	-
	Wavelength Shift with Temperature	$\Delta\lambda/\Delta T$	nm/°C	-	0.3	-
Electrical Data	Electrical-to-Optical Efficiency	PE	%	25	-	-
	Threshold current	I_{th}	mA	-	0.13	-
	Operating current	I_{op}	mA	-	-	0.8
	Operating voltage	V_{op}	V	-	-	30
	Slope Efficiency	η	W/A	-	9	-
Fiber Data	Core diameter	D_{core}	μm	-	105	-
	Cladding diameter	D_{clad}	μm	-	125	-
	Buffer diameter	D_{buf}	μm	-	245	-
	Numeric aperture	NA	-	-	0.22	-
	Fiber length	L_f	m	-	1	-
	Fiber Loose Tubing Diameter	-	μm	0.9mm PVC		
	Minimum Bending Radius	-	mm	60	-	-
Fiber termination	-	-	-	None	-	
PD Data	Current	I_{mo}	μA	50	-	500
Others	ESD	V_{esd}	V	-	-	500
	Storage temperature ⁽²⁾	T_{st}	°C	-20	-	70
	Lead Soldering Temp	T_{is}	°C	-	-	260
	Lead Soldering Time	t	sec	-	-	10
	Operating case temperature ⁽³⁾	T_{op}	°C	15	-	35
	Relative Humidity	RH	%	15	-	75

(1) Data measured under operation output at 1.8W@25°C.

(2) A non-condensing environment is required for operation and storage.

(3) Operating temperature defined by the package case. Acceptable operating range is 15°C~35°C, but performance may vary.

635nm 1.8W Fiber Coupled Diode Laser

K635F15FN-1.800W (Optional Product)

Package Dimensions (mm)

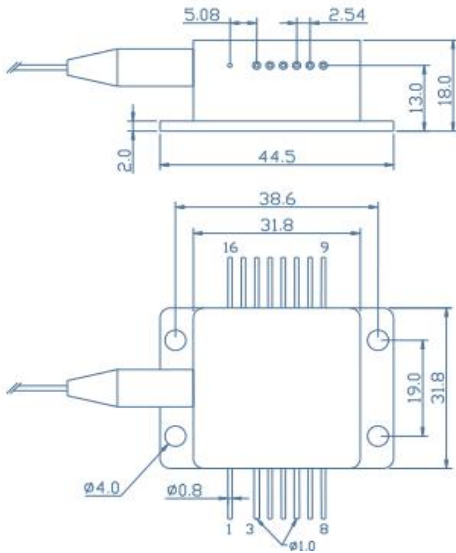

Pins	Function	Pins	Function
1	Case	9	TEC(-)
2	-	10	-
3	LD(+)	11	-
4	Thermistor	12	-
5	Thermistor	13	-
6	LD (-)	14	-
7	PD(P)	15	-
8	PD(N)	16	TEC(+)

OPERATING NOTES

- ◆ Avoid eye and skin exposure to direct radiation during operation.
- ◆ ESD precautions must be taken during storage, transportation and operation.
- ◆ Short-circuit is required between pins during storage and transportation.
- ◆ Please connect pins to wires by solder instead of using socket when operation current is higher than 6A. Soldering point should be close to the root of the pins. Soldering temperature should be lower than 260°C and time shorter than 10 second.
- ◆ Make sure the fiber output end is properly cleaned before operation of laser. Follow safety protocols to avoid injury when handling and cutting the fiber.
- ◆ Use constant current power supply to avoid surge current during operation.
- ◆ Laser diode must be used according to the specifications.
- ◆ Laser diode must work with good cooling.
- ◆ Operation temperature ranges from 15°C to 35°C .
- ◆ Storage temperature ranges from -20°C to +70°C.



Declaration: information and specifications contained herein are deemed to be reliable and accurate. BWT Beijing reserves the right to change, alter or modify the design and specifications of these products at any time without notice.19-1