

Electrically tunable lens EL-12-30-TC

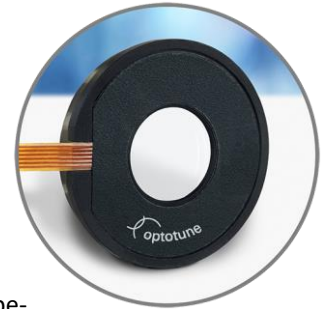

The compact EL-12-30-TC lens is designed for OEM integration into optical systems for various applications. The working principle is based on the well-established shape-changing lens technology. The curvature of the lens is adjusted by applying an electrical current. Thereby, the focal length is tuned to a desired value within a few milliseconds. The lens architecture is “push pull” which means that the lens curvature is deflected from concave to convex. With actuators based on proven voice-coil technology, the EL-12-30-TC focus tunable lens is extremely reliable and robust, well suited even for applications in harsh environments over large temperature ranges.

Lens specifications

Clear aperture	11.6	mm
Focal power range: (25°C, ±250 mA)	-6 to +10	dpt
Focal power @ 0 mA (25°C, typical)	-1 to +2	dpt
Wavefront error @ 0 dpt (Optical axis vertical / horizontal)	0.15 / 0.23	λ RMS @ 532 nm
Lens type	plano-concave to plano-convex	
Refractive index / Abbe number	$n_D = 1.45 / v = 55$	
Response time (typ. at 25°C, 0 to ±250 mA step)	3	ms
Settling time (typ. at 25°C, 0 to ±250 mA step, ±0.1 dpt)	10 (with signal conditioning) 20 (rectangular step)	ms
Lifecycles (10% - 90% sinusoidal)	> 1'000'000'000	
Operating temperature	-20 to 65	°C
Storage temperature	-40 to 85	°C
Weight	10.5	g

Electrical specifications

Nominal control current	-250 to 250	mA
Motor coil resistance @ 25°C	15	Ω
Power consumption for 5 dpt range (±60mA)	55	mW
Max power consumption (@ 250 mA)	940	mW
Memory	ON Semiconductor: CAT24C64C4CTR (or similar)	
Temperature sensor	Maxim Integrated: MAX31875R2TZS+T (or similar)	
Absolute maximum voltage (coil)	6	V
Absolute maximum voltage (memory & sensor)	4	V

Mechanical Layout

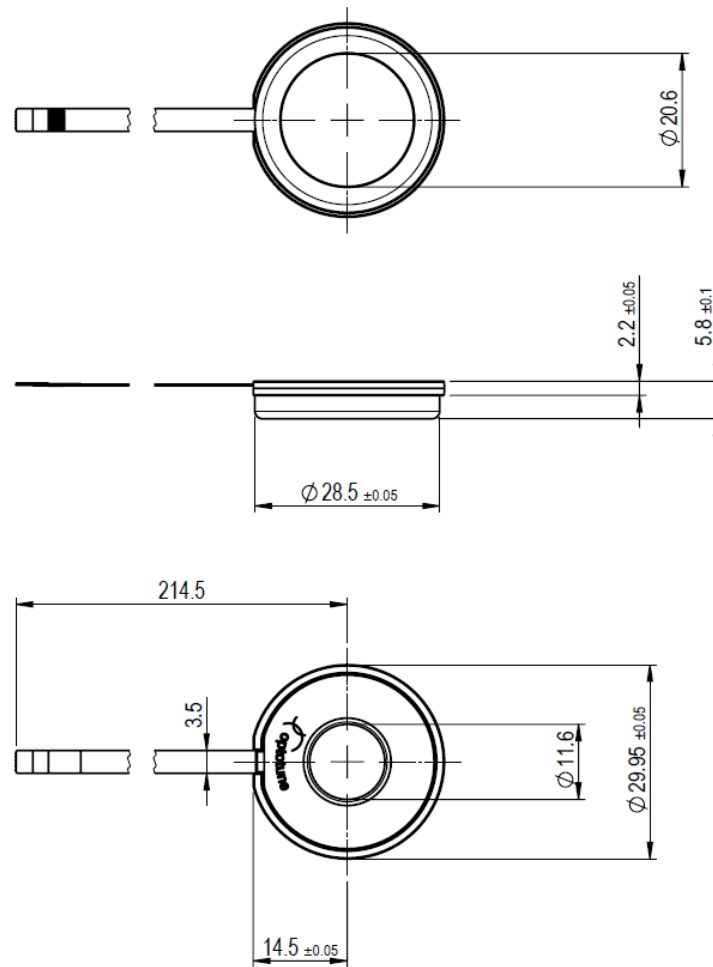

Figure 1: Mechanical drawing of the EL-12-30-TC

Optical Layout

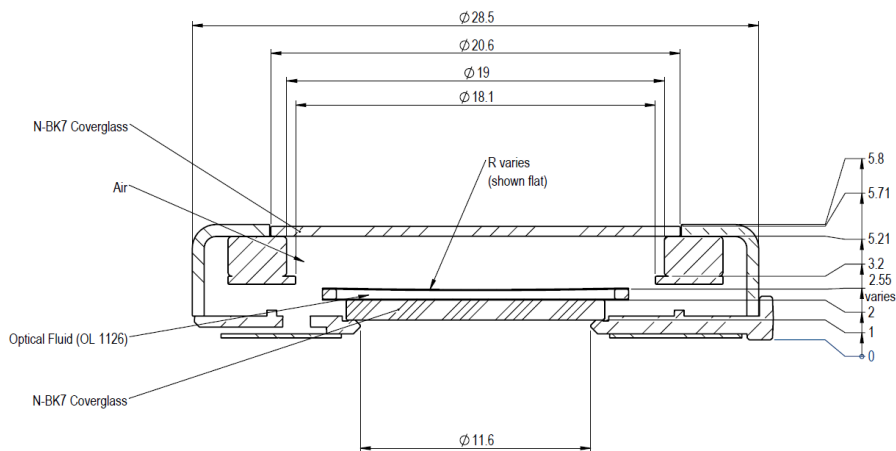

Figure 2: Optical Layout of the EL-12-30-TC

Electrical connection

The electrical connection of the EL-12-30-TC without adapters consists of a FPC flex cable with 6 pins suitable for Molex connector no. 503480-0600 or equivalent. Two pins are for the coil of the lens, the other four pins are for the I²C connection to the temperature sensor and EEPROM.

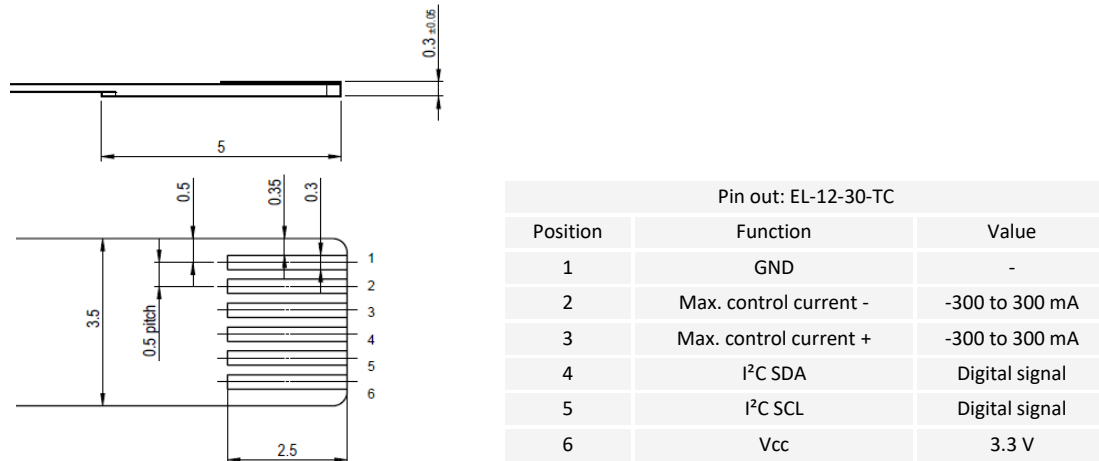

Figure 3: Electrical flex connections of the EL-12-30-TC

Component:	Temperature Sensor	EEPROM
I ² C Address	Maxim Integrated: MAX31875R2TZS+T	ON Semiconductor: CAT24C64C4CTR
BIN	0b 1001 010x	0b 1010 000x
HEX	W: 0x94; R: 0x95	W: 0xA0; R: 0xA1
DEC	W: 148; R: 149	W: 160; R: 161

Figure 4: Electrical components and addresses

Liquid lens working principle

The working principle of the EL-12-30-TC is based on Optotune's well-established technology of shape-changing polymer lenses. The core that forms the lens contains an optical fluid, which is sealed off with an elastic polymer membrane as shown in Figure 5. An electromagnetic actuator is used to exert pressure on the container and therefore changes the curvature of the lens. By changing the electrical current flowing through the coil of the actuator, the focal power of the lens is controlled.

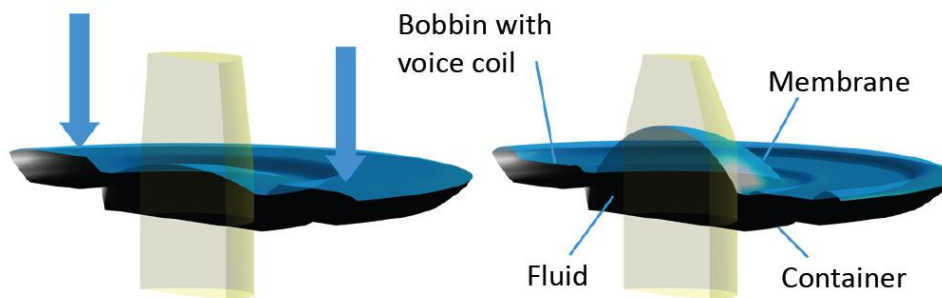

Figure 5: Working principle of the sealed lens container filled with an optical fluid and embedded in an EL-12-30-TC housing.

Focal power versus current

The focal power of the EL-12-30-TC increases with positive and decreases with negative current as shown in Figure 6. When driving the lens up to absolute maximum control current, the tuning range increases further but significant heat generation must be considered.

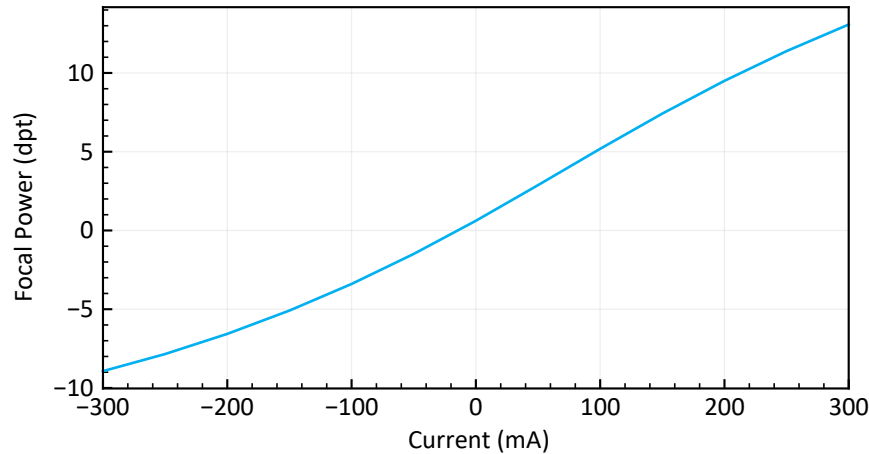

Figure 6: Typical data showing the relation between focal power (in diopters) and electrical current

Transmission

Both the optical fluid and the membrane material are highly transparent in the range of 400 to 2500 nm. As the membrane is elastic it cannot be coated using standard processes, hence a reflection of 3 – 4% is to be expected. Cover glasses can be coated as desired. Figure 7 shows the transmission spectrum for the standard broad-band coating.

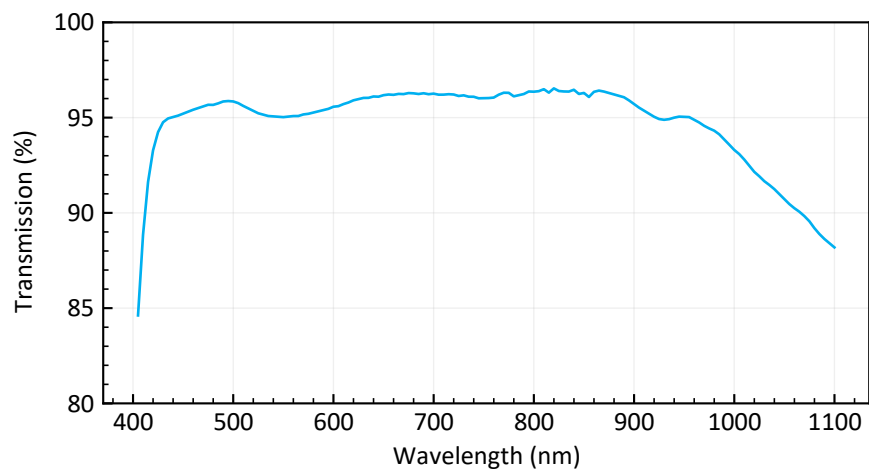

Figure 7: Transmission spectrum of standard EL-12-30-TC.

Wavefront Error

Figure 8 shows the typical wavefront error as a function of Focal power. The wavefront quality varies from lens to lens and can be specified differently upon request. Best wavefront performance is typically achieved between 0 and 5 diopters. When using the lens standing upright (optical axis horizontal) a Y-coma term must be added resulting in a wavefront error in the order of $0.2-0.25 \lambda$ RMS. The gravity induced Y-coma term depends on the clear aperture of the lens, the density of the liquid, the mechanical properties of the membrane and can be optimized upon request.

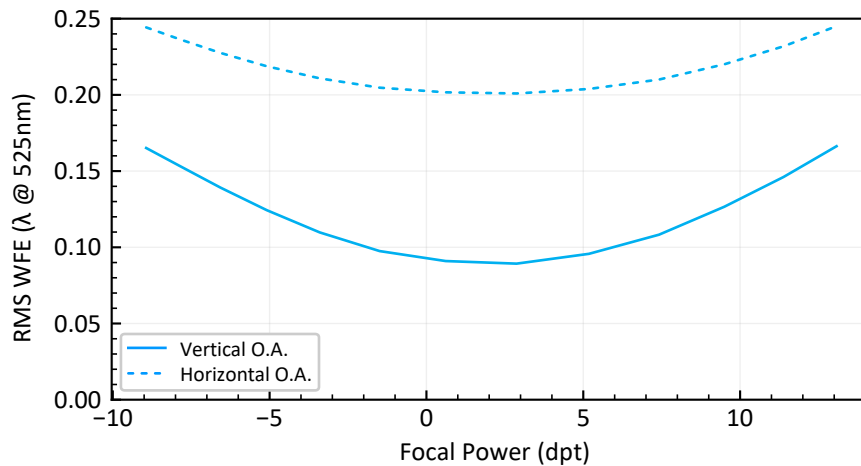

Figure 8: Typical wavefront error of the EL-12-30-TC vs focal power with optical axis vertical and horizontal (@525nm, measured over 80% of the clear aperture).

Response time

The EL-12-30-TC exhibits a very fast response time of about 3 ms and a settling time of about 20 ms based on a rectangular step, which can be improved to about 10 ms with signal conditioning implemented in Optotune's controllers.

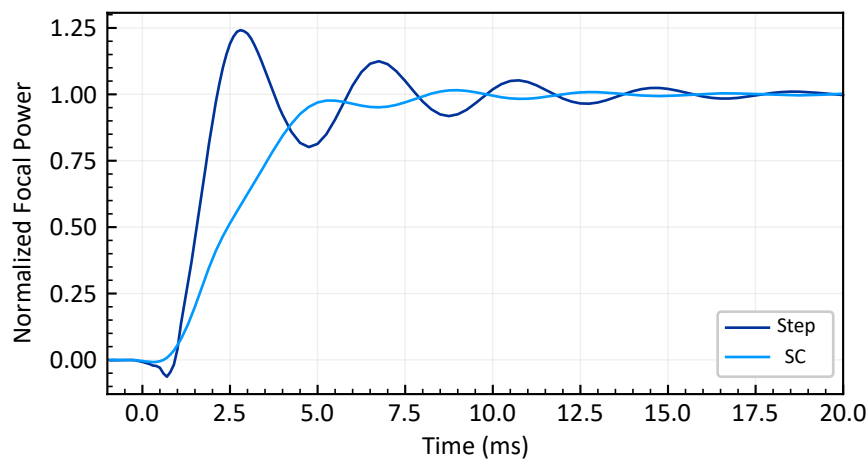

Figure 9: The settling time can be improved with signal conditioning (SC)

Figure 10 shows the focal power response for several current steps measured at room temperature.

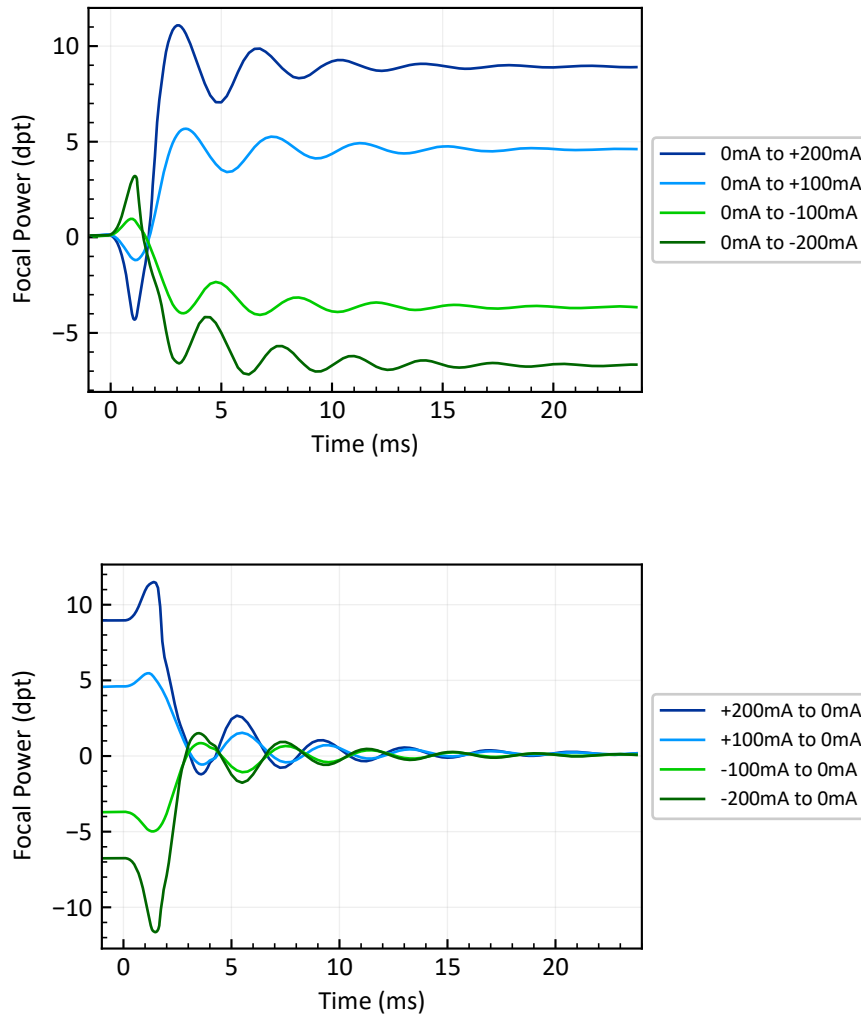

Figure 10: Typical focal power response of the EL-12-30-TC. The upper plot shows a series of steps from low to high current and the lower plot for steps from high to low current.

Temperature effects

Residual temperature effects influence the long-term drift of focal power stated in the specification table. These temperature effects are quantified by the temperature sensitivity S (dpt/°C), giving the change in focal power per degree Celsius. As shown in Figure 11, there is an almost linear dependence of S with focal power. Generally, temperature effects can be minimized when the EL-12-30-TC is thermally connected to a heat sink. The mounting itself can be used as a heat sink. Large mass and high thermal conductivity of the material dissipates the heat more efficiently.

Best thermal performance is achieved when operating the EL-12-30-TC in the range of 0 to 5 diopters.

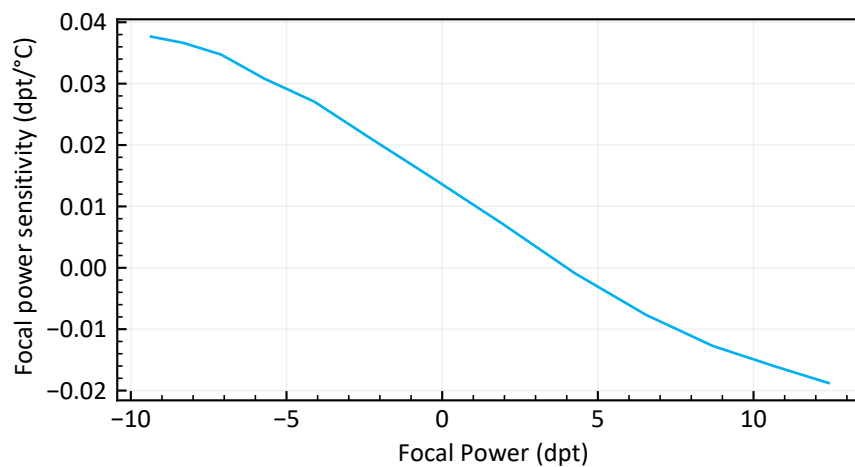

Figure 11: Temperature sensitivity as a function of focal power.

Autofluorescence, birefringence & polarization effects

The EL-12-30-TC is neither auto-fluorescent, birefringent or in any other way polarization dependent.

Safety and compliance

The product fulfills the RoHS and REACH compliance standards. The customer is solely responsible to comply with all relevant safety regulations for integration and operation.

For more information on optical, mechanical, and electrical parameters, please contact sales@optotune.com