

# BLADE™ RF

NEVER ENDING POWER LASERS



Mid Power CO<sub>2</sub> LASERS  
Power from 350W to 850W

- Semisealed Technology: no factory refilling needed
- Radio Frequency excited
- Low operative cost & Easy integration
- High reliability & High beam quality
- Same size for all powers
- High electrical/optical conversion efficiency
- Integrated RF power supply
- TCP/IP connection for remote diagnostics and control

# BLADE™ RF

## NEVER ENDING POWER LASERS

With more than three decades experience in CO<sub>2</sub> laser sources manufacturing, EL.EN. has installed worldwide over 2500 industrial solutions.

The **BLADE RF SEMISEALED** technology provides an unsurpassed stability of the laser power, allowing absolute consistency of the processes parameters in the long term operations. The internal gas cartridge is extremely easy to change (typically twice a year) at extraordinary low cost. The **BLADE RF SEMISEALED** laser is the first laser that joins the advantages of the RF excitation technology (high peak power, high frequency modulation, compactness) with the incredible advantages of virtually “no factory service” requirement of the self refilling solution.

### MAIN APPLICATIONS

- High performance galvo scanners applications
- Plastics, wood and leather cutting
- Digital converting
- Polypropylene coating & film cutting
- Labels kiss-cutting

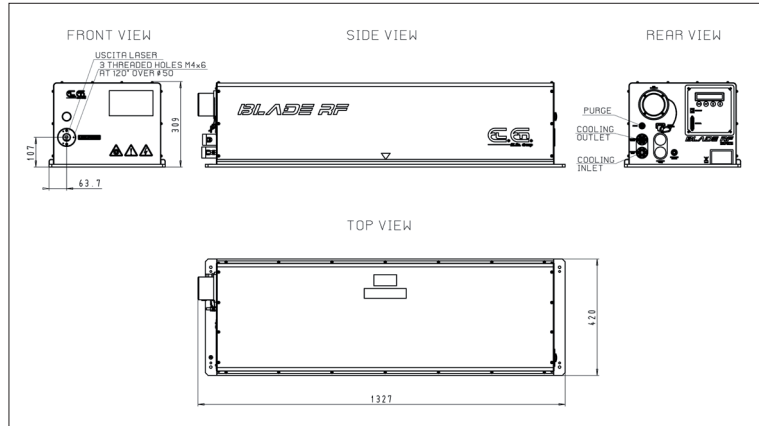
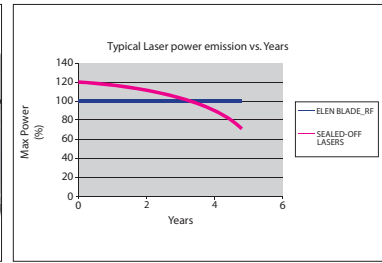

### Systems Specifications

Model	RF 333	RF 333P <sup>(1)</sup>	RF 555	RF 777	RF 888
Rated power (W)	350	330	550	750	850
Effective peak power (W)	>850	>750	>1650	>1750	1800
Power stability (long term)	±4%	±5%	±5%	±5%	±5%
Wavelength (μm)	10.6 ± 0.4	10.2 ± 0.2	10.6 ± 0.4	10.6 ± 0.4	10.6 ± 0.4
Polarization	Linear horizontal	Linear horizontal	Linear vertical	Linear vertical	Linear vertical
Beam diameter (1/e <sup>2</sup> at the exit) (mm)	9.2 ± 0.5	9.2 ± 0.5	11.8 ± 0.5	11.8 ± 0.5	11.8 ± 0.5
Beam divergence (full angle) (mrad)	2.0 ± 0.2	2.0 ± 0.2	1.0 ± 0.1	1.0 ± 0.1	1.0 ± 0.1
Maximum pulsing frequency (kHz)	100	100	100	100	100
Pulse width range (μs)	2 ÷ 1000	2 ÷ 150	2 ÷ 150	2 ÷ 150	2 ÷ 150
Mode quality (M <sup>2</sup> )	<1.1	<1.1	<1.2	<1.2	<1.2
Beam ellipticity	1.1:1	1.1:1	1.2:1	1.2:1	1.2:1
Typical gas mix consumption (Cartridge/year)	2	2	2	2	3
Pulse Rise /Fall Time (μs)	< 50	< 50	< 50	< 50	< 50
Environmental temperature range (°C)	5° ÷ 35°	5° ÷ 35°	5° ÷ 35°	5° ÷ 35°	5° ÷ 35°
Maximum humidity	Non condensing at inlet water cooling temperature				

### Electrical Power Requirements

Input voltage (V <sub>DC</sub> )	48 ± 1	48 ± 1	48 ± 0.5	48 ± 0.5	48 ± 0.5
Max current (A)	100	100	140	180	200

### Coolant

Heat dissipation (W)	5000	5000	6800	9000	10000
Coolant temperature (°C)	20° ± 1°	20° ± 1°	20° ± 1°	20° ± 1°	20° ± 1°
Max water cooling input pressure (bar)	4	4	5	5	5
Water cooling flow rate (l/min)	11±1	11±1	15±1	17±1	19±1

### Dimensions/Weight

Dimensions (LxWxH) (mm)	1327x420x309				
RF Power supply dimensions	Integrated				
Weight (kg)	92	92	110	110	110

1 - Selected wavelength for polypropylene processing

NOTE: Aiming to product improvement EL.EN. SpA reserves the right to change specifications without notice. Purchaser acknowledges that the products must comply with applicable regulations before they can be resold to customers. EL.EN. lasers are produced under a quality assurance system certified according to ISO 9001.



EL.EN. S.p.A.  
Via Baldanzese, 17 - 50041 CALENZANO (FI) - ITALY  
Tel. +39/055/8826807 - Fax +39/055/8832884  
www.elenlaser.com - www.elengroup.com  
industrialdivision@elengroup.com

