

Full-HD 20x Optical Zoom Module Technical Manual

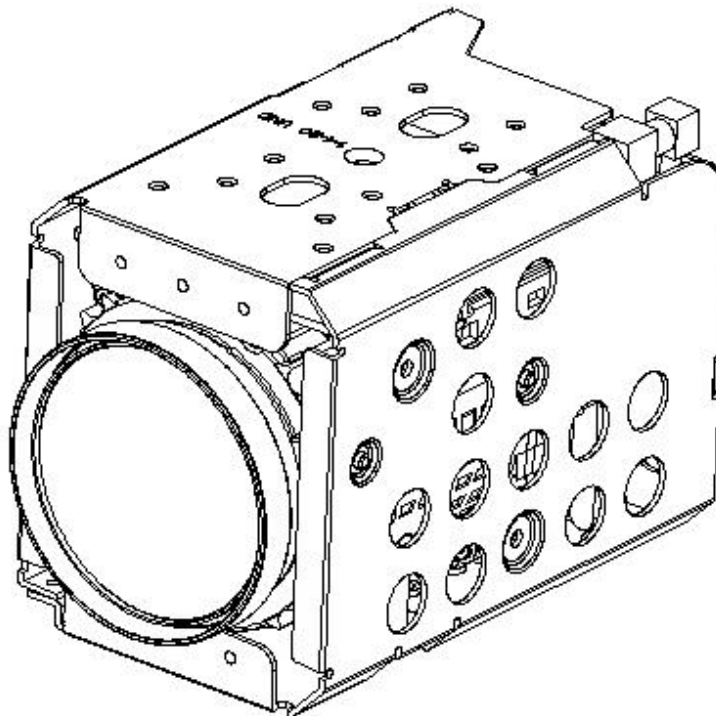

DATE : 2017-03-27

VERSION : 2.03

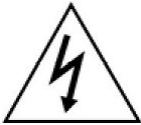

Revision History

Version	Date	Description	Remarks
1.00	2014-02-21	First Release	
1.01	2014-11-15	Revise Application Circuit	
1.02	2015-05-18	Add Visca command list	
2.00	2015-09-07	Revise Application Circuit, Menu Tree	

	CAUTION	
RISK OF ELECTRIC SHOCK DO NOT OPEN		
CAUTION : TO REDUCE THE RISK OF ELECTRIC SHOCK, DO NOT REMOVE COVER. ACCESSORIES SOLD SEPARATELY. CONTACT QUALIFIED SERVICE PERSONNEL FOR INFORMATION ACCESSIBLE ACCESSORIES.		

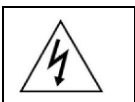

The lightning arrowhead symbol in a triangle means to watch out for live wires that might cause an electrical shock.



The exclamation symbol in a triangle indicates an important operational and service instruction.

WARNING

Please note that the user is liable for any incidents in operating the unit if it is altered or modified without manufacturer’s approval.

CAUTION

To prevent electric shock and risk of fire hazards:
Do not use power sources except for that specified.
Do not expose this appliance to rain or moisture.

This installation should be made by a qualified service person and should abide to all local codes.

INDEX

- 1. SAFETY INSTRUCTIONS4
- 2. PRECAUTIONS5
- 3. FEATURES6
- 4. SPECIFICATION7
- 5. COMMUNICATION PROTOCOL8
- 6. OPERATING CAMERA9
 - 6.1. Camera OSD menu9
 - 6.2. WHITE BALANCE..... 11
 - 6.3. EXPOSURE..... 11
 - 6.4. FOCUS..... 12
 - 6.5. BACK LIGHT 12
 - 6.6. IMAGE CONTROL 13
 - 6.7. DISPLAY CONTROL 14
 - 6.8. RESET 14
- 7. Video Output 15
 - 7.1. Video Mode..... 15
 - 7.2. Output Timing Chart(1920x1080p@30/60)..... 16
 - 7.3. Output Timing Chart(1920x1080p@25/50)..... 17
 - 7.4. Output Timing Chart(1920x1080i@60)..... 18
 - 7.5. Output Timing Chart(1920x1080i@50)..... 19
 - 7.6. Output Timing Chart(1280x720p@60)..... 20
 - 7.7. Output Timing Chart(1280x720p@50)..... 21
 - 7.8. Video Data Start/Stop Format..... 22
- 8. Camera Interface..... 23
 - 8.1. Camera Interface..... 23
 - 8.2. LVDS Interface 24
 - 8.3. Key Application recommended circuit..... 28
 - 8.4. Application of recommended circuit Camera Reception 28
- 9. Dimensions..... 32
- APPENDIX A..... 33

1. SAFETY INSTRUCTIONS

Read Instructions

Read all of the safety and operating instructions before using the product.

Retain Instructions

Save this instructions for later use.

Cleaning

Unplug this appliance form wall outlet before cleaning. Do not use liquid cleaners or aerosol cleaners. Use a damp cloth for cleaning.

Water and Moisture.

Do not use this product near water or moisture.(For example. Near a bathtub, wash bowl, kitchen sink, or laundry tub, in a wet basement, or near swimming pool, etc.)

Installation

Do not place this product on an unstable cart, stand, or table. The product may fall causing serious injury to a child or adult, and damage to the product.

Use only with a cart or stand recommended by the manufacturer, or sold with the product. Mounting should follow the manufacturer's instructions, and should use a mounting accessory recommended by manufacturer.

Power source

This Product should be operated only form the type of power source indicated on marking label.

If you are not sure of the type of power supplied to your home, consult your dealer or local power company.

2. PRECAUTIONS

- **Do not use the camera in extreme temperature conditions.**

Please use the camera within -10°C to 50 °C

Air vent is required at high temperature

- **Do not use or store the camera in humid environment**

It may cause poor image quality.

- **Do not use the camera in unstable lighting conditions.**

Inconsistent lighting or flickering may cause poor image.

- **Never use the camera close to gas or oil leak.**

It may not operate properly.

- **Do not disassemble the camera.**

There is no user serviceable part inside.

- **Do not drop the camera or apply force on it.**

It may cause a malfunction.

- **Never face the camera to strong light for long periods of time.**

It may damage the CMOS sensor.

- **Do not expose the camera to rain or any types of liquid**

If wet, wipe the moisture out immediately.

Liquids can contain minerals that corrode the electronic components.



When this camera is installed near wireless communication devices that emits strong electromagnetic field, irregularity such as noise may appear in the image.

3. FEATURES

- 1/3 inch CMOS image sensor (approx. 2.1 million effective pixels)
 - Progressive scan
- WDR (Wide Dynamic Range) Function
- Video signals output
 - HD LVDS : Digital ITU-R BT.1120 - YcbCr4:2:2 16bits, 20bits(single LVDS mode)
 - HD SDI(optional):
 - SMPTE 292M(1.485Gbps) 1920x1080p@25,30 1920x1080i@50,60 1280x720p@25,30,50,60
 - SMPTE 424M(2.97Gbps) 1920x1080p@50,60
- 20x optical zoom lens with F1.6 aperture(optical zoom + digital zoom = 240x)
- Day and Night
 - ICR for infrared cut filter
- Privacy Zone Masking function
- Communications protocol supported to be controlled remotely
 - SONY-VISCA, PELCO-P/D, etc
- High performance functions
 - 3D-DNR (Digital Noise Reduction)
 - BLC (Back Light Compensation)
 - Motion Detection
 - DIS (Digital Image stabilizer)
 - DSS (Digital Slow Shutter)
 - Image flip
 - HLC (High Light Compensation)

4. SPECIFICATION

		SPECIFICATIONS
Sensor	Image Sensor	1/3" Progressive CMOS (Approx. 2.1 mega)
	Scanning System	16:9 Progressive
	Sync. System	Internal
	Effective Pixel	1920(H) x 1080(V)
	Min. Illumination	0.2Lux (Day), 0.1Lux (Night), 0.005Lux(DSS on)
	Horizontal Resolution	1000TVL
Optics	Lens	20x optical Zoom, F=4.7~94mm, F1.6 ~ F3.5
	Zoom	20x optical zoom + 12x digital zoom = 240x
	Focus	Near/Far, Auto/Manual/One Push
	Angle of View(H)	57.4 degrees(WIDE), 3.2 degrees(TELE)
Functions	Back Light Compensation	WDR/BLC, HLC(High Light compensation)
	Exposure	Auto / Manual
	White Balance	Auto(3,000°K~8,000°K) / ATW(1,900°K~11,000°K) / Manual
	Day & Night System	AGC / TDN(ICR)
	Electronic Shutter	NTSC: 1/30~1/30000, PAL: 1/25~1/30000, DSS(~ 1/1sec)
	Functions	Privacy Mask, Image Mirror, 3DNR, Flicker-less, Sharpness, Defog, DIS(Digital Image stabilizer), NegArt, Freeze
Video Outputs	Digital Output (LVDS)	1920x1080p@25,30,50,60 1920x1080i@50,60 1280x720p@25,30,50,60 ITU-R BT.1120 YcbCr4:2:2 16bits, 20bits(single LVDS mode)
	SDI Output (optional)	SMPTE 292M(1.485Gbps): 1080p@25,30 1080i@50,60 720p@25,30,50,60 SMPTE 424M(2.97Gbps): 1080p@50,60 800mVp-p, 75Ω, unbalanced generator(single-ended)
	Control Interface	UART(5V level) PELCO-P/D, SONY-VISCA protocol 8bits data, 1 stop bit, no parity, 2400~115200bps
	General	Operation Temperature: -20℃ ~ 60℃ Power Input: 12VDC (7V to 15VDC) Power consumption: Max 5W (3.2W Lens inactive, 3.9W Lens active) Mass: Approx. 240g (8.5 oz.) Dimensions: 87(D) x 50(W) X 60(H) mm

5. COMMUNICATION PROTOCOL

PELCO "D" Byte Format

Command Message

Command	Data						
	BYTE 1	BYTE 2	BYTE 3	BYTE 4	BYTE 5	BYTE 6	BYTE 7
Zoom Tele	0xFF	CamID	0x00	0x20	0x00	0x00	Checksum
Zoom Wide	0xFF	CamID	0x00	0x40	0x00	0x00	Checksum
Focus Near	0xFF	CamID	0x01	0x00	0x00	0x00	Checksum
Focus Far	0xFF	CamID	0x00	0x80	0x00	0x00	Checksum
Up(Menu)	0xFF	CamID	0x00	0x08	0x00	0x00	Checksum
Down(Menu)	0xFF	CamID	0x00	0x10	0x00	0x00	Checksum
Left(Menu)	0xFF	CamID	0x00	0x04	0x00	0x00	Checksum
Right(Menu)	0xFF	CamID	0x00	0x02	0x00	0x00	Checksum
Menu On/Off	0xFF	CamID	0x40	0x00	0x00	0x00	Checksum
STOP	0xFF	CamID	0x00	0x00	****	****	Checksum

Pelco Keyboard (95+PATTERN)

Function	Menu On / Off						
	BYTE 1	BYTE 2	BYTE 3	BYTE 4	BYTE 5	BYTE 6	BYTE 7
MSG	0xFF	CamID	0x00	0x23	0x00	0x5F	Checksum

V/D Keyboard (Set Preset +98)

Function	Menu On / Off						
	BYTE 1	BYTE 2	BYTE 3	BYTE 4	BYTE 5	BYTE 6	BYTE 7
MSG	0xFF	CamID	0x00	0x03	0x00	0x62	Checksum

6. OPERATING CAMERA

6.1. Camera OSD menu

WB CONTROL	AWB			
	ATW			
	PUSH			
	INDOOR			
	OUTDOOR			
	MANUAL	RED	0 ~ 31	
	BLUE	0 ~ 31		
AE CONTROL	MODE	AUTO/MANUAL/SHUTTER PRI/IRIS PRI/BRIGHT		
	BRIGHTNESS	0 ~ 20		
	IRIS	AUTO		
		MANUAL	0 ~ 17	
	AGC LIMIT	0 ~ 20		
	SHUTTER	AUTO		
		MANUAL	1/30/60/90/100/125/180/250/350/500/725/1000/1500/2K/3K/4K/6K/10K/20K/30K/40K	
DSS	OFF/ ~ 1/1			
FLICKERLESS	OFF/ON			
FOCUS CONTROL	FOCUS MODE	AUTO/MANUAL/ONE PUSH		
	ZOOM SPEED	0 ~ 7		
	TELE LIMIT	~Optical(X20), ~Digital Zoom(X240)		
	WIDE LIMIT	X1 ~X19		
	FAR END	2M/3M/5M/10M/INFINITY		
	NEAR END	30CM/1M/1.5M/2M/3M/5M/10M		
	LENS INITIAL	OFF/PUSH/AUTO		
	USER PRESET	PRESET	0 ~ 31	
		ACTIVE		
SAVE				
BACK LIGHT	WDR/BLC	OFF		
		WDR	WDR-LEVEL 0~4	
		BLC		
		SPOT	WIDTH	
		HEIGHT		
		MOVE HOR		
		MOVE VER		
	ACE	GAIN	LOW/MIDDLE/HIGH	
	ECLIPSE	LEVEL	0~20	
		COLOR	BLK/BLU/RED/MAG/GRN/CYN/YEL/WHT	
IMAGE CONTROL	DAY/NIGHT	AUTO	D/N LEVEL 0 ~ 20	
			MARGIN 0 ~ 20	
			DWELL TIME 1 ~ 20	
			NIGHT BURST OFF/ON	

		DAY			
		NIGHT	NIGHT BURST OFF/ON		
		EXT	LEVEL/DWELL TIME/NIGHT BURST		
	COLOR LEVEL	0 ~ 20			
	SHARPNESS	0 ~ 20			
	IMAGE FLIP	OFF/MIRROR-HOR/FLIP-VER/ROTATION			
	DEFOG	MODE	AUTO/MANUAL		
		GAIN	LOW/MIDDLE/HIGH		
	3D-DNR	OFF/LOW/MIDDLE/HIGH			
	MOTION	DET.SIZE	0 ~ 4		
		SENSITIVITY	0 ~ 20		
		MASK ACTIVE	OFF/ON		
		WIDTH			
		HEIGHT			
		MOVE HOR			
		MOVE VER			
	IMAGE STABILIZER	RANGE	10%/20%/30%		
		FILTER	LOW/MIDDLE/HIGH		
		AUTO CENTER	HALF/FULL		
	SHADING	OFF/ON			
	GAMMA	STANDARD/STRAIGHT/LOW/MIDDLE/HIGH			
	RESOLUTION	HD1080P25/PAL, HD1080P30/NTSC, HD1080i50/PAL, HD1080i60/NTSC, HD720P50/PAL, HD720P60/NTSC, HD1080P50/PAL, HD1080P60/NTSC, HD720P25/PAL, HD720P30/NTSC,			
	DISPLAY CONTROL	USER TITLE	OFF/ON		
		ZOOM MAG	OFF/ON		
		PRIVACY	MASK NO	1~8	
			MASK ACTIVE	OFF/ON	
MASK COLOR			BLK/BLU/RED/MAG/GRN/CYN/YEL/WHT		
WIDTH					
HEIGHT					
MOVE HOR					
MOVE VER					
TRANS			0~4		
ADDRESS		1 ~ 255			
ADR DISPLAY		OFF/ON			
BAUDRATE		2400/4800/9600/19200/38400/57600/115200			
LANGUAGE		ENGLISH/简体/FRANÇAIS/DEUTSCH/ESPAÑOL/PORTUGUÊS/РУССКИЙ			
DEFECT ADJ		OFF/ON			
VER.					
RESET					
EXIT	SAVE/ NOT SAVE				

6.2. WHITE BALANCE

AWB : Color temperature is automatically adjusted to 3,000°K ~ 8,000°K

ATW : Color temperature is automatically adjusted to 1,900°K ~ 11,000°K

INDOOR : Color temperature is manually adjusted to indoor

OUTDOOR : Color temperature is manually adjusted to outdoor

MANUAL WB : Color Temperature is manually adjustable to adjusting value.

RED and BLUE gain can be changed for better pictures.

PUSH WB : Color Temperature is manually adjustable to adjusting value.

The One Push White Balance mode is a fixed white balance mode that may be automatically readjusted only at One Push Trigger, while the camera is directed at a piece of white paper to obtain the optimum state under current illumination.

One Push White Balance data is lost when the power is turned off. If the power is turned off, reset One Push White Balance.

6.3. EXPOSURE

MODE :

AUTO – Iris, gain and shutter can be controlled automatically.

MANUAL – Manual control of Iris, gain and shutter.

SHUTTER Priority – Manual control of shutter. Iris and gain can be controlled automatically.

IRIS Priority - Manual control of IRIS. Shutter and gain can be controlled automatically.

BRIGHT – Iris and gain can be controlled by control of brightness

BRIGHTNESS :

The bright control function adjusts gain and iris, to keep a brightness level.

IRIS :

Auto - Iris controls exposure automatically, and shutter is fixed.

Manual - Iris is fixed, and gives the exposure control priority to other resources.

AGC : To select maximum automatic gain limit.

Camera raises up gain to selected gain limit when dark conditions.

SHUTTER :

Auto – Shutter controls exposure automatically when iris is manual.

Manual - Shutter is fixed, and gives the exposure control priority to other resources.

DSS :

Minimum slow shutter limit is down to 1/1 second.

The value means seconds.

Camera make Shutter speed longer to selected shutter limit when dark conditions.

FLICKERLESS :

This function used only for specific country to remove light flickering when light appears to flutter.

6.4. FOCUS

The camera employs a 20x optical zoom lens combined with a 12x digital zoom function. This camera allows you to zoom up to 240x.

Optical 20x, f = 4.7 mm to 94 mm (F 1.6 to F 3.5)

Digital Zoom 12x : enlarges of the subject

7 levels of zoom speed

FOCUS MODE :

Auto mode automatically adjusts the focus position.

Manual mode adjusts the focus position by manual and when zoom is changed.

One Push mode - When One Push AF command is sent, camera becomes Auto Focus mode to adjust focus position for a while. After it stops, mode becomes that for Manual focus mode.

LENS INITIAL : This function repeats adjustment the focus position at the interval.

FOCUS NEAR END : Near limit for the focusing range.

FOCUS FAR END : Priority for focusing distance. The lens moves to adjust the focus from the distance.

USER PRESET : This function is able to move quicker zoom and focus positions. 32 presets can be set.

6.5. BACK LIGHT

BLC : When background is too bright behind the object, the BLC make clearer object.

WDR : When background is too bright behind the object, the WDR make clearer images of the background as well as the object. Wide dynamic range produce images that combining long-exposure signals (normal shutter) with the signals of the high-intensity portions obtained with a short exposure (high-speed shutter).

ACE : Dark areas of image brightness correction

ECLIPSE : Highlight suppression reduce too bright light by masking it with specific color.

6.6. IMAGE CONTROL

DAY / NIGHT

- **AUTO** : Auto day/night mode automatically switches between Color and Black/White depending on darkness. ICR(IR cut) filter is removed when it switches to black/white.
D/N level – This level is threshold for switching day to night. It is same as the exposure gain level.
Margin – Different exposure gain level is needed to avoid malfunctions.
Dwell time - is checking time for condition of light to confirm changing to Color and Black/White.
Night Burst – Night burst off makes that the color burst is removed when ICR switches to black/white.
- **DAY** : The camera keeps color mode constantly.
- **NIGHT** : The camera keeps black/white mode constantly.
- **EXT** : External control trigger input may switch between Day and Night mode.
Connect D/N input pin to GND to activate night mode or leave floating to deactivate.

COLOR LEVEL

Color level is the colorfulness of a color relative to its own brightness.

SHARPNESS

As you increase this value, the picture outline becomes stronger and clearer. Adjust this value appropriately depending on the sharpness of the picture.

IMAGE FLIP

Video output is set horizontally vertically, and rotate.

DEFOG

This function affects the effect of fog removal. Furthermore it improves visibility by removing fog, clouds, smoke, and dust.

3D-DNR

3DNR reduces video noises at low ambient light.

MOTION

Video zone settings and sensitivity can be set.

IMAGE STABILIZER

This function reduces image blurring associated with the motion of a camera.

SHADING

Image center and the outskirts of brightness difference correction

GAMMA

Video out brightness correction function

RESOLUTION

Video output specification set(NTSC/PAL) and video size settings(1080p/720p)

6.7. DISPLAY CONTROL

USER TITLE

OSD character camera name settings..

ZOOM MAGNIFICATION

Display the Zoom scale.

PRIVACY

It is possible to set the size of the area and a video Mask.

ADDRESS

The camera is capable of recognizing number setting up 0 to 255.

BAUDRATE

Camera communication bit rate.

LANGUAGE

Camera OSD Character selection and display.

6.8. RESET

Camera returns into initial value except ID and baudrate.

7. Video Output

7.1. Video Mode

Video output :

1080p - 2200x1125@30/60fps, 2640x1125@25/50fps

1080i - 2200x562(563)@60fps, 2640x562(563)@50fps

720p - 1650x750@60fps, 1980x750@50fps, 3300x750@30fps, 3960x750@25fps

Pixel clock : 74.25MHz, 148.5MHz

YCbCr422 16bits data(BT.1120 format), HD, VD

YCbCr422 20bits data(BT.1120 format) only for single LVDS output mode

Active area (1920 x 1080)

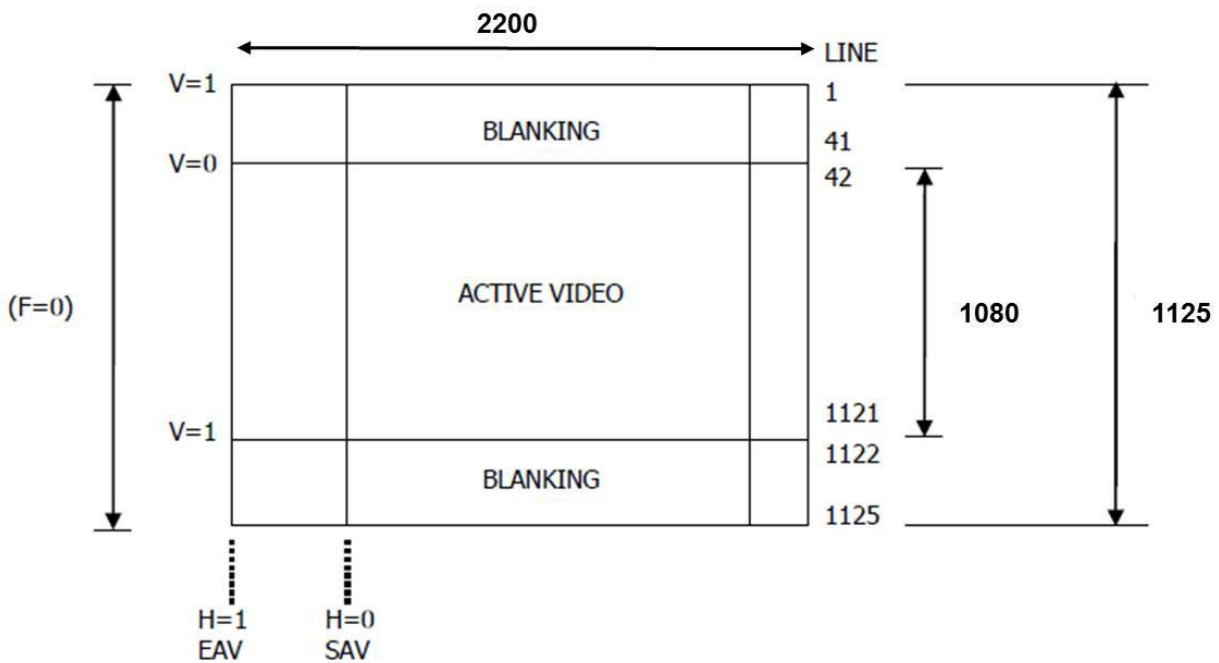

7.2. Output Timing Chart(1920x1080p@30/60)

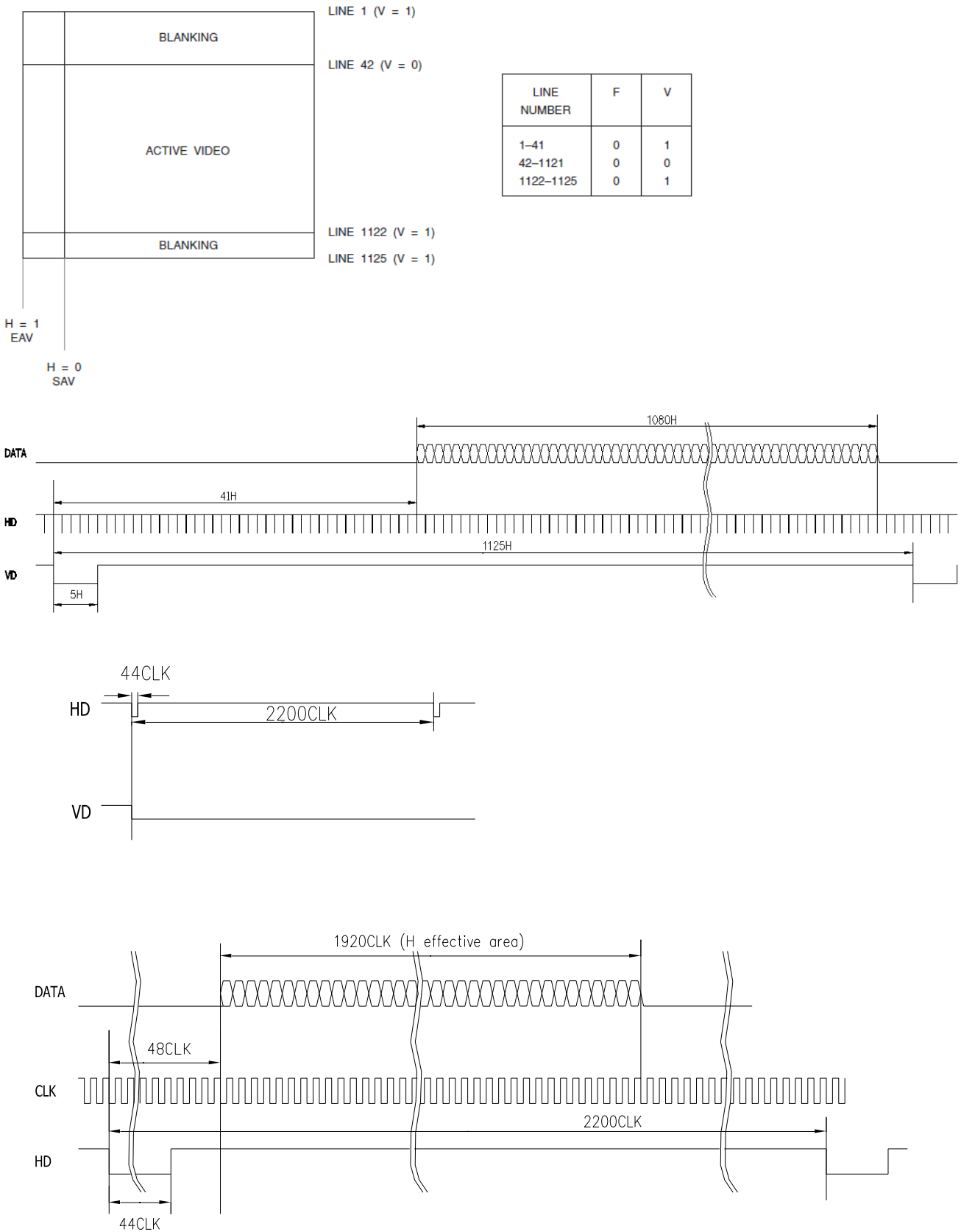

7.3. Output Timing Chart(1920x1080p@25/50)

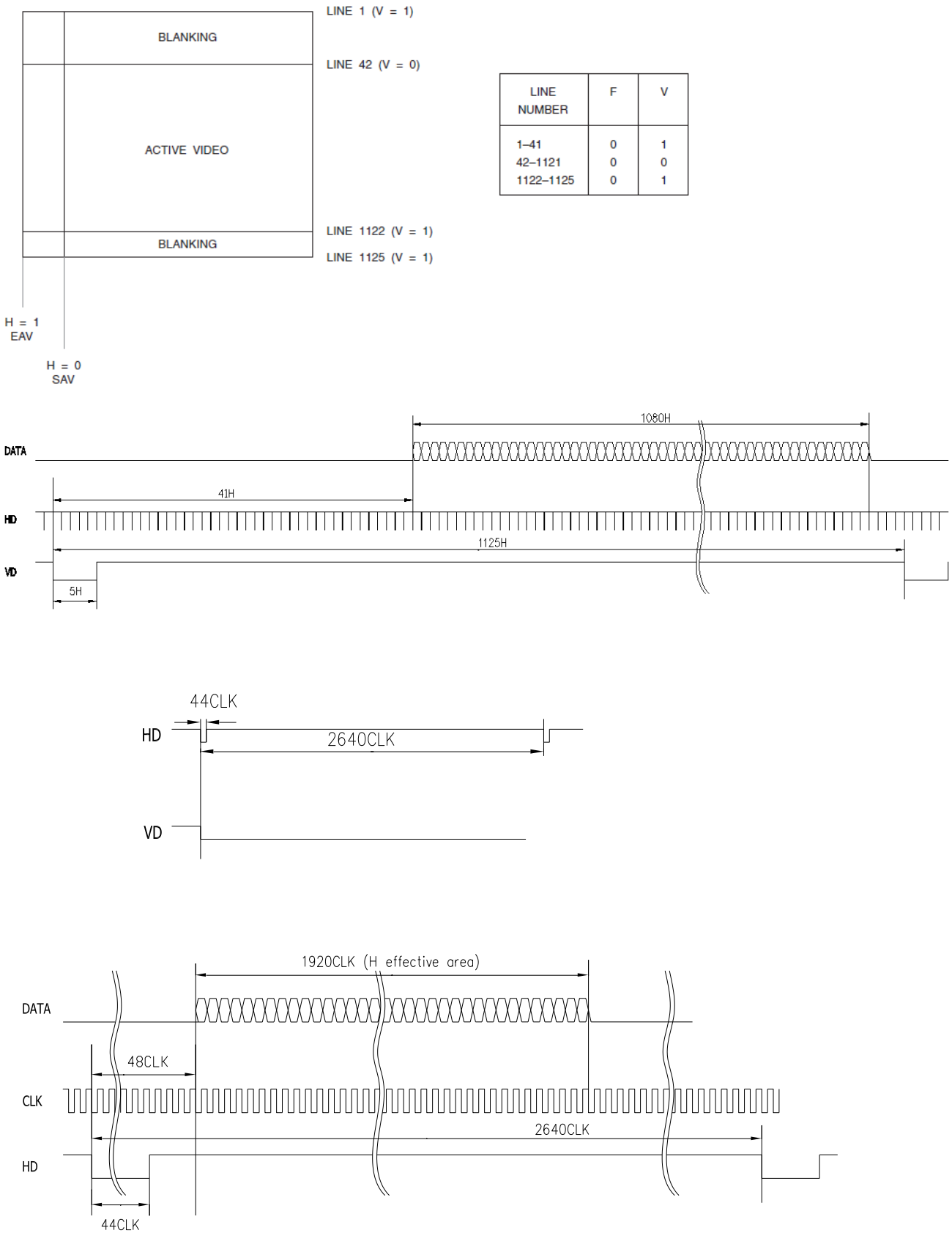

7.4. Output Timing Chart(1920x1080i@60)

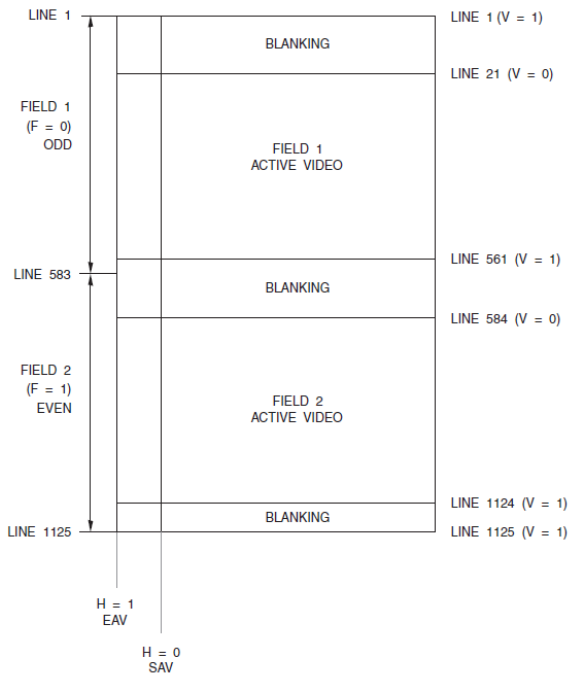

LINE NUMBER	F	V
1-20	0	1
21-560	0	0
561-562	0	1
563-583	1	1
584-1123	1	0
1124-1125	1	1

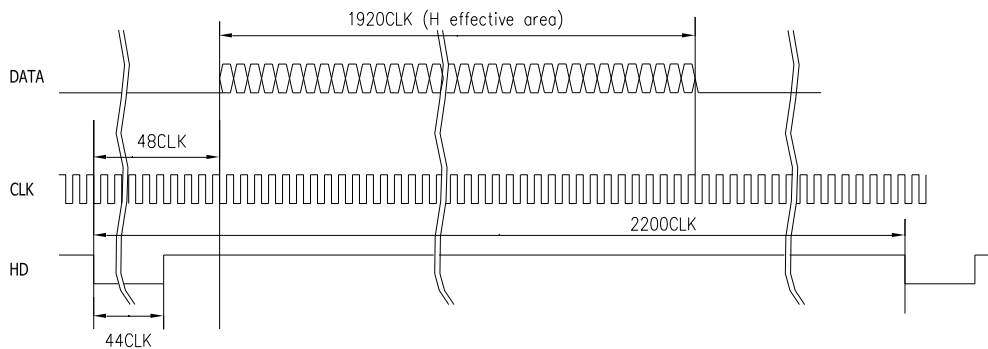
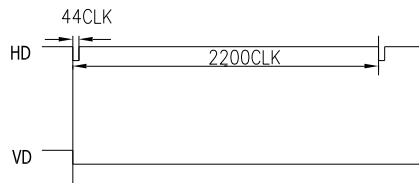
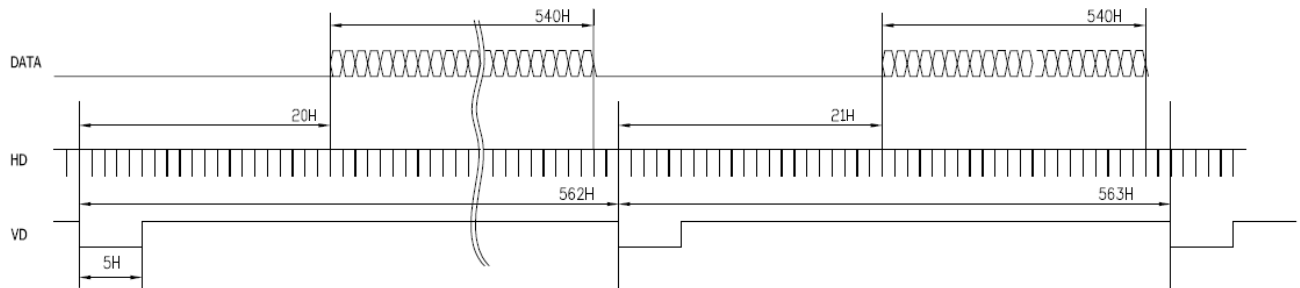

7.5. Output Timing Chart(1920x1080i@50)

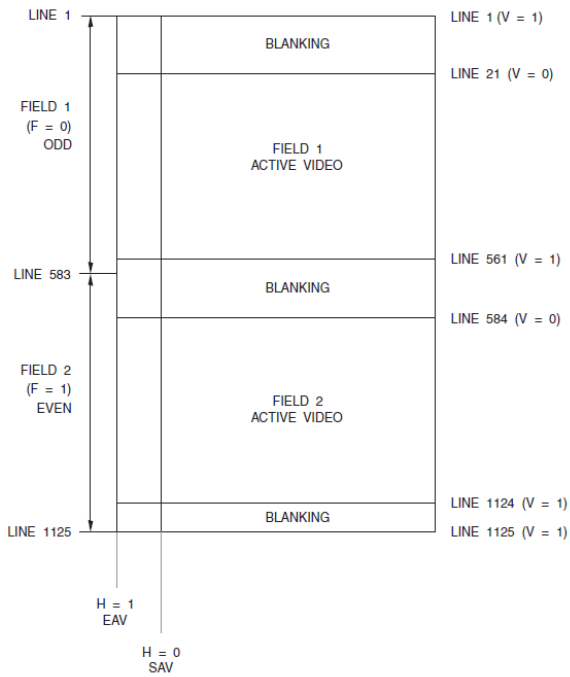

LINE NUMBER	F	V
1-20	0	1
21-560	0	0
561-562	0	1
563-583	1	1
584-1123	1	0
1124-1125	1	1

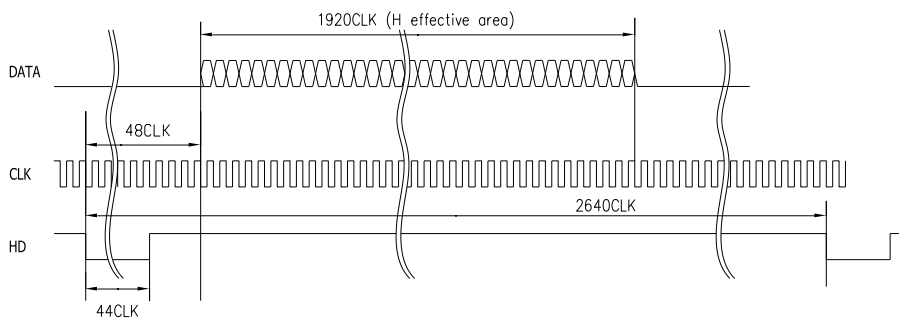
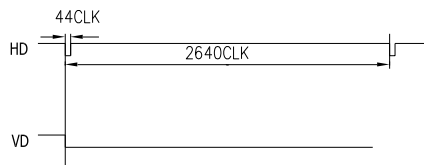
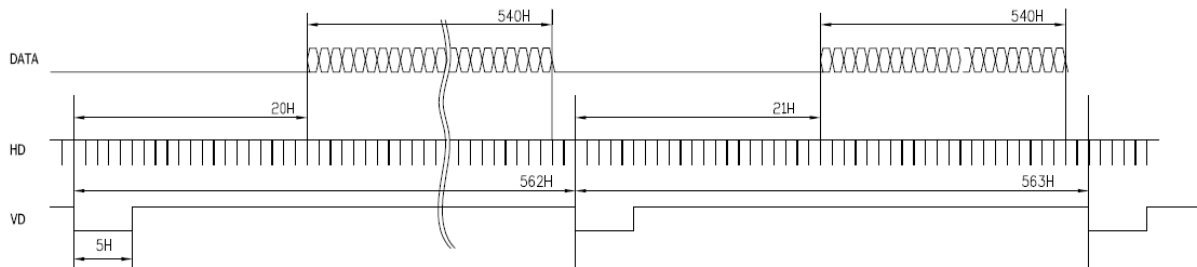

7.6. Output Timing Chart(1280x720p@60)

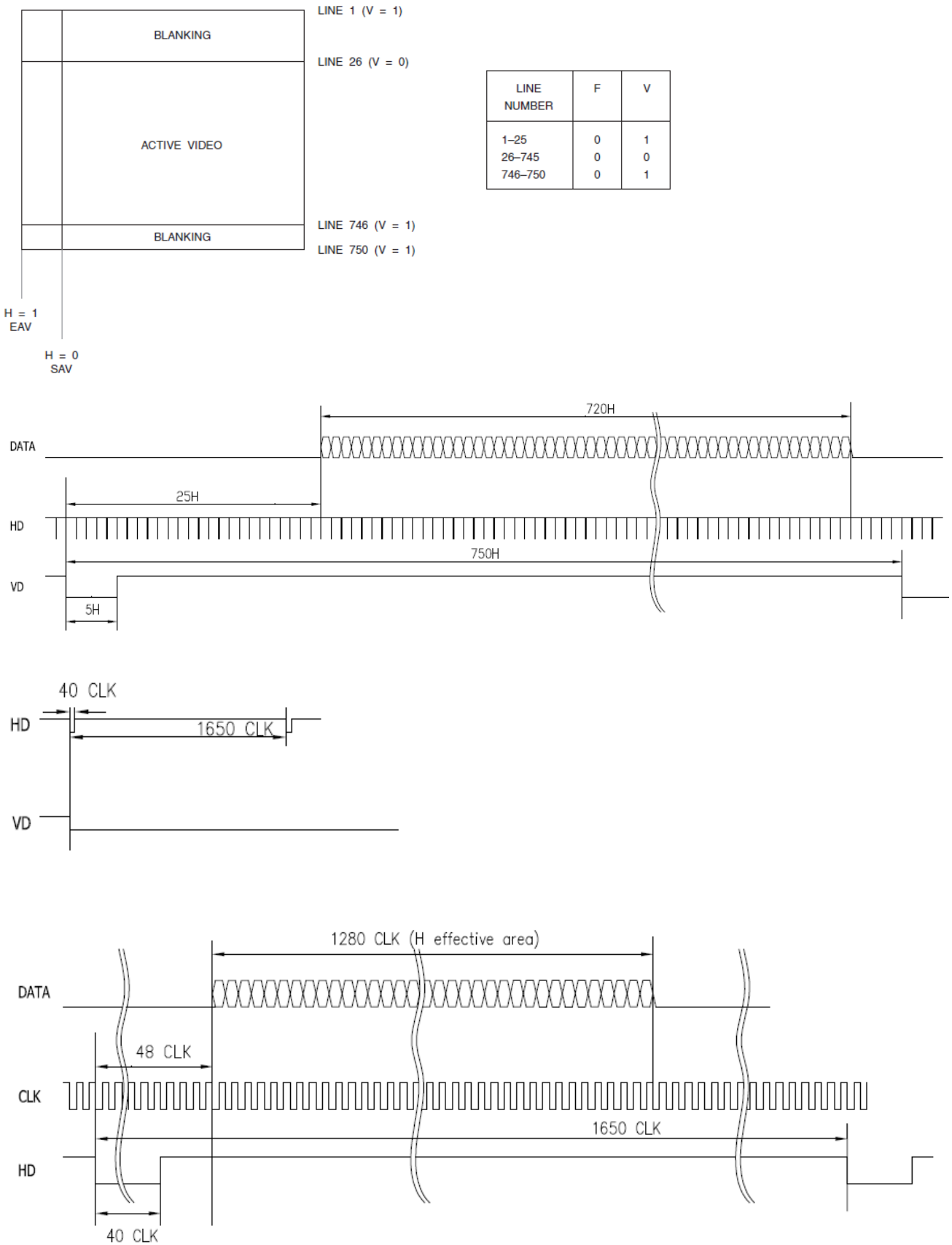

7.7. Output Timing Chart(1280x720p@50)

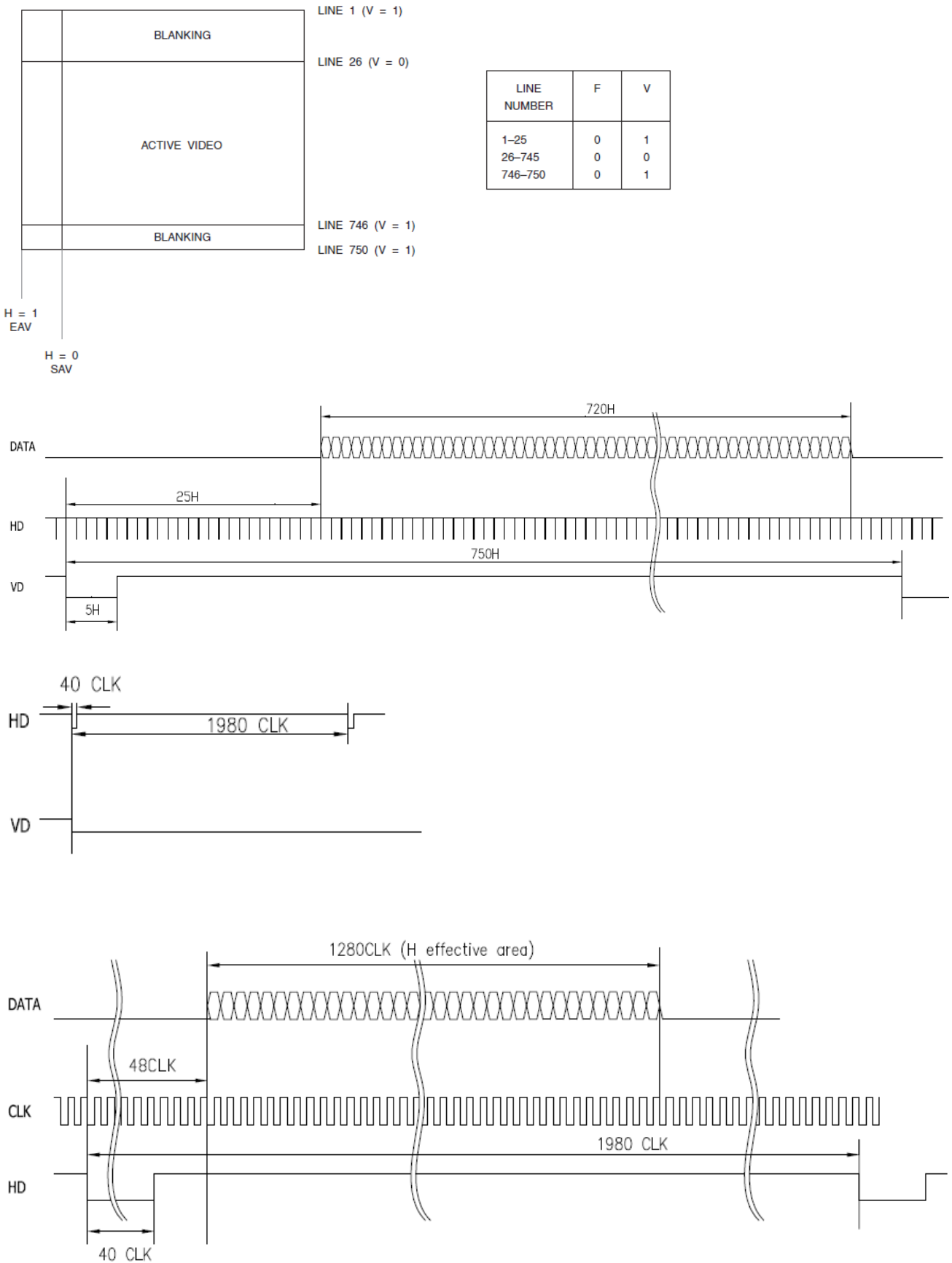

7.8. Video Data Start/Stop Format

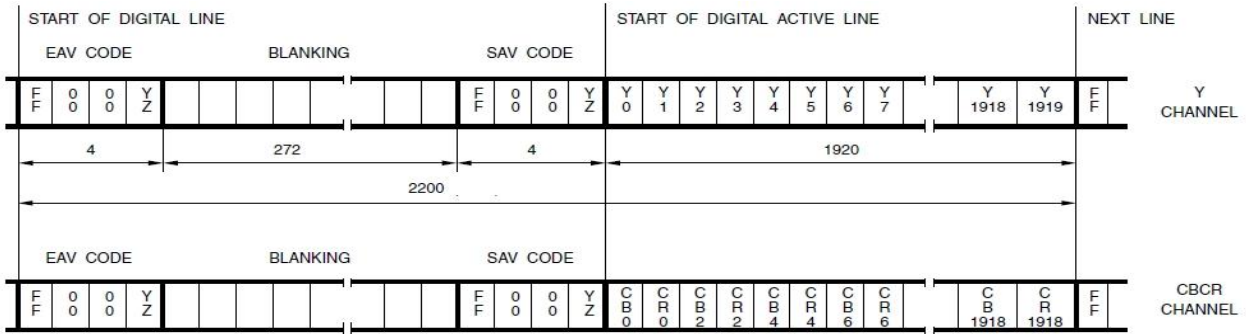

EAV and SAV CODE

	D7(MSB)	D6	D5	D4	D3	D2	D1	D0(LSB)
Preamble	1	1	1	1	1	1	1	1
	0	0	0	0	0	0	0	0
	0	0	0	0	0	0	0	0
Status word	1	F	V	H	P3	P2	P1	P0

EAV and SAV Sequence

The EAV and SAV sequences are shown in Table A. The status word is defined as:

F = "0" or "1" (Selectable)

V = "1" during vertical blanking

H = "0" at SAV H = "1" at EAV

P3-P0 = protection bits

$$P3 = V \oplus H$$

$$P2 = F \oplus H$$

$$P1 = F \oplus V$$

$$P0 = F \oplus V \oplus H$$

8. Camera Interface

8.1. Camera Interface

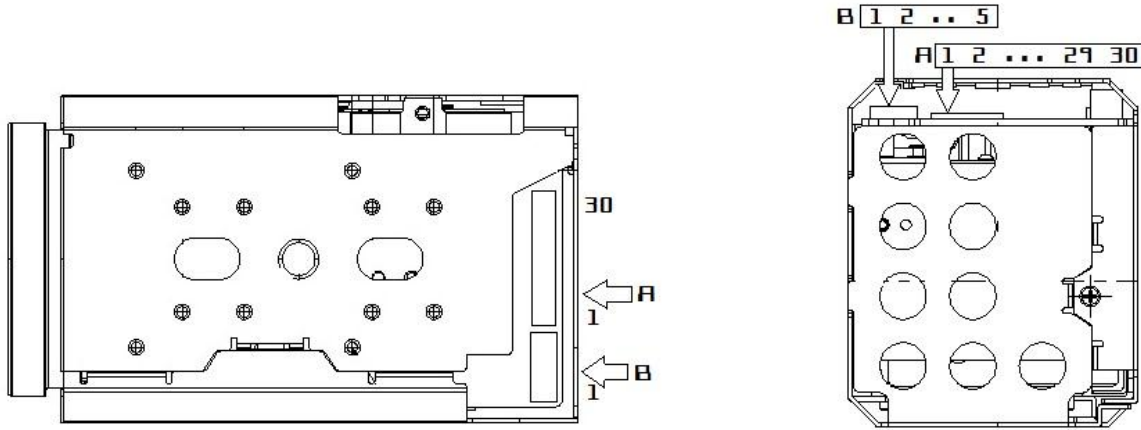

A connector :Recommended cable ASSY :

Cables - micro coaxial cable #42AWG

Connectors - USL20-30S (KEL)

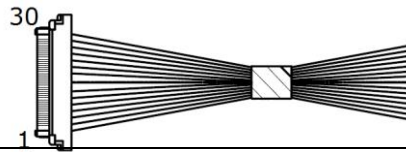

KEL USL00-30L			
1	TXOUT3+ (LVDS)	16	DC (9~15V)
2	TXOUT3- (LVDS)	17	DC (9~15V)
3	TXCLKOUT+ (LVDS)	18	DC (9~15V)
4	TXCLKOUT- (LVDS)	19	KEY input (optional)
5	TXOUT2+ (LVDS)	20	GND
6	TXOUT2- (LVDS)	21	TXOUT7+ (LVDS)
7	TXOUT1+ (LVDS)	22	TXOUT7- (LVDS)
8	TXOUT1- (LVDS)	23	TXOUT6+ (LVDS)
9	TXOUT0+ (LVDS)	24	TXOUT6- (LVDS)
10	TXOUT0- (LVDS)	25	
11	GND	26	EXT. Reset :Reset Low(GND), Normal Open(3.3V)
12	TXD (UART 5V output)	27	TXOUT5+ (LVDS)
13	RXD (UART 5V input)	28	TXOUT5- (LVDS)
14	DC (9~15V)	29	TXOUT4+ (LVDS)
15	DC (9~15V)	30	TXOUT4- (LVDS)

B connector:

Connector – Yeonho 12512WR-05 (1.25mm pitch)

	12512WR-05
1	TXD (UART 5V output)
2	RXD (UART 5V input)
3	KEY input
4	GND
5	DC (9~15V) power input

8.2. LVDS Interface

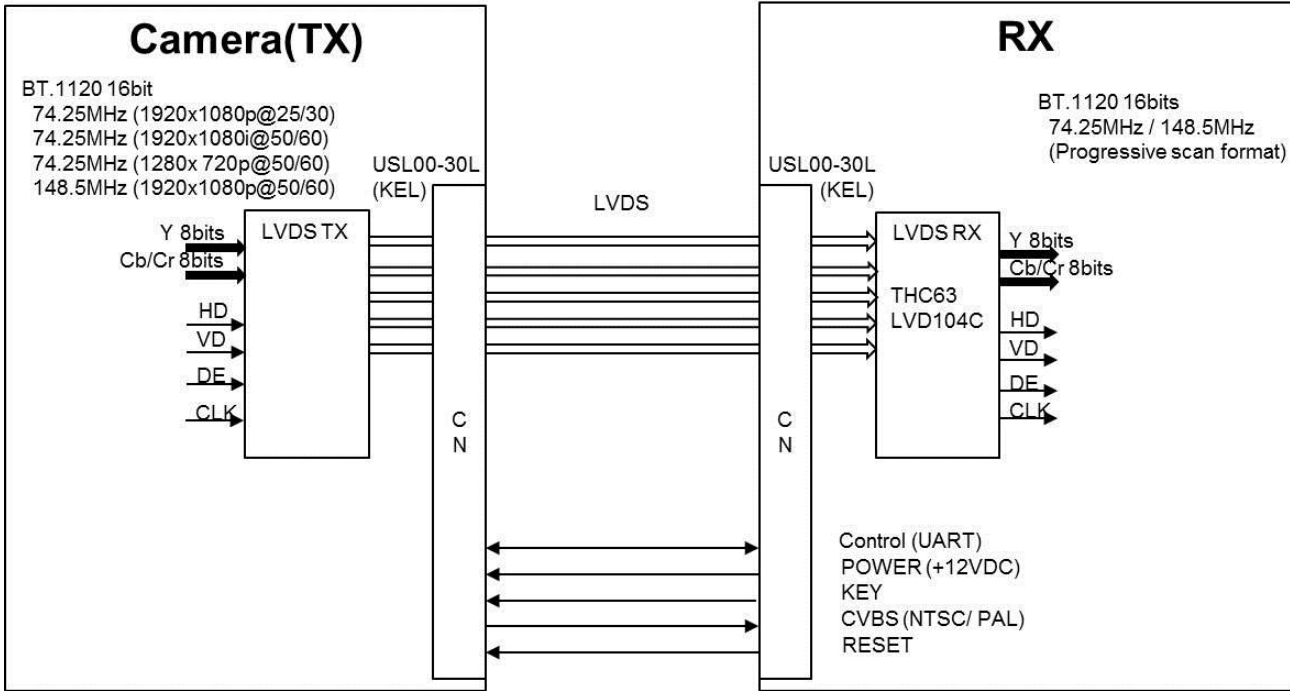

LVDS Single Output only

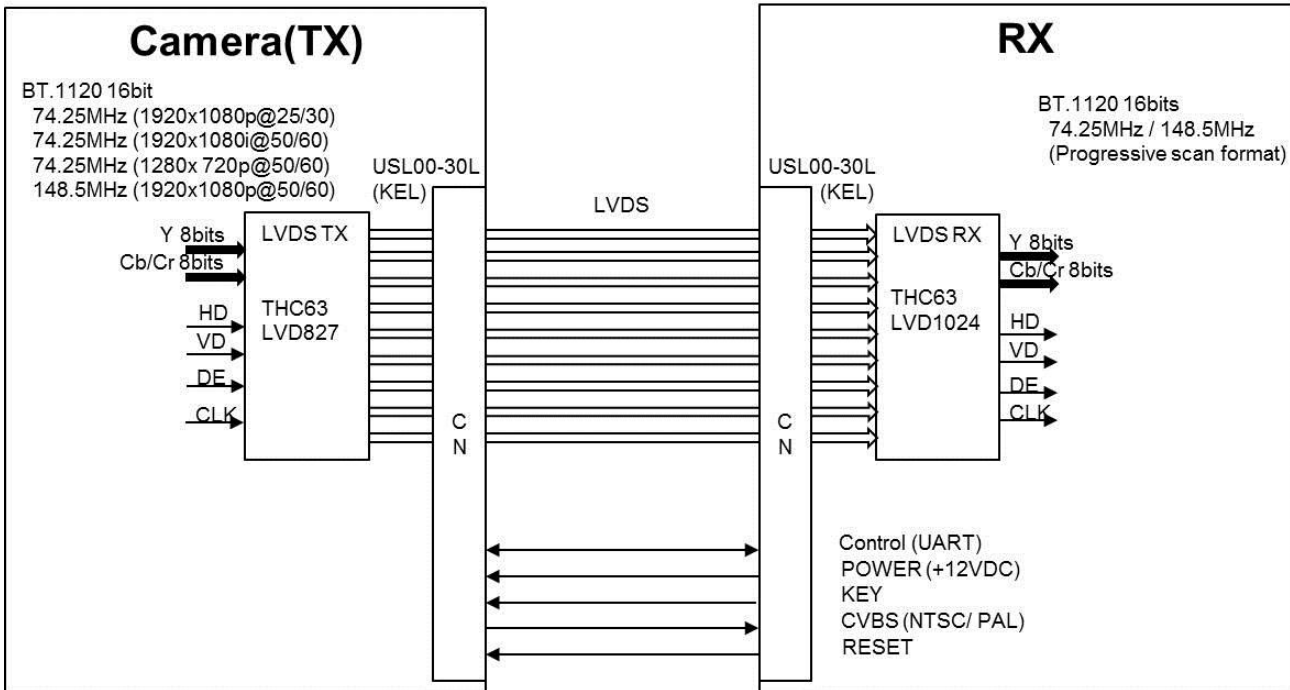

LVDS Single/Dual Output

LVDS Data Mapping

Single Mode (16bits)

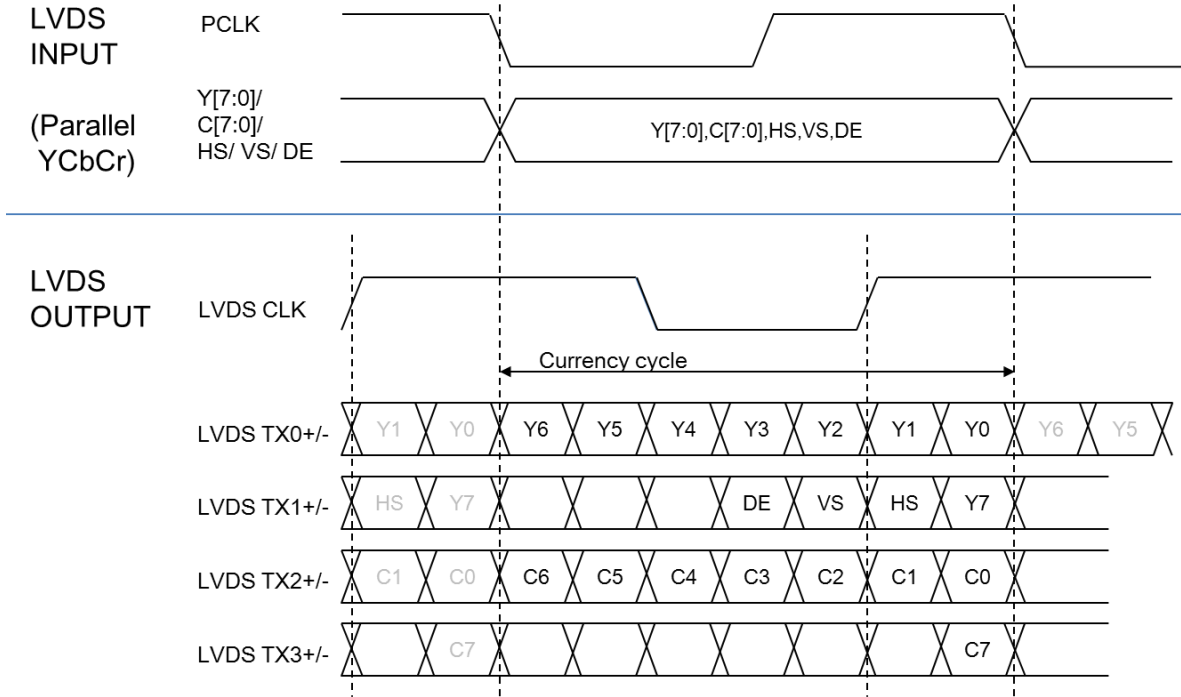

Single Mode (20bits)

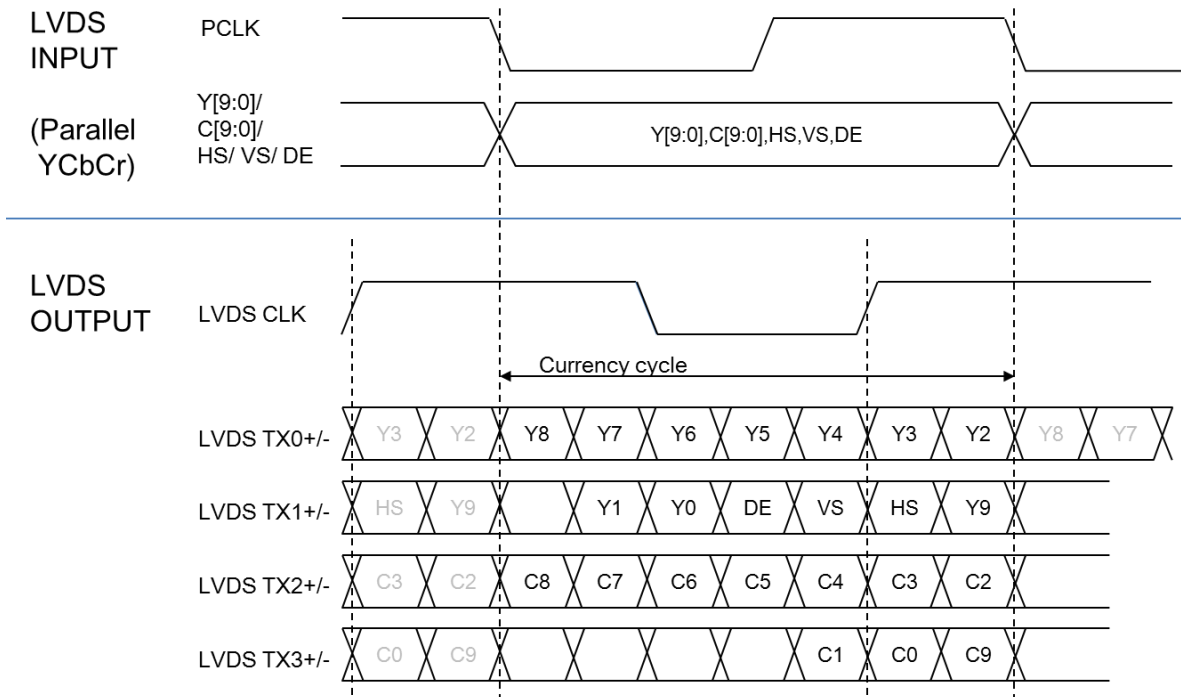

Dual Mode (16bits)

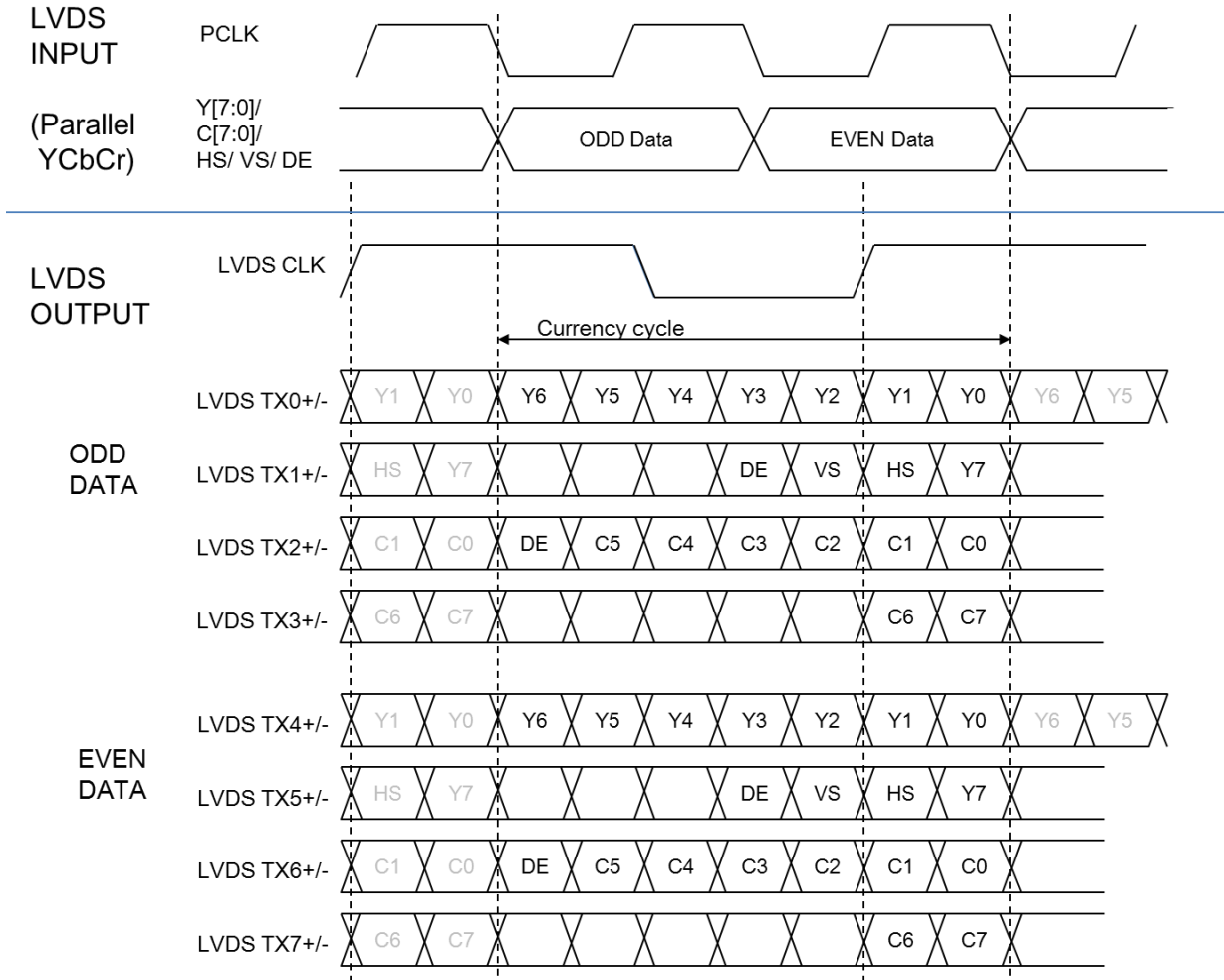

8.3. Key Application recommended circuit

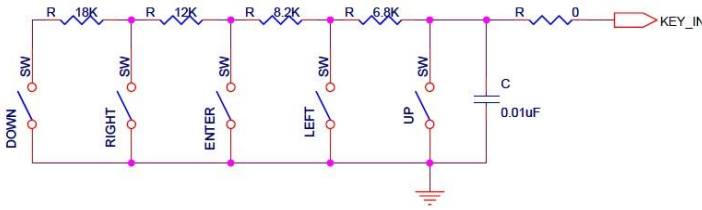

8.4. Application of recommended circuit Camera Reception

LVDS Rx(THC63LVD104C) circuit – 16bits

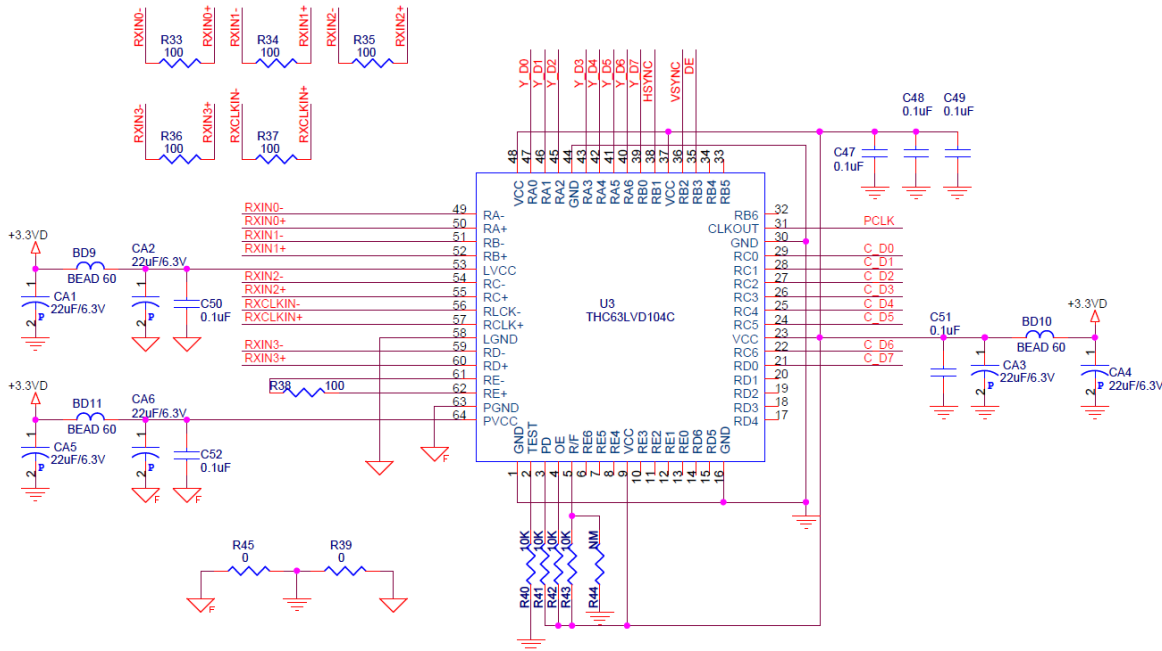

LVDS Rx(THC63LVD104C) circuit – 20bits

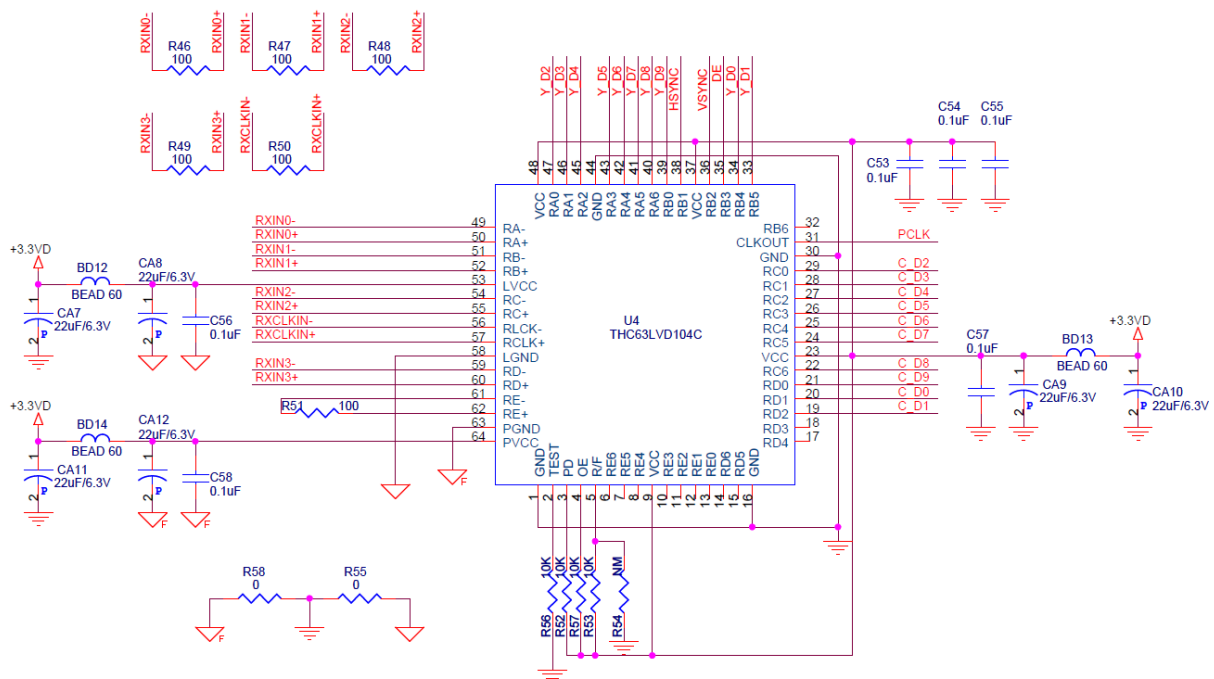

LVDS Rx(THC63LVD1024) circuit (Single output – 16bits)

[LVDS RX (Single Output) schematic]

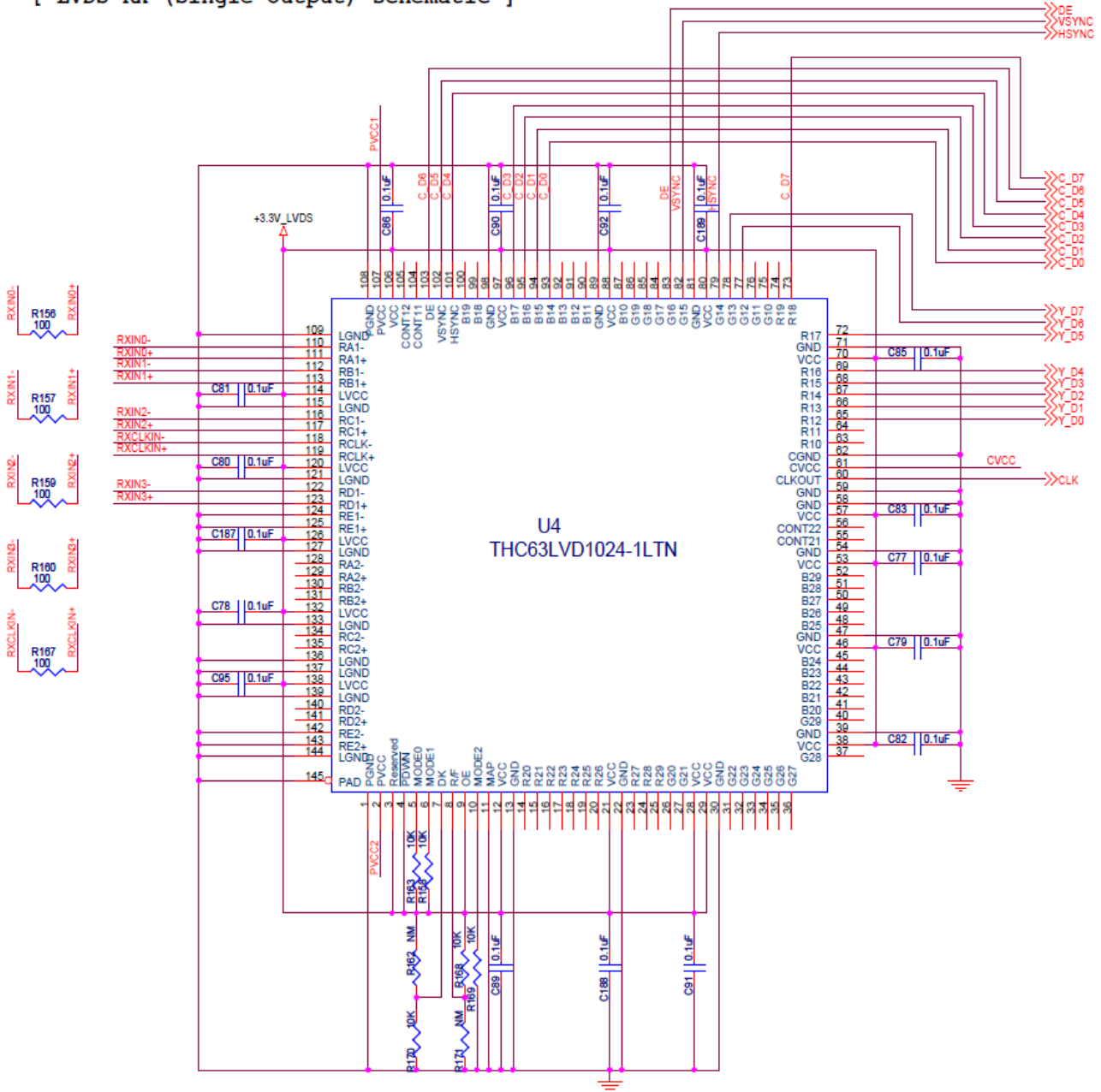

LVDS Rx(THC63LVD1024) circuit (Single output – 20bits)

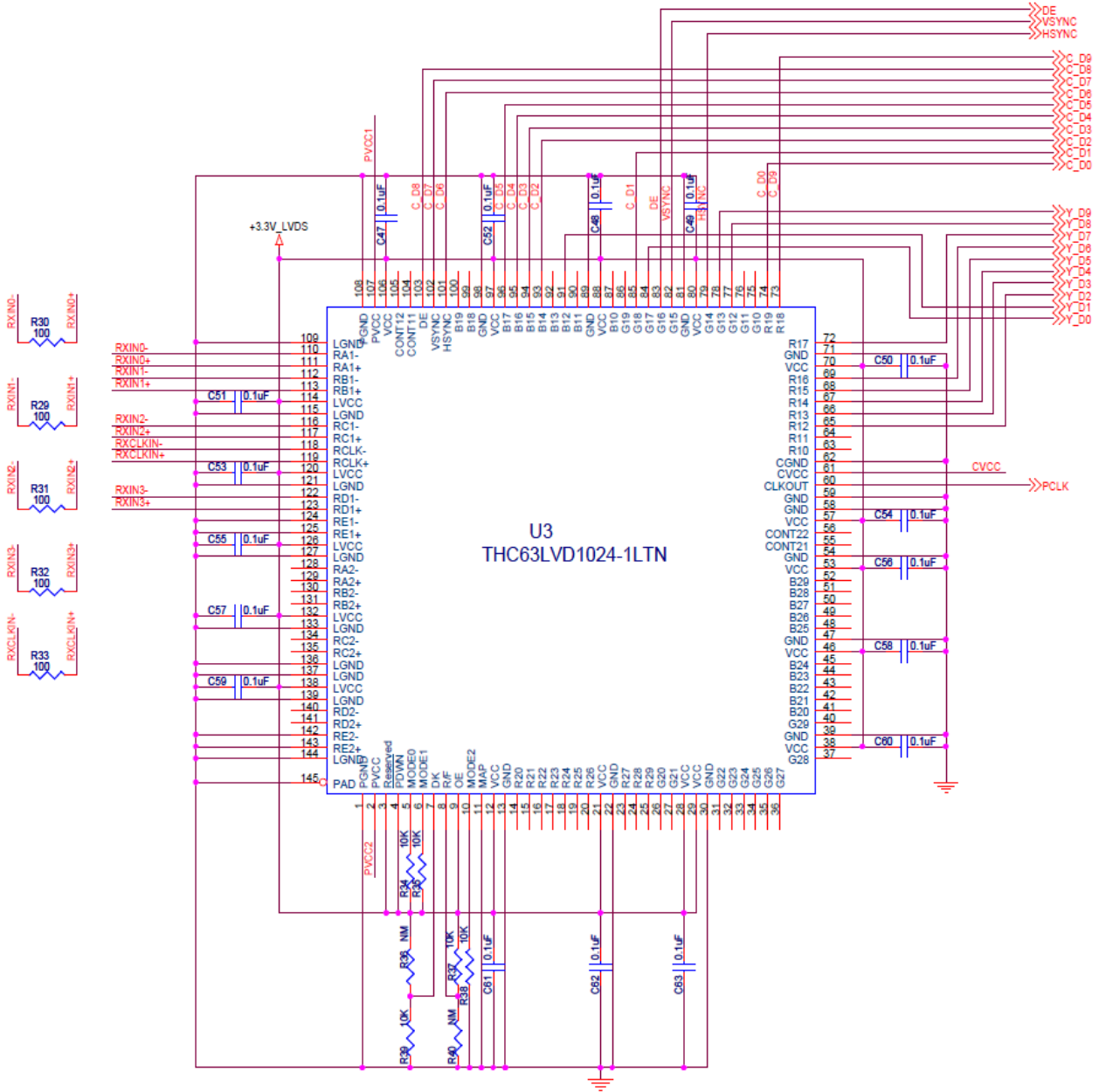

LVDS Rx(THC63LVD1024) circuit (Dual output - 16bits)

[LVDS RX (Dual Output) schematic]

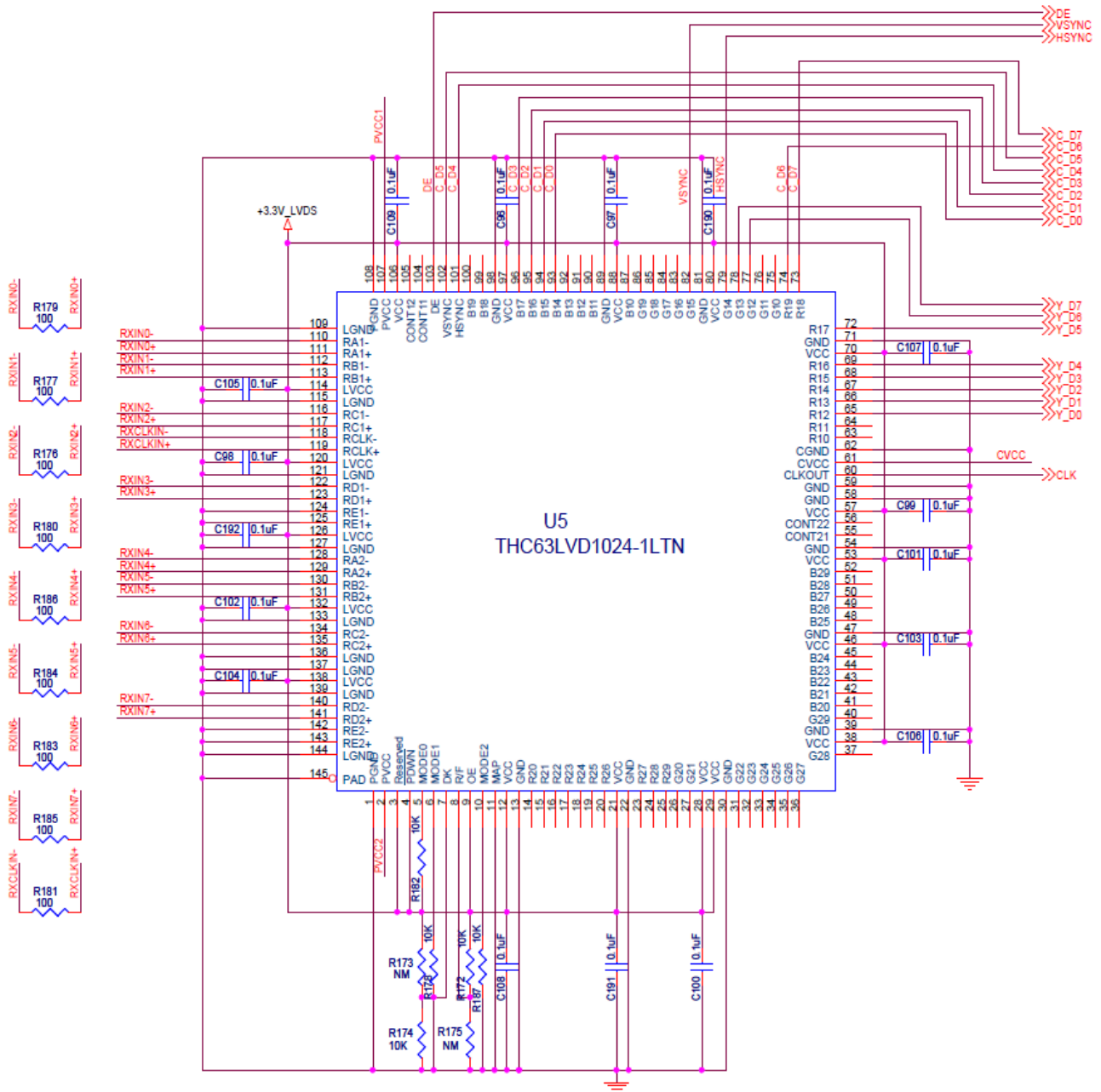

9. Dimensions

Front

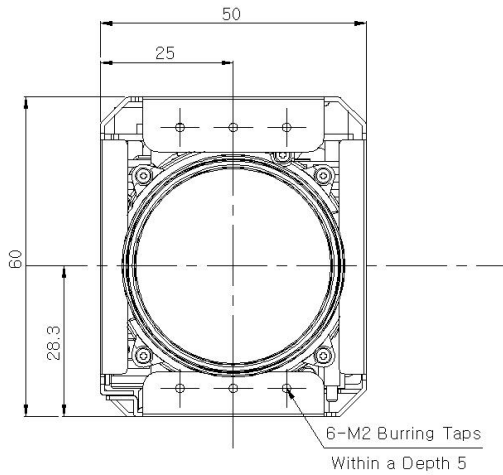

Top

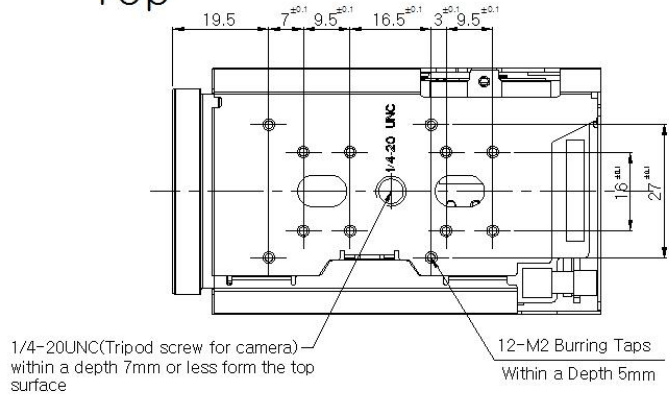

Back

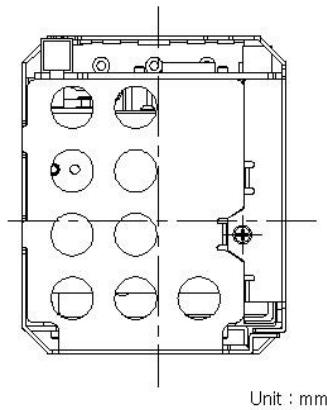

Bottom

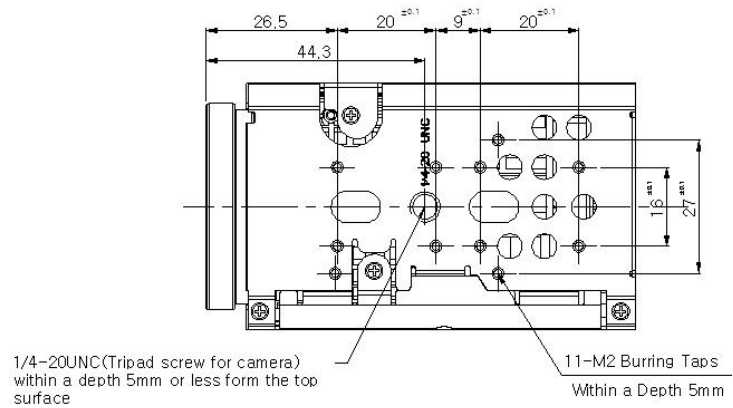

Left side

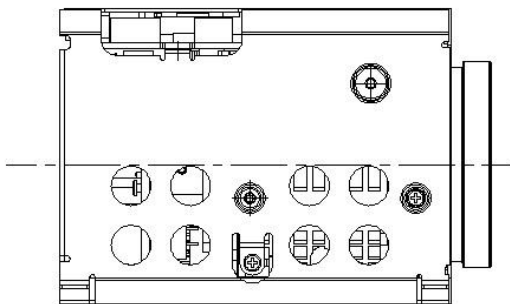

Right side

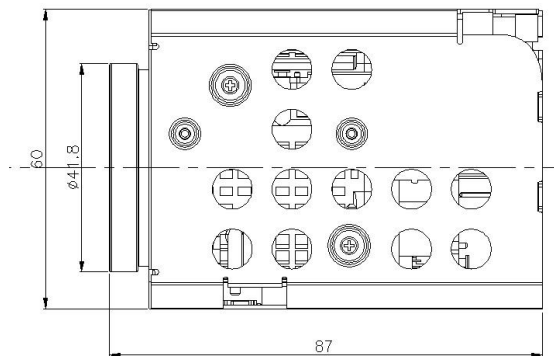

APPENDIX A

VISCA Protocol

9600, 19200, 38400, 115200bps 8bit data 1stop bit none parity

		Command Packet (3~ 16bytes)	Comments
Inquiry		8X QQ RR ... FF	8X: 0x80+Sender addr(H nibble)+Recv addr(L nibble) addr(1~7) QQ: 01-Command/ 00-Inquiry RR: Category 00(Interface) 04(cam1) 06(Pan/Tilt) 07(cam2) FF: Terminator (0xff)

		Reply Packet	
Completion message	ACK	X0 4Y FF	X = 9 to F: FCB camera address + 8
	Completion (commands)	X0 5Y FF	Y: socket number
	Completion (Inquiries)	X0 5Y ... FF	

		Reply Packet	
Error message	Error	X0 6Y 01 FF	Message length error (>14 bytes)
		X0 6Y 02 FF	Syntax Error
		X0 6Y 03 FF	Command buffer full
		X0 6Y 04 FF	Command cancelled
		X0 6Y 05 FF	No socket (to be cancelled)
		X0 6Y 41 FF	Command not executable
		X = 9 to F: FCB camera address + 8, Y = socket number	

Command execution cancel	cancel	8X 2Y FF	X = 1 to 7: FCB camera address, Y = socket number
--------------------------	--------	----------	--

Network Change Address	Address Network Change	88 30 01 FF . X0 38 FF	Always broadcasted X = 9 to F: FCB camera address + 8
------------------------	------------------------	---------------------------	--

	Command Packet	Reply Packet
IF_Clear	8X 01 00 01FF	X0 50 FF
IF_Clear (broadcast)	88 01 00 01 FF	88 01 00 01 FF

	Inquiry Packet	Reply Packet	
CAM_VersionInq	8X 09 00 02 FF	Y0 50 GG GG HH HH JJ JJ KK FF	GGGG = Vender ID 00BC: HHHH = Model ID 2201: MLC220 x20 1080p module 2121: MLC212 x12 1080p module 2200: MLC120 x20 CCD 720p module 2101: MLC210 x10 FullHD module 2103: MLC210U x10 FullHD module 2204: MLC220 x20 FullHD module 2300: MLC230 x30 FullHD module 2350: MLC235 x35 FullHD module 2051: MLC250 x5 FullHD module 2380: x3 motorized camera JJJJ = ROM revision KK = Maximum socket #(02)

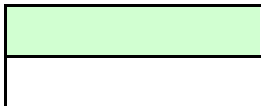

Supported Command

not Supported Command

Command Set

Command Set	Command	Packet	Comments
AddressSet	Broadcast	88 30 01 FF	Address setting
IF_Clear	Broadcast	88 01 00 01 FF	I/F Clear
CommandCancel		8x 2p FF	p: Socket No. (=1 or 2)
CAM_Power	On	8x 01 04 00 02 FF	Power ON/OFF (specific model *m1)
	Off(Standby)	8x 01 04 00 03 FF	
CAM_Zoom	Stop	8x 01 04 07 00 FF	
	Tele (Standard)	8x 01 04 07 02 FF	
	Wide (Standard)	8x 01 04 07 03 FF	
	Tele (Variable)	8x 01 04 07 2p FF	p=0 (Low) to 7 (High)
	Wide (Variable)	8x 01 04 07 3p FF	
	Direct (AF Zoom)	8x 01 04 47 0p 0q 0r 0s FF	pqrs: Zoom Position (refer Table) Auto Focusing during Zooming
	Direct (Non AF Zoom)	8x 01 04 45 0p 0q 0r 0s FF	pqrs: Zoom Position (refer Table) Non AF during Zooming
Direct (AF Zoom) variable	8x 01 04 47 0n 0p 0q 0r 0s FF	n: zoom speed 0(low) to 7(high) pqrs: Zoom Position (refer Table) Auto Focusing during Zooming	
CAM_DZoom	On	8x 01 04 06 02 FF	Digital zoom ON/OFF
	Off	8x 01 04 06 03 FF	
	Combine Mode	8x 01 04 36 00 FF	Optical/Digital Zoom Combined
	Separate Mode	8x 01 04 36 01 FF	Optical/Digital Zoom Separate
	Stop	8x 01 04 06 00 FF	
	Tele (Variable)	8x 01 04 06 2p FF	p=0 (Low) to 7 (High)
	Wide (Variable)	8x 01 04 06 3p FF	* Enabled during Separate Mode
	x1/Max	8x 01 04 06 10 FF	x1/MAX Magnification Switchover * Enabled during Separate Mode
Direct	8x 01 04 46 0p 0q 0r 0s FF	pq: D-Zoom Position * Enabled during Separate Mode	

Command Set

Command Set	Command	Packet	Comments
CAM_Focus	Stop	8x 01 04 08 00 FF	
	Far (Standard)	8x 01 04 08 02 FF	
	Near (Standard)	8x 01 04 08 03 FF	
	Far (Variable)	8x 01 04 08 2p FF	p=0 (Low) to 7 (High)
	Near (Variable)	8x 01 04 08 3p FF	
	Direct	8x 01 04 48 0p 0q 0r 0s FF	pqrs: Focus Position (0x1000 - 0xC000)
	Auto Focus	8x 01 04 38 02 FF	AF ON/OFF
	Manual Focus	8x 01 04 38 03 FF	
	Auto/Manual	8x 01 04 38 10 FF	
	One Push Trigger	8x 01 04 18 01 FF	One Push AF Trigger
	<i>Infinity</i>	<i>8x 01 04 18 02 FF</i>	<i>Forced infinity</i>
Near Limit	8x 01 04 28 0p 0q 0r 0s FF	pqrs: Focus Near Limit Position (Not recommend this command Use Register Near/Far Limit command)	
AF Sensitivity	Normal	8x 01 04 58 02 FF	AF Sensitivity High/Low
	Low	8x 01 04 58 03 FF	
CAM_AFMMode	Normal AF	8x 01 04 57 00 FF	AF Movement Mode
	<i>Interval AF</i>	<i>8x 01 04 57 01 FF</i>	
	<i>Zoom Trigger AF</i>	<i>8x 01 04 57 02 FF</i>	
	<i>Active/Interval Time</i>	<i>8x 01 04 27 0p 0q 0r 0s FF</i>	<i>pq: Movement Time, rs: Interval</i>
CAM_IRCorrection	<i>Standard</i>	<i>8x 01 04 11 00 FF</i>	<i>FOCUS IR compensation data switching</i>
	<i>IR Light</i>	<i>8x 01 04 11 01 FF</i>	
CAM_ZoomFocus	Direct	8x 01 04 47 0p 0q 0r 0s 0t 0u	pqrs: Zoom Position (refer Table)
		0v 0w FF	tuvw: Focus Position
CAM_ZoomFocus variable	Direct	8x 01 04 47 0n 0p 0q 0r 0s 0t 0u 0v 0w FF	n: zoom speed 0(low) to 7(high) pqrs: Zoom Position (refer Table) tuvw: Focus Position
CAM_Initialize	Lens	8x 01 04 19 01 FF	Lens Initialization Start
	Camera	8x 01 04 19 03 FF	Camera reset

Command Set

Command Set	Command	Packet	Comments
CAM_WB	Auto	8x 01 04 35 00 FF	Normal Auto
	Indoor	8x 01 04 35 01 FF	Indoor mode
	Outdoor	8x 01 04 35 02 FF	Outdoor mode
	One Push WB	8x 01 04 35 03 FF	One Push WB mode
	ATW	8x 01 04 35 04 FF	Auto Tracing White Balance
	Manual	8x 01 04 35 05 FF	Manual Control mode
	One Push Trigger	8x 01 04 10 05 FF	One Push WB Trigger
	<i>Outdoor Auto</i>	<i>8x 01 04 35 06 FF</i>	<i>Outdoor auto</i>
	<i>Sodium Lamp Auto</i>	<i>8x 01 04 35 07 FF</i>	<i>Auto including sodium lamp source</i>
<i>Sodium Lamp</i>	<i>8x 01 04 35 08 FF</i>	<i>Sodium lamp source fixed mode</i>	
CAM_RGain	Reset	8x 01 04 03 00 FF	Manual Control of R Gain
	Up	8x 01 04 03 02 FF	
	Down	8x 01 04 03 03 FF	
	Direct	8x 01 04 43 00 00 0p 0q FF	pq: R Gain (0 to 0xFF)
CAM_BGain	Reset	8x 01 04 04 00 FF	Manual Control of B Gain
	Up	8x 01 04 04 02 FF	
	Down	8x 01 04 04 03 FF	
	Direct	8x 01 04 44 00 00 0p 0q FF	pq: B Gain (0 to 0xFF)
CAM_AE	Full Auto	8x 01 04 39 00 FF	Automatic Exposure mode
	Manual	8x 01 04 39 03 FF	Manual Control mode
	Shutter Priority	8x 01 04 39 0A FF	Shutter Priority Automatic Exposure mode
	Iris Priority	8x 01 04 39 0B FF	Iris Priority Automatic Exposure mode
	Bright	8x 01 04 39 0D FF	Bright Mode (Manual control)
CAM_SlowShutter	Auto	8x 01 04 5A 02 FF	Auto Slow Shutter ON/OFF
	Manual	8x 01 04 5A 03 FF	
CAM_Shutter	Reset	8x 01 04 0A 00 FF	Shutter Setting
	Up	8x 01 04 0A 02 FF	
	Down	8x 01 04 0A 03 FF	
	Direct	8x 01 04 4A 00 00 0p 0q FF	pq: Shutter Position (refer Table)
CAM_Iris	Reset	8x 01 04 0B 00 FF	Iris Setting
	Up	8x 01 04 0B 02 FF	
	Down	8x 01 04 0B 03 FF	
	Direct	8x 01 04 4B 00 00 0p 0q FF	pq: Iris Position (0 to 0x11) (refer Table)

Command Set

Command Set	Command	Packet	Comments
CAM_Gain	Reset	8x 01 04 0C 00 FF	Gain Setting
	Up	8x 01 04 0C 02 FF	
	Down	8x 01 04 0C 03 FF	
	Direct	8x 01 04 4C 00 00 0p 0q FF	pq: Gain Position (0 to 0x0F) (refer Table)
	Gain Limit	8x 01 04 2C 0p FF	p: Gain Position (refer Table)
CAM_Bright	Reset	8x 01 04 0D 00 FF	Bright Setting
	Up	8x 01 04 0D 02 FF	
	Down	8x 01 04 0D 03 FF	
	Direct	8x 01 04 4D 00 00 0p 0q FF	pq: Bright Position (0 to 0x1f) (refer Table)
CAM_ExpComp	On	8x 01 04 3E 02 FF	Exposure Compensation ON/OFF
	Off	8x 01 04 3E 03 FF	
	Reset	8x 01 04 0E 00 FF	Exposure Compensation Amount Setting
	Up	8x 01 04 0E 02 FF	
	Down	8x 01 04 0E 03 FF	
	Direct	8x 01 04 4E 00 00 0p 0q FF	pq: ExpComp Position (0 to 0x0E)
CAM_BackLight	On	8x 01 04 33 02 FF	Back Light Compensation ON/OFF
	Off	8x 01 04 33 03 FF	
CAM_SpotAE	On	8x 01 04 59 02 FF	Spot Automatic Exposure Setting
	Off	8x 01 04 59 03 FF	
	Position	8x 01 04 29 0p 0q 0r 0s FF	pq: X (0 to F), rs: Y (0 to F)
CAM_AEResponse	Direct	8x 01 04 5D pp FF	pp: Automatic Exposure Response Setting (01 to 30)
CAM_WD	On	8x 01 04 3D 02 FF	Wide-D ON/OFF
	Off	8x 01 04 3D 03 FF	
	VE On	8x 01 04 52 02 FF	VE On
	Set Parameter	8x 01 04 2D 00 0q 0r 0s 00 00 00 00 FF	q: Display brightness level(0:Dark to 6:Bright) r: Brightness compaensation selection (0: Very dark 1: Dark 2: Standard 3: Bright) r: Blocked-up shadow correction level (0: L 1: M 2: H 3: S) S: Compensation level (0: L 1: M 2: H)

Command Set

Command Set	Command	Packet	Comments
CAM_Aperture	Reset	8x 01 04 02 00 FF	Aperture Control
	Up	8x 01 04 02 02 FF	
	Down	8x 01 04 02 03 FF	
	Direct	8x 01 04 42 00 00 0p 0q FF	pq: Aperture Gain (0 to 0x14) (refer Table)
CAM_HR	On	8x 01 04 52 02 FF	High-Resolution Mode ON/OFF
	Off	8x 01 04 52 03 FF	
CAM_NR		8x 01 04 53 0p FF	p: NR Setting (0: OFF, level 1 to 3)
CAM_Gamma		8x 01 04 5B 0p FF	p: Gamma setting (0: Standard, 1 to 4)
CAM_HighSensitivity	On	8x 01 04 5E 02 FF	High Sensitivity mode ON/OFF
	Off	8x 01 04 5E 03 FF	
CAM_LR_Reverse	On	8x 01 04 61 02 FF	Mirror Image ON/OFF
	Off	8x 01 04 61 03 FF	
CAM_Freeze	On	8x 01 04 62 02 FF	Still Image ON/OFF
	Off	8x 01 04 62 03 FF	
CAM_PictureEffect	Off	8x 01 04 63 00 FF	Picture Effect Setting
	Neg.Art	8x 01 04 63 02 FF	
	B&W	8x 01 04 63 04 FF	
CAM_Defog	On	8x 01 04 37 02 0p FF	p:Defog level (0:auto, 1:low, 2:mid, 3:high)
	Off	8x 01 04 37 03 00 FF	
CAM_PictureFlip	On	8x 01 04 66 02 FF	Picture flip ON/OFF
	Off	8x 01 04 66 03 FF	
CAM_MinShutter	On	8x 01 04 12 02 FF	
	Off	8x 01 04 12 03 FF	
	Limit	8x 01 04 13 00 00 0p 0q FF	pq: Minimum Shutter Position (05h to 15h)
CAM_ICR	On	8x 01 04 01 02 FF	Infrared Mode ON/OFF
	Off	8x 01 04 01 03 FF	
CAM_AutoICR	On	8x 01 04 51 02 FF	Auto dark-field mode On/Off
	Off	8x 01 04 51 03 FF	
	Threshold	8x 01 04 21 00 00 0p 0q FF	pq: ICR On/Off Threshold Level(0 to 0x14)
CAM_AutoICR AlarmReply	On	8x 01 04 31 02 FF	Auto ICR switching Alarm ON/OFF
	Off	8x 01 04 31 03 FF	
	(Reply)	y0 07 04 31 02 FF	ICR OFF -> ON
		y0 07 04 31 03 FF	ICR ON -> OFF

Command Set

Command Set	Command	Packet	Comments																																																																																																			
CAM_Stabilizer	On	8x 01 04 34 02 FF	Stabilizer ON/OFF/HOLD																																																																																																			
	Off	8x 01 04 34 03 FF																																																																																																				
	Hold	8x 01 04 34 00 FF																																																																																																				
CAM_Memory (Preset pos)	Reset	8x 01 04 3F 00 0p FF	p: Memory Number (=0 to 6)																																																																																																			
	Set	8x 01 04 3F 01 0p FF																																																																																																				
	Recall	8x 01 04 3F 02 0p FF																																																																																																				
CAM_CUSTOM	Reset	8x 01 04 3F 00 7F FF	Starts up in this mode when the power is turned on.																																																																																																			
	Set	8x 01 04 3F 01 7F FF																																																																																																				
	Recall	8x 01 04 3F 02 7F FF																																																																																																				
CAM_MemSave	Write	8x 01 04 23 0X 0p 0q 0r 0s FF	X: 00 to 07 (Address), total 16 byte pqrs: 0x0000 to 0xFFFF (Data)																																																																																																			
CAM_Display	On	8x 01 04 15 02 FF	Display ON/OFF																																																																																																			
	Off	8x 01 04 15 03 FF																																																																																																				
	On/Off	8x 01 04 15 10 FF																																																																																																				
CAM_MultiLineTitle	Title Set1	8x 01 04 73 1L 00 nn pp qq 00 00 00 00 00 00 FF	L: Line Number 0~0xA nn: H-position 0~0x1F pp: Color 0:WHT 1:YEL 2:MAG 3:RED qq: Blink 0:Not blink 1:Blinks																																																																																																			
	Title Set2	8x 01 04 73 2L mm nn pp qq rr ss tt uu vv ww FF	L: Line Number, mnpqrstuvw: Setting of characters (1 to 10)																																																																																																			
	Title Set3	8x 01 04 73 3L mm nn pp qq rr ss tt uu vv ww FF	L: Line Number, mnpqrstuvw: Setting of characters (11 to 20)																																																																																																			
			<table border="1"> <tr><td>A</td><td>B</td><td>C</td><td>D</td><td>E</td><td>F</td><td>G</td><td>H</td><td>0x00, 0x01, ..., 0x07</td></tr> <tr><td>I</td><td>J</td><td>K</td><td>L</td><td>M</td><td>N</td><td>O</td><td>P</td><td>0x08, 0x09, ..., 0x0f</td></tr> <tr><td>Q</td><td>R</td><td>S</td><td>T</td><td>U</td><td>V</td><td>W</td><td>X</td><td>0x10, 0x11, ..., 0x17</td></tr> <tr><td>Y</td><td>Z</td><td>&</td><td></td><td>?</td><td>!</td><td>1</td><td>2</td><td>0x18, 0x19, ..., 0x1f</td></tr> <tr><td>3</td><td>4</td><td>5</td><td>6</td><td>7</td><td>8</td><td>9</td><td>0</td><td>0x20, 0x21, ..., 0x27</td></tr> <tr><td></td><td></td><td></td><td></td><td></td><td></td><td></td><td></td><td>0x28, 0x29, ..., 0x2f</td></tr> <tr><td></td><td></td><td></td><td></td><td></td><td></td><td></td><td></td><td>0x30, 0x31, ..., 0x37</td></tr> <tr><td></td><td></td><td></td><td></td><td></td><td></td><td></td><td></td><td>0x38, 0x39, ..., 0x3f</td></tr> <tr><td></td><td>\$</td><td>←</td><td>→</td><td>↑</td><td>↓</td><td>↔</td><td>↔</td><td>0x40, 0x41, ..., 0x47</td></tr> <tr><td></td><td>"</td><td>:</td><td>'</td><td>-</td><td>,</td><td>/</td><td>-</td><td>0x48, 0x49, ..., 0x4f</td></tr> <tr><td>*</td><td></td><td></td><td></td><td></td><td></td><td></td><td></td><td>0x50, 0x51, ..., 0x57</td></tr> </table>	A	B	C	D	E	F	G	H	0x00, 0x01, ..., 0x07	I	J	K	L	M	N	O	P	0x08, 0x09, ..., 0x0f	Q	R	S	T	U	V	W	X	0x10, 0x11, ..., 0x17	Y	Z	&		?	!	1	2	0x18, 0x19, ..., 0x1f	3	4	5	6	7	8	9	0	0x20, 0x21, ..., 0x27									0x28, 0x29, ..., 0x2f									0x30, 0x31, ..., 0x37									0x38, 0x39, ..., 0x3f		\$	←	→	↑	↓	↔	↔	0x40, 0x41, ..., 0x47		"	:	'	-	,	/	-	0x48, 0x49, ..., 0x4f	*								0x50, 0x51, ..., 0x57
	A	B	C	D	E	F	G	H	0x00, 0x01, ..., 0x07																																																																																													
	I	J	K	L	M	N	O	P	0x08, 0x09, ..., 0x0f																																																																																													
	Q	R	S	T	U	V	W	X	0x10, 0x11, ..., 0x17																																																																																													
Y	Z	&		?	!	1	2	0x18, 0x19, ..., 0x1f																																																																																														
3	4	5	6	7	8	9	0	0x20, 0x21, ..., 0x27																																																																																														
								0x28, 0x29, ..., 0x2f																																																																																														
								0x30, 0x31, ..., 0x37																																																																																														
								0x38, 0x39, ..., 0x3f																																																																																														
	\$	←	→	↑	↓	↔	↔	0x40, 0x41, ..., 0x47																																																																																														
	"	:	'	-	,	/	-	0x48, 0x49, ..., 0x4f																																																																																														
*								0x50, 0x51, ..., 0x57																																																																																														
Title Clear	8x 01 04 74 1p FF	Title Setting clear (p: 0 to a, f= all lines)																																																																																																				
On	8x 01 04 74 2p FF	Title display On/Off (0 to a, f= all lines)																																																																																																				
Off	8x 01 04 74 3p FF																																																																																																					

Command Set

Command Set	Command	Packet	Comments
CAM_Mute	On	8x 01 04 75 02 FF	Muting ON/OFF
	Off	8x 01 04 75 03 FF	
	On/Off	8x 01 04 75 10 FF	
CAM_PrivacyZone	SetMask	8x 01 04 76 mm nn 0r 0r 0s 0s FF	mm: Mask Settings nn: 00-Modify, 01-New rr: W ss: H
	Display	8x 01 04 77 pp pp pp pp FF	Mask Display ON/OFF pp pp pp pp: Mask Settings (0: OFF, 1: ON)
	SetMaskColor	8x 01 04 78 pp pp pp pp qq rr FF	pp pp pp pp: Mask Color Settings qq: Color Setting when 0 is selected rr: Color Setting when 1 is selected
	SetPanTiltAngle	8x 01 04 79 0p 0p 0p 0q 0q 0q FF	Pan/Tilt Angle Settings ppp: Pan 0~4095(0xFFFF) 360/4096 Resolution qqq: Tilt 0~4095(0xFFFF) 360/4096 Resolution
	SetPTZMask	8x 01 04 7B mm 0p 0p 0p 0q 0q 0q 0r 0r 0r 0r FF	Pan/Tilt/Zoom Settings for Mask ppp: Pan 0~0xFFFF qqq: Tilt 0~0xFFFF rrrr: Zoom pos 0~0x4000
	Non_InterlockMask	8x 01 04 6F mm 0p 0p 0q 0q 0r 0r 0s 0s FF	mm: Non_Interlock Mask Settings pp: X, q: Y, rr: W, ss: H
	GridOn	8x 01 04 7C 02 FF	Grid Display ON/OFF
	GridOff	8x 01 04 7C 03 FF	Grid/Center Line Display Off
	CenterLineOn	8x 01 04 7C 04 FF	Center Line Display On
	CAM_IDWrite		8x 01 04 22 0p 0q 0r 0s FF

Command Set

Command Set	Command	Packet	Comments
CAM_Alarm	On	8x 01 04 6B 02 FF	Alarm ON/OFF
	Off	8x 01 04 6B 03 FF	
CAM_MD	On	8x 01 04 1B 02 FF	Motion Detection On/Off
	Off	8x 01 04 1B 03 FF	
	Function Set	8x 01 04 1C 0m 0n 0p 0q 0r 0s FF	m: Display mode 0-Off 1-On n: Detection Frame Set bit0-Frame0 bit1-Frame1 bit2-Frame2 pq: Threshold Level (00 to 0x14) <i>rs: Interval Time set (00 to 0xF)</i>
	Window Set	8x 01 04 1D 0m pp qq rr ss FF	m: Select Detection Frame (0, 1, 2) pp: Start Horizontal Position (00 to 0x3C) qq: Start Vertical Position (00 to 0x28) rr: Stop Horizontal Position (01 to 0x3C) ss: Stop Vertical Position (01 to 0x28)
	Alarm (Reply)	y0 07 04 1B 0p FF	p: Detection Frame Number
CAM_Continuous ZoomPosReply	On	8x 01 04 69 02 FF	ZoomPosition data Continuous Output On/Off
	Off	8x 01 04 69 03 FF	
	(Reply)	y0 07 04 69 0p 0p 0q 0q 0q 0q FF	
CAM_ZoomPosReplyIntervalTimeSet		8x 01 04 6A 00 00 0p 0p FF	pp: Interval Time [Vertical timing]

Command Set

Command Set	Command	Packet	Comments
CAM_Continuous FocusPosReply	On	8x 01 04 16 02 FF	FocusPosition data Continuous Output On/Off
	Off	8x 01 04 16 03 FF	
	(Reply)	y0 07 04 16 00 00 0p 0p 0p 0p FF	pppp: Focus Position
CAM_FosPosReply IntervalTimeSet		8x 01 04 6A 00 00 0p 0p FF	pp: Interval Time [Vertical timing]
CAM_Register Value		8x 01 04 24 mm 0p 0p FF	mm: Register No. (=00-7F) pp: Register Value (=00-7F)
CAM_ ColorEnhance	Parameter Set	8x 01 04 20 mm nn pp qq rr FF	mm: First byte from the top threshold value nn: Second byte from the top threshold value pp: Third byte from the top threshold value qq: Color specification for high-intensity rr: Color specification for low-intensity Range for mm, nn, and pp is 0 to F. Range for qq and rr is 0 to 8. Colors 0: Yellow, 1: Cyan, 2: Green, 3: White, 4: Magenta, 5: Red, 6: Blue, 7: Black, 8: Gray
	On	8x 01 04 50 02 FF	Color Enhancement ON/OFF
	Off	8x 01 04 50 03 FF	
CAM_ ChromaSuppress		8x 01 04 5F pp FF	pp: Chroma Suppress setting level 00: OFF 1 to 3: ON (3 levels). Effect increases as the level number increases.
CAM_ColorGain	Direct	8x 01 04 49 00 00 00 0p FF	p: Color Gain setting 0h (60%) to Eh (200%)
CAM_ColorHue	Direct	8x 01 04 4F 00 00 00 0p FF	p: Color Hue setting 0h (– 14 degrees) ~ Eh (+14 degrees)
CAM_HLC		8x 01 04 14 0p 0q FF	p: HLC level (0: OFF, 1: ON) q: HLC mask level (0 to F: from low to high level)
CAM_Menu		8x 01 06 06 pp FF	pp: 2-ON 3-OFF 0-BACK 11-UP 12-DOWN 14-LEFT 18-RIGHT

Register Set

Command Set	Command	Packet	Comments
BaudRate		8x 01 04 24 00 00 0p FF	p: 0-9600 1-19200 2-38400 3-115200
Monitoring Mode		8x 01 04 24 72 0p 0p FF	pp: 1-1080i@59.94 (specific model) 2-1080i@60 3- 4-1080i@50 5- 6-1080p@29.97 (specific model) 7-1080p@30 8-1080p@25 9-720p@59.94 (specific model) A-720p@60 B- C-720p@50 D- E-720p@29.97 (specific model) F-720p@30 10- 11-720p@25 12- 13-1080p@59.94 (specific model) 14-1080p@50 15-1080p@60
Output enable		8x 01 04 24 73 00 0p FF	p: 2-LVDS output On 4-SDI output On
LVDS Mode		8x 01 04 24 74 00 0p FF	p: 0-LVDS Single output 1-Dual Output
Wide limit		8x 01 04 24 50 0p 0p FF	pp: 0~FF refer Table
Tele limit		8x 01 04 24 51 0p 0p FF	pp: 0~FF refer Table
D-Zoom Max		8x 01 04 24 52 0p 0p FF	pp: Max D-zoom ratio = 256/ (256-pp)
Stable Zoom		8x 01 04 24 53 00 0p FF	p: 0-OFF 1-ON
Focus Trace		8x 01 04 24 54 00 0p FF	p: 0-OFF 1-ON
Focus Offset		8x 01 04 24 55 0p 0p FF	pp: 0-FF
Auto Slow Shutter		8x 01 04 24 59 00 0p FF	p: 1-1/30 2-1/15 3-1/8 4-1/4 5-1/2 6-1/1

Limit		
Shading	8x 01 04 24 1B 00 0p FF	p: 0-OFF 1-ON
D/N Margin	8x 01 04 24 28 0p 0p FF	pp: Margin 0~20
D/N DWell Time	8x 01 04 24 29 0p 0p FF	pp: DWELL time 1~20
Night Burst on	8x 01 04 24 30 00 0p FF	p: 0-OFF 1-ON
E-Clipse On	8x 01 04 24 2D 00 0p FF	p: 0-OFF 1-ON
E-Clipse Level	8x 01 04 24 2E 0p 0p FF	pp: HighLight Level 0~20
E-Clipse Color	8x 01 04 24 2F 00 0p FF	p: MaskColor 0:WHT 1:YEL 2:CYN 3:GRN 4:MAG 5:RED 6:BLU 7:BLK
PrvMaskTrans	8x 01 04 24 3A 00 0p FF	p: Privacy Mask Transparency 0-4
Flickerless	8x 01 04 24 3D 00 0p FF	p: 0-OFF 1-ON
AE_InOutdoor	8x 01 04 24 4B 00 0p FF	p: 0-AE Indoor Mode 1-AE Outdoor Mode
Contrast	8x 01 04 24 76 0p 0p FF	pp: 0~0x40(64)
EdgeColorSuppress	8x 01 04 24 80 0p 0q FF	p:0~F (edge color suppression -WDR mode) q:0~F (edge color suppression -Normal)
Focus Near Limit	8x 01 04 24 5F 00 0p FF	p: Near Limit 0-30Cm, 1-1M, 2-1.5M, 3-2M, 4-3M, 5-5M, 6-10M
Focus Far Limit	8x 01 04 24 60 00 0p FF	p: Far Limit 0-2M, 1-3M, 2-5M, 3-10M, 4-Infinity
NightSatLevel	8x 01 04 24 7C 00 0p FF	p: 0-Off 1(Low) ~ 20(High)

Inquiry Command

Inquiry Command	Command Packet	Inquiry Packet	Comments
CAM_PowerInq	8x 09 04 00 FF	y0 50 02 FF	On
		y0 50 03 FF	Off(Standby)
CAM_ZoomPosInq	8x 09 04 47 FF	y0 50 0p 0q 0r 0s FF	pqrs: Zoom Position (refer Table)
CAM_DZoomModelInq	8x 09 04 06 FF	y0 50 02 FF	D-Zoom On
		y0 50 03 FF	D-Zoom Off
CAM_Dzoom C/SModelInq	8x 09 04 36 FF	y0 50 00 FF	Combine Mode
		y0 50 01 FF	Separate Mode
CAM_DZoomPosInq	8x 09 04 46 FF	y0 50 00 00 0p 0q FF	pq: D-Zoom Position
CAM_FocusModelInq	8x 09 04 38 FF	y0 50 02 FF	Auto Focus
		y0 50 03 FF	Manual Focus
CAM_FocusPosInq	8x 09 04 48 FF	y0 50 0p 0q 0r 0s FF	pqrs: Focus Position (0x1000 - 0xC000)
CAM_FocusNearLimitInq	8x 09 04 28 FF	y0 50 0p 0q 0r 0s FF	pqrs: Focus Near Limit Position
CAM_AFSensitivityInq	8x 09 04 58 FF	y0 50 02 FF	AF Sensitivity Normal
		y0 50 03 FF	AF Sensitivity Low
CAM_AFModelInq	8x 09 04 57 FF	y0 50 00 FF	Normal AF
		y0 50 01 FF	Interval AF
		y0 50 02 FF	Zoom Trigger AF
CAM_AFTimeSettingInq	8x 09 04 27 FF	y0 50 0p 0q 0r 0s FF	pq: Movement Time rs: Interval Time
CAM_IRCorrectionInq	8x 09 04 11 FF	y0 50 02 FF	Standard
		y0 50 03 FF	IR Light
CAM_WBModelInq	8x 09 04 35 FF	y0 50 00 FF	Auto
		y0 50 01 FF	InDoor
		y0 50 02 FF	OutDoor
		y0 50 03 FF	One Push WB
		y0 50 04 FF	ATW
		y0 50 05 FF	Manual
		y0 50 06 FF	Outdoor Auto
		y0 50 07 FF	Sodium Lamp Auto
y0 50 08 FF	Sodium Lamp		
CAM_RGainInq	8x 09 04 43 FF	y0 50 00 00 0p 0q FF	pq: R Gain
CAM_BGainInq	8x 09 04 44 FF	y0 50 00 00 0p 0q FF	pq: B Gain

Inquiry Command

Inquiry Command	Command Packet	Inquiry Packet	Comments
CAM_AEModeInq	8x 09 04 39 FF	y0 50 00 FF	Full Auto
		y0 50 03 FF	Manual
		y0 50 0A FF	Shutter Priority
		y0 50 0B FF	Iris Priority
		y0 50 0D FF	Bright
CAM_SlowShutterModeInq	8x 09 04 5A FF	y0 50 02 FF	Auto
		y0 50 03 FF	Manual
CAM_ShutterPosInq	8x 09 04 4A FF	y0 50 00 00 0p 0q FF	pq: Shutter Position
CAM_IrisPosInq	8x 09 04 4B FF	y0 50 00 00 0p 0q FF	pq: Iris Position
CAM_GainPosInq	8x 09 04 4C FF	y0 50 00 00 0p 0q FF	pq: Gain Position
CAM_GainLimitInq	8x 09 04 2C FF	y0 50 0p FF	p: Gain Limit
CAM_BrightPosInq	8x 09 04 4D FF	y0 50 00 00 0p 0q FF	pq: Bright Position
CAM_ExpCompModeInq	8x 09 04 3E FF	y0 50 02 FF	On
		y0 50 03 FF	Off
CAM_ExpCompPosInq	8x 09 04 4E FF	y0 50 00 00 0p 0q FF	pq: ExpComp Position
CAM_BackLightModeInq	8x 09 04 33 FF	y0 50 02 FF	On
		y0 50 03 FF	Off
CAM_SpotAEModeInq	8x 09 04 59 FF	y0 50 02 FF	On
		y0 50 03 FF	Off
CAM_SpotAEPosInq	8x 09 04 29 FF	y0 50 0p 0q 0r 0s FF	pq: X position rs: Y position
CAM_AE_ResponseInq	8x 09 04 5D FF	y0 50 pp FF	pp: 01 to 0x20
CAM_WDModeInq	8x 09 04 3D FF	y0 50 02 FF	On Wide-D
		y0 50 03 FF	Off
		y0 50 06 FF	VE On
CAM_WDParameterInq	8x 09 04 2D FF	y0 50 0p 0p 0q 0r 0s 0t 0u 00 00 FF	q: Display brightness level (0: Dark to 6: Bright) r: Brightness compensation selection (0: Very dark, 1: Dark, 2: Standard, 3: Bright) s: Compensation level (0: Low, 1: Mid, 2: High) tu: 0

Inquiry Command

Inquiry Command	Command Packet	Inquiry Packet	Comments
CAM_DefogInq	8x 09 04 37 FF	y0 50 02 0p FF y0 50 03 00 FF	On p: Defog level (0: auto, 1: low, 2: mid, 3: high) Off
CAM_ApertureInq	8x 09 04 42 FF	y0 50 00 00 0p 0q FF	pq: Aperture Gain
CAM_HRModelInq	8x 09 04 52 FF	y0 50 02 FF y0 50 03 FF	On (Hi-Resolution) Off
CAM_NRModelInq	8x 09 04 53 FF	y0 50 0p FF	Noise Reduction p: (0: OFF, level 1 to 3)
CAM_GammaInq	8x 09 04 5B FF	y0 50 0p FF	Gamma p: 0 to 4
CAM_HighSensitivityInq	8x 09 04 5E FF	y0 50 02 FF y0 50 03 FF	On Off
LR_ReverseModelInq	8x 09 04 61 FF	y0 50 02 FF y0 50 03 FF	On Off
FreezeModelInq	8x 09 04 62 FF	y0 50 02 FF y0 50 03 FF	On Off
PictureEffectModelInq	8x 09 04 63 FF	y0 50 00 FF y0 50 02 FF y0 50 04 FF	Off Neg.Art B&W
PictureFlipModelInq	8x 09 04 66 FF	y0 50 02 FF y0 50 03 FF	On Off
ICRModelInq	8x 09 04 01 FF	y0 50 02 FF y0 50 03 FF	On Off
AutoICRModelInq	8x 09 04 51 FF	y0 50 02 FF y0 50 03 FF	On Off
AutoICRThresholdInq	8x 09 04 21 FF	y0 50 00 00 0p 0q FF	pq: ICR ON - OFF Threshold Level
AutoICRAAlarmReplyInq	8x 09 04 31 FF	y0 50 02 FF y0 50 03 FF	On Off
MemoryInq	8x 09 04 3F FF	y0 50 pp FF	pp: Memory number recalled last
MemSaveInq	8x 09 04 23 0X FF	y0 50 0p 0p 0q 0q FF	X: 00 to 07 (Address) ppqq: 0x0000 to 0xFFFF (Data)
DisplayModelInq	8x 09 04 15 FF (8x 09 06 06 FF)	y0 50 02 FF y0 50 03 FF	On Off

Inquiry Command

Inquiry Command	Command Packet	Inquiry Packet	Comments
StabilizerModelInq	8x 09 04 34 FF	y0 50 02 FF	On
		y0 50 03 FF	Off
		y0 50 00 FF	Hold
TitleDisplayModelInq	8x 09 04 74 FF (8x 09 06 06 FF)	y0 50 02 FF	On
		y0 50 03 FF	Off
MuteModelInq	8x 09 04 75 FF	y0 50 02 FF	On
		y0 50 03 FF	Off
PrivacyDisplayInq	8x 09 04 77 FF	y0 50 pp pp pp pp FF	pp pp pp pp: Mask Display (0: OFF 1: ON)
PrivacyPanTiltInq	8x 09 04 79 FF	y0 50 0p 0p 0p 0q 0q 0q FF	ppp: Pan qqq: Tilt
PrivacyPTZInq	8x 09 04 7B mm FF	y0 50 0p 0p 0p 0q 0q 0q 0r 0r 0r 0r FF	mm: Mask Settings ppp: Pan qqq: Tilt rrr: Zoom
PrivacyMonitorInq	8x 09 04 6F FF	y0 50 pp pp pp pp FF	pp pp pp pp: Mask is displayed now.
CAM_KeyLockInq	8x 09 04 17 FF	y0 50 00 FF	Off
		y0 50 02 FF	On
CAM_IDInq	8x 09 04 22 FF	y0 50 0p 0q 0r 0s FF	pqrs: Camera ID
CAM_VersionInq	8x 09 00 02 FF	y0 50 gg gg mn pq rs tu vw FF	gggg: Vender ID (00bc) mnpq: Model Code rstu: ROM version vw: Socket Number (=02)
AlarmInq	8x 09 04 6B FF	y0 50 02 FF	On
		y0 50 03 FF	Off
MDModelInq	8x 09 04 1B FF	y0 50 02 FF	On
		y0 50 03 FF	Off

Inquiry Command

Inquiry Command	Command Packet	Inquiry Packet	Comments
MDFunctionInq	8x 09 04 1C FF	y0 50 0m 0n 0p 0q 0r 0s FF	m: Display mode 0-Off 1-On n: Detection Frame Set bit0-Frame0 bit1-Frame1 bit2-Frame2 pq: Threshold Level (0 to 0x14) <i>rs: Interval Time set (0 to 0xF)</i>
MDWindowInq	8x 09 04 1D 0m FF	y0 50 pp qq rr ss FF	m: Select Detection Frame (0 1 2 3) pp: Start Horizontal Position (00 to 0x3C) qq: Start Vertical Position (00 to 0x28) rr: Stop Horizontal Position (01 to 0x3C) ss: Stop Vertical Position (01 to 0x28)
ContinuousZoomPos	8x 09 04 69 FF	y0 50 02 FF	On
ReplyModelInq		y0 50 03 FF	Off
ReplyIntervalTimeInq	8x 09 04 6A FF	y0 50 00 00 0p 0p FF	pp: Interval Time [VD timing]
ColorEnhanceInq	8x 09 04 20 FF	y0 50 mm nn pp qq rr FF	<i>mm: First byte from the top threshold value</i> <i>nn: Second byte from the top threshold value</i> <i>pp: Third byte from the top threshold value</i> <i>qq: Color specification for high-intensity</i> <i>rr: Color specification for low-intensity</i> 0: Yellow 1:Cyan 2:Green 3:White 4: Magenta 5:Red 6:Blue 7:Black 8:Gray
	8x 09 04 50 FF	y0 50 02 FF	On
		y0 50 03 FF	Off
ChromaSuppressInq	8x 09 04 5F FF	y0 50 pp FF	pp: Chroma Suppress setting level
ColorGainInq	8x 09 04 49 FF	y0 50 00 00 00 0p FF	p: Color Gain setting 0h (60%) to Eh (200%)
ColorHueInq	8x 09 04 4F FF	y0 50 00 00 00 0p FF	p: Color Hue setting 0h (? 14 degrees) ~ Eh (+ 14 degrees)
CAM_TempInq	8x 09 04 68 FF	y0 50 00 00 0p 0q FF	<i>pq : Current Temperature</i> 0(0°C) ~ 0x7F(127 °C)
CAM_HLCInq	8x 09 04 14 FF	y0 50 0p 0q FF	p: HLC level (0: OFF, 1: ON) q: HLC mask level (0 to F: from low to high level)
CAM_Menu	8x 09 06 06 FF	y0 50 0p FF	p: 2-ON 3-OFF
FocusStatusInq	8x 09 04 08 FF	y0 50 02 FF	Focus executing
		y0 50 03 FF	Focus stopped

Inquiry Command : Register

Inquiry Command	Command Packet	Inquiry Packet	Comments
BaudRate	8x 09 04 24 00 FF	y0 50 00 0p FF	p: 0-9600 1-19200 2-38400 3-115200
Monitoring Mode	8x 09 04 24 72 FF	y0 50 0p 0p FF	pp: 1-1080i@59.94 (specific model) 2--1080i@60 3- 4-1080i@50 5- 6-1080p@29.97 (specific model) 7-1080p@30 8-1080p@25 9-720p@59.94 (specific model) A-720p@60 B- C-720p@50 D- E-720p@29.97(specific model) F-720p@30 10- 11-720p@25 12- 13-1080p@59.94 (specific model) 14-1080p@50 15-1080p@60
Output enable	8x 09 04 24 73 FF	y0 50 00 0p FF	p: 2-LVDS output On 4-SDI output On
LVDS Mode	8x 09 04 24 74 FF	y0 50 00 0p FF	p: 0-LVDS Single output 1-Dual output
Wide limit	8x 09 04 24 50 FF	y0 50 0p 0p FF	pp: 0~FF refer Table
Tele limit	8x 09 04 24 51 FF	y0 50 0p 0p FF	pp: 0~FF refer Table
E-Zoom Max	8x 09 04 24 52 FF	y0 50 0p 0p FF	pp: Max D-zoom ratio = 256/ (256-pp)
Stable Zoom	8x 09 04 24 53 FF	y0 50 00 0p FF	p: 0-OFF 1-ON
Focus Trace	8x 09 04 24 54 FF	y0 50 00 0p FF	p: 0-OFF 1-ON
Focus Offset	8x 09 04 24 55 FF	y0 50 00 pp FF	pp: 0-FF
Auto Slow Shutter	8x 09 04 24 59 FF	y0 50 00 0p FF	p: 1-1/30 2-1/15 3-1/8 4-1/4 5-1/2 6-1/1

Limit			
Shading	8x 09 04 24 1B FF	y0 50 00 0p FF	p: 0-OFF 1-ON
D/N Margin	8x 09 04 24 28 FF	y0 50 0p 0p FF	pp: Margin 0~20
D/N DWell Time	8x 09 04 24 29 FF	y0 50 0p 0p FF	pp: DWELL time 1~20
Night Burst on	8x 09 04 24 30 FF	y0 50 00 0p FF	p: 0-OFF 1-ON
E-Clipse On	8x 09 04 24 2D FF	y0 50 00 0p FF	p: 0-OFF 1-ON
E-Clipse Level	8x 09 04 24 2E FF	y0 50 0p 0p FF	pp: HighLight Level 0~20
E-Clipse Color	8x 09 04 24 2F FF	y0 50 00 0p FF	p: MaskColor 0:WHT 1:YEL 2:CYN 3:GRN 4:MAG 5:RED 6:BLU 7:BLK
PrvMaskTrans	8x 09 04 24 3A FF	y0 50 00 0p FF	p: Privacy Mask Transparency 0-4
Flickerless	8x 09 04 24 3D FF	y0 50 00 0p FF	p: 0-OFF 1-ON
AE_InOutdoor	8x 09 04 24 4B FF	y0 50 00 0p FF	p: 0-AE Indoor Mode 1-AE Outdoor Mode
Contrast	8x 09 04 24 76 FF	y0 50 0p 0p FF	pp: 0~0x40(64)
EdgeColorSuppress	8x 09 04 24 80 FF	y0 50 0p 0q FF	p:0-F (edge color suppression -WDR mode) q:0-F (edge color suppression -Normal)
Focus Near Limit	8x 09 04 24 5F FF	y0 50 00 0p FF	p: Near Limit 0-30Cm, 1-1M, 2-1.5M, 3-2M, 4-3M, 5-5M, 6-10M
Focus Far Limit	8x 09 04 24 60 FF	y0 50 00 0p FF	p: Far Limit 0-2M, 1-3M, 2-5M, 3-10M, 4-Infinity
NightSatLevel	8x 09 04 24 7C FF	y0 50 00 0p FF	p: 0-Off 1(Low) ~ 20(High)

Block Inquiry Command

Inquiry Command	Command Packet	Inquiry Packet	Comments
Lens Control System Inquiry	8x 09 7E 7E 00 FF	y0 50 0p 0p 0p 0p 0q 0q 0r 0r 0r 0r 00 hh 0m FF	pppp: Zoom position qq: Near limit 0-30Cm, 1-1M, 2-1.5M, 3-2M, 4-3M, 5-5M, 6-10M rrrr: Focus position hh: [5]DzoomMode 0-combine 1-seperate [4:3] 0-Nor 1-Interval 2-ztrg [2]AF sensitivity 0-slow 1-Nor [1]Dzoom 0-off 1-on [0]FocusMode 0-Manual 1-Auto m: [3]Low contrast detection 0-no 1-yes [2]Camera memory recall 0-stopped 1-executing [1]Focus command 0-stopped 1-executing [0]Zoom command 0-stopped 1-executing
			pp: Rgain qq: Bgain r: WB mode s: Aperture gain t: Exposue Mode hh: [5]High resolution 0-off 1-on [4]Wide-D 0-off 1-other than off [3]Spot AE 0-off 1-on [2]Back Light 0-off 1-on [1]Exposure comp. 0-off 1-on [0]slow shutter 0-Manual 1-Auto mm: Shutter position nn: Iris position u: Gain position vv: Bright position w: Exposure Comp. position

Block Inquiry Command

Inquiry Command	Command Packet	Inquiry Packet	Comments
	8x 09 7E 7E 02 FF	y0 50 0p qq rr 0s 00 00 0t 0t 0t 0t hh 00 00 FF	p: [3]Auto ICR alarm 0-off 1-on [2]Auto ICR 0-off 1-on [1]0 [0]power 0-off 1-on qq: [6]Stabilizer 0-off 1-on [5]Stabilizer Hold 0-off 1-Hold [4]ICR 0-off 1-on [3]Freeze 0-off 1-on [2]LR Reverse 0-off 1-on rr: [5]Privacy zone 0-off 1-on [4]Mute 0-off 1-on [3]Title display 0-off 1-on [2]Display 0-off 1-on s: Picture Effect Mode [2]B&W 0-off1-on [1]Neg.Art 0-off1-on tttt: Cam ID hh: [4]Memory 0-not provided 1-provided [3]0 [2]ICR 0-not provided 1-provided [1]Stabilizer 0-Not provided 1-Provided [0]0-1/60,1/30 1-1/50,1/25

Block Inquiry Command

Inquiry Command	Command Packet	Inquiry Packet	Comments
	8x 09 7E 7E 03 FF	y0 50 0p 0p 0q 0q 0r 0r 0s 0t 0u vv hh mm nn FF	<p>pp: Dzoom position</p> <p>qq: AF activation time</p> <p>rr: AF Interval time</p> <p>s: SpotAE position X</p> <p>t: SpotAE position Y</p> <p>u: [2]MD 0-off 1-on [1]Alarm 0-off 1-on [0]flip 0-off 1-on</p> <p>vv: [6:3]color gain</p> <p>[2]Advanced privacy 0-not provided</p> <p>[1]Alarm 1- provided</p> <p>[0]flip 1- provided</p> <p>hh: AE response</p> <p>mm: [6:4]Gamma</p> <p>[3]High Sensitivity mode 0-off 1-on</p> <p>[2:0]NR level</p> <p>nn: [6:4]Chroma suppression</p> <p>[3:0]Gain limit</p>
	8x 09 7E 7E 04 FF	y0 50 0p 0q 0r 0s 0t 0u 0v 00 00 00 00 00 00 FF	<p>p: WideD mode 0-off 1-on</p> <p>2-VE On</p> <p>r: Display brightness level setting</p> <p>0: Dark to 6: Bright</p> <p>s: Brightness compensation selection</p> <p>0: Very dark 1: Dark 2: Standard 3: Bright</p> <p>t: Compensation level 0: Low 1: Mid 2: High</p> <p>u: [0]Defog 0-off 1-on</p> <p>v: [1:0] Defog Level 0:auto 1:low 2:mid 3:high</p>
	8x 09 7E 7E 05 FF	y0 50 0p 00 00 00 00 00 00 00 00 00 00 00 FF	<p>p: Color Hue</p>

TABLE.**Shutter Speed**

Value	NTSC	PAL
15	1/10000 (1/20000)	1/10000 (1/20000)
14	1/6000 (1/12000)	1/6000 (1/12000)
13	1/4000 (1/8000)	1/3500 (1/7000)
12	1/3000 (1/6000)	1/2500 (1/5000)
11	1/2000 (1/4000)	1/1750 (1/3500)
10	1/1500 (1/3000)	1/1250 (1/2500)
0F	1/1000 (1/2000)	1/1000 (1/2000)
0E	1/725 (1/1450)	1/600 (1/1200)
0D	1/500 (1/1000)	1/425 (1/850)
0C	1/350 (1/700)	1/300 (1/600)
0B	1/250 (1/500)	1/215 (1/430)
0A	1/180 (1/360)	1/150 (1/300)
09	1/125 (1/250)	1/120 (1/240)
08	1/100 (1/200)	1/100 (1/200)
07	1/90 (1/180)	1/75 (1/150)
06	1/60 (1/120)	1/50 (1/100)
05	1/30 (1/60)	1/25 (1/50)
04	1/15 (1/30)	1/12 (1/25)
03	1/8 (1/15)	1/6 (1/12)
02	1/4 (1/8)	1/3 (1/6)
01	1/2 (1/4)	1/2 (1/3)
00	1/1 (1/2)	1/1 (1/2)

IRIS

Value	F no.
11	F1.6
10	F2
0F	F2.4
0E	F2.8
0D	F3.4
0C	F4
0B	F4.8
0A	F5.6
09	F6.8
08	F8
07	F9.6
06	F11
05	F14
00	CLOSE

Gain

Value	dB	
0F	+28 dB	
0E	+26 dB	
0D	+24 dB	
0C	+22 dB	
0B	+20 dB	
0A	+18 dB	
09	+16 dB	
08	+14 dB	
07	+12 dB	
06	+10 dB	
05	+8 dB	
04	+6 dB	
03	+4 dB	
02	+2 dB	
01	0 dB	
00	-3 dB	

Gain Limit

Value	dB	
0F	+28 dB	
0E	+26 dB	
0D	+24 dB	
0C	+22 dB	
0B	+20 dB	
0A	+18 dB	
09	+16 dB	
08	+14 dB	
07	+12 dB	
06	+10 dB	
05	+8 dB	
04	+6 dB	

Brightness

Value	IRIS	GAIN
1F	F1.6	+28 dB
1E	F1.6	+26 dB
1D	F1.6	+24 dB
1C	F1.6	+22 dB
1B	F1.6	+20 dB
1A	F1.6	+18 dB
19	F1.6	+16 dB
18	F1.6	+14 dB
17	F1.6	+12 dB
16	F1.6	+10 dB
15	F1.6	+8 dB
14	F1.6	+6 dB
13	F1.6	+4 dB
12	F1.6	+2 dB
11	F1.6	0 dB
10	F2	0 dB
0F	F2.4	0 dB
0E	F2.8	0 dB
0D	F3.4	0 dB
0C	F4	0 dB
0B	F4.8	0 dB
0A	F5.6	0 dB
09	F6.8	0 dB
08	F8	0 dB
07	F9.6	0 dB
06	F11	0 dB
05	F14	0 dB
00	CLOSE	0 dB

Zoom Ratio	Zoom Ratio	Position Data
Optical Zoom	×1	0000
	×2	1851
	×3	22BE
	×4	28F6
	×5	2D45
	×6	3086
	×7	3320
	×8	3549
	×9	371E
	×10	38B3
	×11	3A12
	×12	3B42
	×13	3C47
	×14	3D25
	×15	3DDF
	×16	3E7B
	×17	3EFB
	×18	3F64
	×19	3FBA
	×20	4000
Digital Zoom	×1	4000
	×2	6000
	×3	6A80
	×4	7000
	×5	7300
	×6	7540
	×7	76C0
	×8	7800
	×9	78C0
	×10	7980
	×11	7A00
	×12	7AC0

Limit Setting Value	Wide Limit	Tele Limit
00	x1.0	x20
10	x1.04	x19
20	x1.07	x18
30	x1.11	x17
40	x1.16	x16
50	x1.20	x15
60	x1.25	x14
70	x1.30	x13
80	x1.36	x12
90	x1.42	x11
A0	x1.48	x10
B0	x1.54	x9.0
C0	x1.61	x8.0
D0	x1.68	x7.0
E0	x1.77	x6.35
F0	x1.87	x6.0