

2.0um High Power Chirped FBG for Fiber Laser

Product Description:

GKER high-quality 2.0um fiber grating reflectors (also called Fiber Laser cavity mirrors) are written in specialty double clad optical fiber with optimized chirped Fiber Bragg Grating (FBG) writing technology. They are specially designed for 2.0um high power continuous and pulsed fiber

lasers, suitable for single-mode fiber to the large mode field (LMA) fiber, the pump power handling capacity can reach more than 200W.



GKER can provide various bandwidths and accurately matched high and low reflectivity gratings for different applications. They are offered in heat dissipative package or recoated only.

Features:

- Extremely Low Temperature Slope
- High Conversion Efficiency
- High Power Handling
- Outstanding Reliability
- Wide Variety of Fiber Types

Applications:

- High Power Fiber Laser
- Pulsed Fiber Laser

Specifications:

Parameter	Unit	Specification	
Typical Central Wavelength ¹	nm	1908, 1940, 1980	
Tolerance on Central Wavelength	nm	1	
Type of Reflector		HR	LR
Peak Reflectivity ²	%	>99.5	10±2
FWHM ² (-3dB)	nm	2±0.2	1±0.1
Side Mode Suppression Ratio	dB	20	10
Wavelength Mismatch (LR to HR)	m	0.2	
Input/output Fiber Length	m	1	
Package Type		Recoated or High Power Metal Housing	

Notes:

1. Other central wavelength available on request.
2. Other bandwidth and reflectivity available on request.

Fiber Types:

Fiber Core/Cladding Diameter(um)	Handling Power of Pump (W)		Package	
	50	200	Recoated Only	Heat Dissipation Package
10/130	√		√	√
25/250		√	√	√
25/400		√	√	√

Notes: Other fiber types available on request

Package Dimensions:

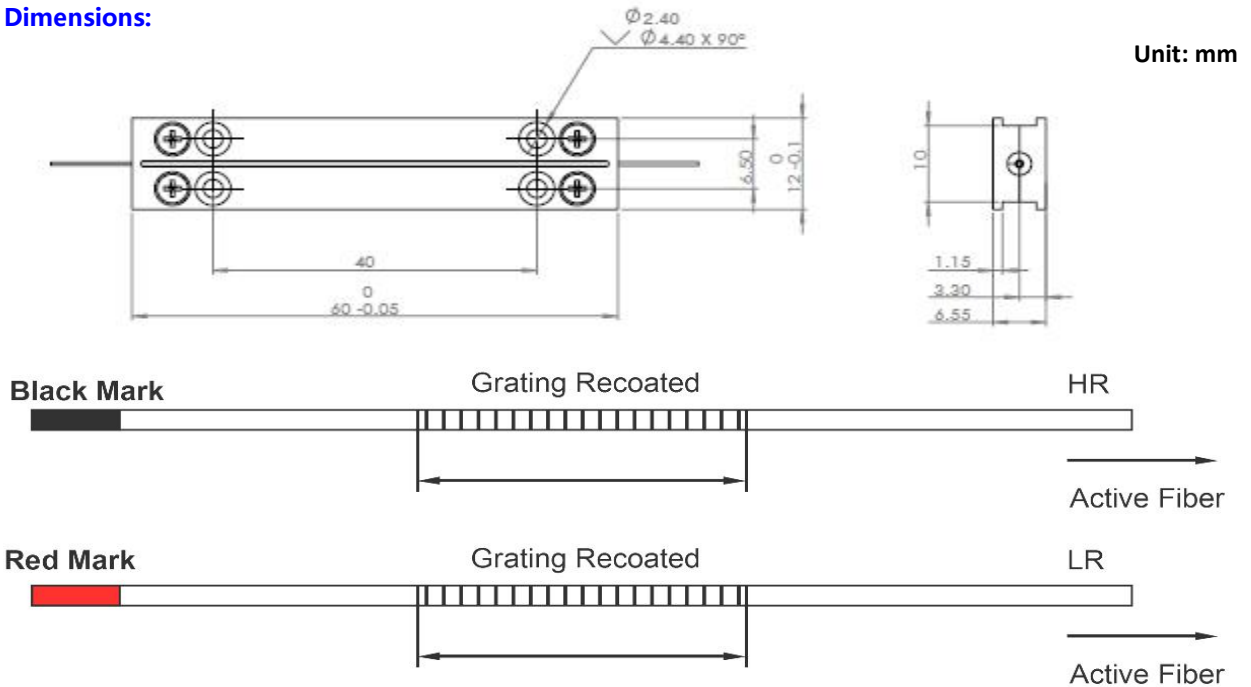

Ordering Information:

F-1111-2-333-44-5-66

- 1111: Fiber Type
 - 1013: 10/130um NA=0.15/0.46
 - 2525: 25/250um NA=0.11/0.46
 - 2540: 25/400um NA=0.11/0.46
- 2: Grating Type
 - H: High Reflector
 - L: Low Reflector
- 333: Central Wavelength in nm
 - 908: 1908nm
- 44: Bandwidth in nm
 - 02: 2nm
- 5: Package
 - M: Metal Housing
 - R: Recoated
- 66: Reflectivity in %
 - 99: 99%
 - 10: 10%