



Item No.: FC808DL100

Item Name: 100W 808nm Fiber Coupled Diode Laser

Optical	Typical Value
Center Wavelength λ	808nm \pm 5nm
Output Power	100W
Working Mode	CW

Fiber	
Fiber Core	200um
Fiber Numerical Aperture	0.22NA
Fiber Length	1.5m
Fiber Connector	BARE

Electrical	
Threshold Current I_{th}	1.5A
Operating Current I_{op}	12A
Operating Voltage V_{op}	23V

Thermal	
Test Temperature	25°C
Storage Temperature	-20~55°C
Wavelength Temperature Coefficient	0.35nm/°C

Package Drawing

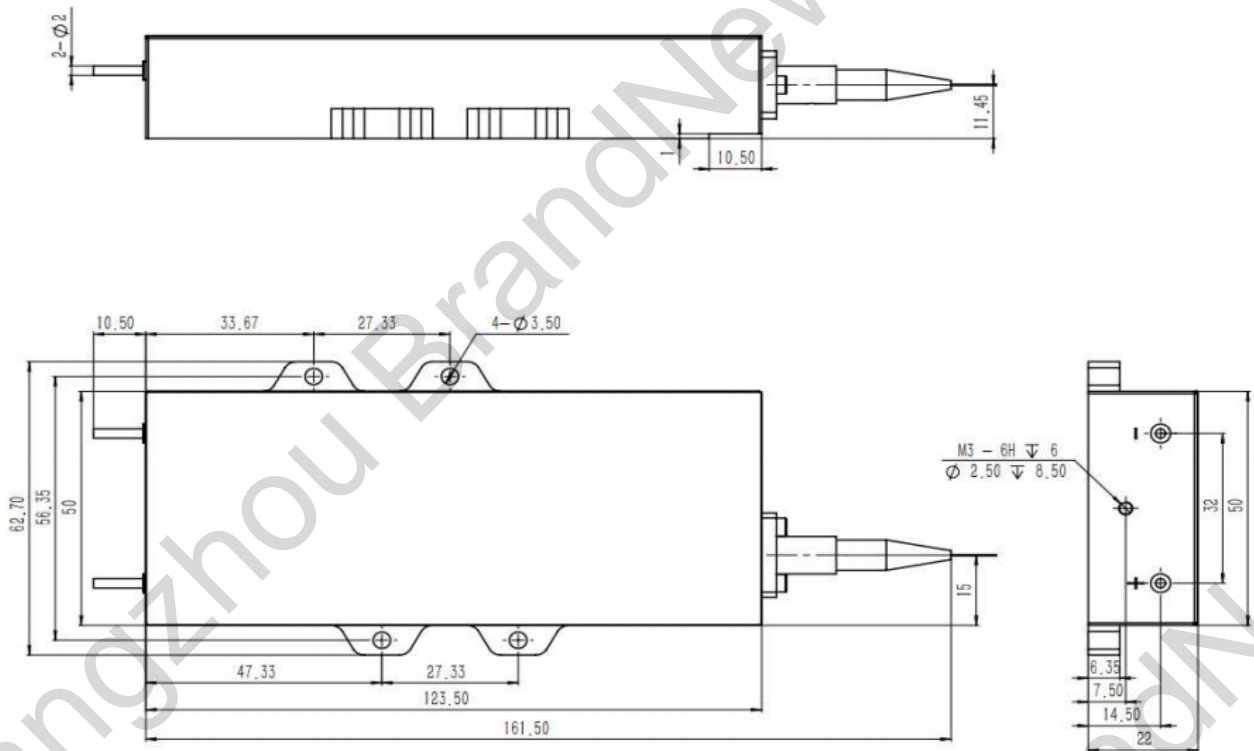

Subject to change without notice



VISIBLE AND INVISIBLE LASER RADIATION.
 AVOID EYE OR SKIN EXPOSURE TO
 DIRECT OR SCATTERED RADIATION!
 CLASS 4 LASER PRODUCT
 IEC 825-1